



Microprocessor Controlled
IGBT Drive
Inverter Motor Speed Regulator
Operating Manual

| | | |
|-----------|------|-------------------------|
| EV Series | 110V | 0.2~0.75KW (0.2~1HP) |
| | 220V | 0.2~2.2KW (0.2~3HP) |
| | 440V | 0.75~2.2KW (1~3HP) |



TECO Electric & Machinery Co., Ltd.

7F, No.49, Wu Kong 6 Rd. Wu-Ku Industrial Park,

Taipei County 248, TAIWAN

Tel : +886-2-8990-1111

Fax : +886-2-2299-1497

<http://www.teco.com.tw>

Distributor

4KA72X016T01 Ver.02 2005.08

This manual may be modified when necessary because of improvement of the product, modification, or changes in specifications, This manual is subject to change without notice.

Quick Start Guide

This guide is to assist in installing and running the inverter to verify that the drive and motor are working properly. Starting, stopping and speed control will be from the keypad. If your application requires external control or special system programming, consult the 7300EV Instruction Manual supplied with your inverter.

Step 1 Before starting the inverter

Please refer to chapter one (Preface) and chapter two (Safety Precautions) of the 7300EV Instruction Manual. Verify drive was installed in accordance with the procedures as described in chapter three (Environment description and installation). If you feel this was abnormal, do not start the drive until qualified personnel have corrected the situation. (Failure to do so could result in serious injury.)

- Check inverter and motor nameplates to determine that they have the same HP and voltage ratings. (Ensure that full load motor amps do not exceed that of the inverter.)
- Remove the terminal cover to expose the motor and power terminals.
 - a. Verify that AC power is wired to L1(L), L2, and L3(N) .
 - b. Verify that Motor leads are connected to T1, T2, and T3 .
 - c. IF brake module is necessary, please connect terminal voltage of the braking unit to P and N of the inverter.

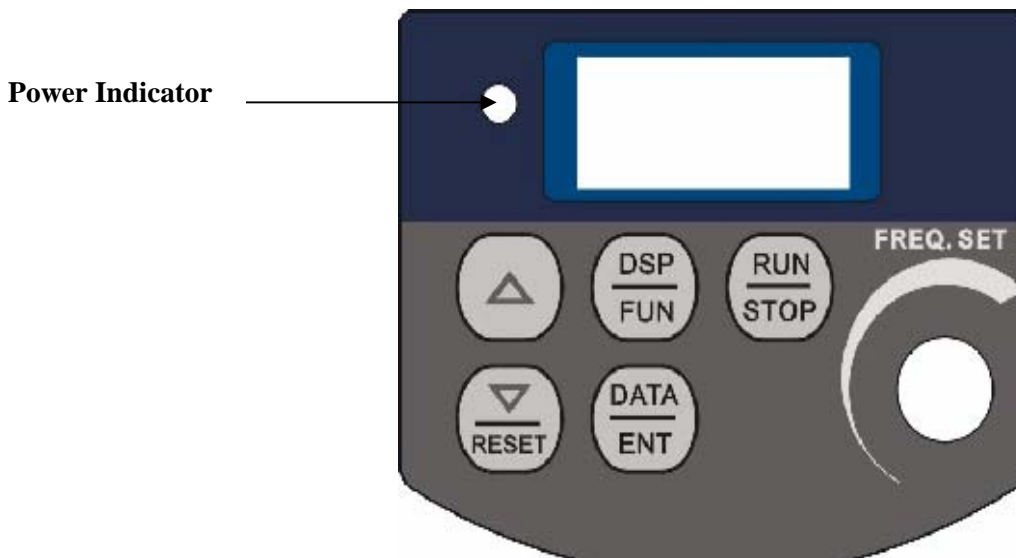

Step2 Apply power to the drive.

Apply AC power to the drive and observe operator. Three 7-segment display should show power voltage for 3~5 seconds and then show Frequency Command, factory sets 5.00. (Frequency Command of 7-segment display should be flashed all the time.)

Step3 Check motor rotation without load.

- Press RUN Key. 7-segment Display will indicates 00.0to 05.0. Such value is the frequency output value.
- Check the operation direction of the motor.
IF the direction of the motor is incorrect:
Press STOP Key, turn off the AC power supply. After Power indicator LED is off, change over theT1 and T2.
Supply the power again, then check the motor direction.
- Press STOP key.

Step4 Check full speed at 50Hz/60Hz

- Change the frequency with ▲,▼ arrow mark , please press DATA/ENTER after setting frequency.
- Set frequency to 50Hz/60Hz according to the above regulations.
- Press RUN Key, inspect the motor operation as motor accelerates to full load.
- Press STOP Key, inspect the motor operation as motor deceleration.

Step5 Other settings

As for other function, please refer to 7300EV user manual.

| | |
|--------------------------------------|---------|
| Set acceleration time | P. 4-9 |
| Set deceleration time | P. 4-9 |
| Set upper frequency limit | P. 4-12 |
| Set lower frequency limit | P. 4-12 |
| Set motor rated current | P. 4-30 |
| Set control mode (Vector, V/F) | P. 4-26 |

7300EV user manual

Content

| | |
|---|-------------|
| Tutorial | i |
| Chapter 0 Preface | 0-1 |
| 0.1 Preface | 0-1 |
| 0.2 Product inspection | 0-1 |
| Chapter 1 Safety precautions..... | 1-1 |
| 1.1 Operation precautions..... | 1-1 |
| 1.1.1 Before Power up..... | 1-1 |
| 1.1.2 During Power up..... | 1-2 |
| 1.1.3 Before operation | 1-2 |
| 1.1.4 Leakage current announce | 1-2 |
| 1.1.5 During operation..... | 1-3 |
| 1.1.6 Useable environment | 1-3 |
| Chapter 2 Model definition | 2-1 |
| Chapter 3 Environment description and installation..... | 3-1 |
| 3.1 Environment | 3-1 |
| 3.2 Environment precautions..... | 3-6 |
| 3.3 Wiring Rules..... | 3-7 |
| 3.3.1 Notice for wiring..... | 3-7 |
| 3.3.2 Suitable MC, MCCB, Fuse and wire specification | 3-9 |
| 3.3.3 Precautions for peripheral applications..... | 3-10 |
| 3.4 Specification | 3-13 |
| 3.4.1 Product individual specification..... | 3-13 |
| 3.4.2 General specifications..... | 3-14 |
| 3.5 7300EV wiring diagram..... | 3-16 |
| 3.6 Description of inverter terminal | 3-17 |
| 3.7 Dimension | 3-20 |
| 3.8 Installation and design consideration..... | 3-23 |

| | |
|---|-------------------|
| Chapter 4 Programming instructions & Parameter list..... | 4-1 |
| 4.1 Keypad description..... | 4-1 |
| 4.1.1 Keypad display and operation instruction..... | 4-1 |
| 4.1.2 Operation instruction of the keypad..... | 4-1 |
| 4.2 Parameter function list..... | 4-3 |
| 4.3 Parameter function description..... | 4-9 |
| | |
| Chapter 5 Trouble shooting and maintenance..... | 5-1 |
| 5.1 Trouble indication and remedy..... | 5-1 |
| 5.1.1 Fault/Error display and Diagnostics..... | 5-1 |
| 5.1.2 Set up& Interface Errors | 5-4 |
| 5.1.3 Keypad operation error description..... | 5-5 |
| 5.2 General functional troubleshooting..... | 5-6 |
| 5.3 Troubleshooting flowcharts 7300EV Series..... | 5-7 |
| 5.4 Routine and periodic checks..... | 5-13 |
| 5.5 Maintenance and inspection..... | 5-14 |
| | |
| Chapter 6 peripherals components..... | 6-1 |
| 6.1 Input side AC reactor..... | 6-1 |
| 6.2 EMC filter..... | 6-1 |
| 6.3 Option card..... | 6-6 |
| 6.3.1 RS-485 option card..... | 6-6 |
| 6.3.2 RS-232 option card..... | 6-7 |
| 6.3.3 Program copy option card..... | 6-8 |
| 6.3.4 Remote keypad | 6-9 |
| 6.3.5 2 IN/1OUT Card | 6-10 |
| | |
| Appendix 1 7300EV inverter parameter setting list..... | Appendix 1 |

Chapter 0 Preface

0.1 Preface

To extend the performance of the product and ensure your safety, read this manual thoroughly before using the inverter. Should there be any problem in using the product and can not be solved with the information provided in the manual, contact your nearest TECO distributor or our sales representatives who will be willing to help you. Please keep using TECO's products in the future.

Precautions

The inverter is an electrical electronic product. For your safety, there are symbols such as “Danger”, “Caution” in this manual to remind you to pay attention to safety instructions on carrying, installing, operating, and checking the inverter. Be sure to follow the instructions for highest safety.



Danger

Indicates a potential hazard that causes death or serious personal injury if misused



Caution

Indicates that the inverter or the mechanical system might be damaged if misused



Danger

- Do not touch any circuit boards or parts if the charging indicator is still lit after turning the power off.
- Do not connect any wires when the inverter is powered. Do not check parts and signals on circuit boards when the inverter is in operation.
- Do not disassemble the inverter and modify internal wires, circuits and parts.
- Ground the ground terminal of the inverter properly, for 200V class ground to 100 Ω or below, 400v class ground to 10Ω or below.



Caution

- Do not perform a voltage test on parts inside the inverter. High voltage will easily destroy these semiconductor parts.
- Do not connect T1 (U), T2 (V), and T3 (W) terminals of the inverter to AC power source.
- CMOS ICs on the inverter's main board are sensitive to static electricity. Do not touch the main board.

0.2 Products Inspection

TECO's inverters are all passed the function test before delivery. Please check the followings when you receive and unpack the inverter:

- The model and capacity of the inverter is the same as those specified on your order.
- Is there any damage caused by transportation. If so, do not apply the power.
Contact TECO's sales representatives if any of the above problems happened.

Chapter 1 Safety Precautions

1.1 Operation Precautions

1.1.1 Before Power Up



Caution

The line voltage applied must comply with the inverter's specified input voltage.



Danger

Make sure the main circuit connections are correct. L1(L), L2, and L3(N) are power-input terminals and must not be confused with T1, T2 and T3. Otherwise, the inverter might be damaged.



Caution

- To avoid the front cover from disengaging, do not pull the cover when carrying the inverter for which the heat sink should be handled. Accident falling down will damage the inverter or injure personnel and should be avoided.
- To avoid fire, do not install the inverter on a flammable object. Intall it on nonflammable objects such as metal.
- If several inverters are placed in the same control panel, add extra heat dissipators to keep the temperature below 50°C to avoid overheat or fire.
- When removing or installing the operator, turn the power off first, and operate the operator following the instruction of the diagram to avoid operator error or no display caused by bad contact.

Warning

Our product complies with IEC 61800-3, with built-in Filter in an unrestricted distribution and with use of external filter in restricted distribution. Under some environment which may with electric-magnetic interruption, product should be tested before used.

1.1.2 During Power up

Danger

- The inverter still has control power if the time of power loss is very short. When the power is re-supplied, the inverter operation is controlled by F41.
- The inverter operation is controlled by F04 and C09 and the status of (FWD/REV RUN switch) when power is re-supplied. (and F39 /F40) Power loss ride trough / Auto reset after fault.
 1. When F04=000, the inverter will not auto restart when power is re-supplied.
 2. When F04=001 and operation switches (FWD/REV RUN) is OFF, the inverter will not auto restart when power is re-supplied.
 3. When F04=001 and operation switch ON and C09=000, the inverter will auto restart when power is re-supplied. Please turn OFF the run (start) switch to avoid damage to machine and injury to operator before the power is re-supplied.
- When C09=000 (direct start on power up), please refer to the description and advice of C09 to verify the safety of operator and machine.

1.1.3 Before operation

Caution

Make sure the model and capacity are the same as those set by F00.

1.1.4 Leakage current announce

Warning

Warning ! EV series Build in Filter type its leakage current maybe can over 3.5mA of IEC standard rule. So please certainty connect ground.

Operation with ungrounded supplies:

1. Filtered inverters **CANNOT** be used on ungrounded supplies.
2. Unfiltered inverter can be used on ungrounded supplies , if an output phase is shorted to ground , inverter may trip with OC.(over current trip)

Operation with Residual Current Device(RCD):

1. Filtered inverter with the trip limit of the RCD is 300Ma
2. The neutral of the supply is grounded , the inverter is grounded too.
3. Only one inverter is supplied from each RCD.

1.1.5 During operation



Danger

Do not connect or disconnect the motor while inverter is operating the motor, Otherwise the inverter and the disconnect device will be damaged by the high level of switch off current.



Danger

- To avoid electric shock, do not take the front cover off. during power on.
The motor will restart automatically after stop when auto-restart function is on. In this case, care must be taken while working with the machine.
- Note: The operation of stop switch is different to that of the emergency stop switch. Stop switch has to be activated for it to be effective. Emergency stop has to be de-activated to become effective.



Caution

- Do not touch heat-generating components such as heat sink and brake resistor.
- The inverter can drive the motor running from low speed to high speed. Verify the allowable speed ranges of the motor and the mechanism.
- Note the settings related to the braking unit.
- Do not check signals on circuit PCB while the inverter is running.



Caution

Allow a minimum of 5 minutes power down before attempting to disassemble or checking the components within the drive.

1.1.6 Useable environment



Caution

When the inverter top dust cover has been removed can be used in a non-condensed environment with temperature from -10°C to $+50^{\circ}\text{C}$ and relative humidity of 95%, but the environment should be free from water and metal dust.

Chapter 2 Model description

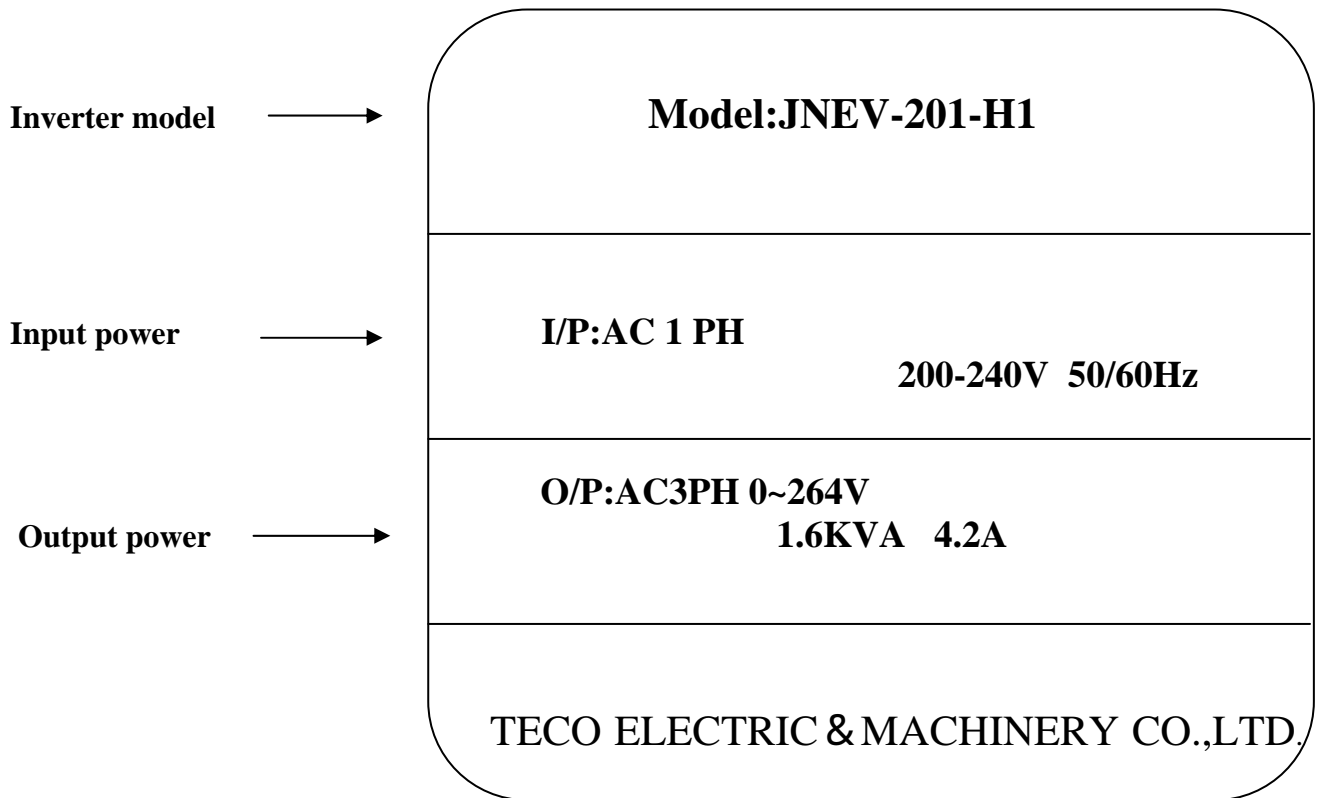

| JNEV - 2 | | P5 | | - H | | 1 | | F | | N4S | |
|-----------------|-----------------|------------------------------|-------------|----------------|----------------|---|--|----------|--|------------|--|
| Series: | Input voltage : | Max suitable motor capacity: | SPEC.: | Power supply : | Noise filter : | Enclosure | | | | | |
| | 1: 110V | P2: 0.25 HP | H: standard | 1:single phase | Blank : none | N4S:IP65 with water and dust proof switch | | | | | |
| | 2: 220V | P5: 0.5 HP | | 3:three phase | F: built-in | | | | | | |
| | 4: 440V | 01: 1.0 HP | | | | N4:IP65 without water and dust proof switch | | | | | |
| | | 02: 2.0 HP | | | | | | | | | |
| | | 03: 3.0 HP | | | | Blank: IP20 | | | | | |

Chapter 3 Environment description and installation

3.1 Environment

The environment will directly affect the proper operation and the life of the inverter, so install the inverter in an environment complies with the following conditions:

- Ambient temperature: $-10 \sim +50$
- Avoid exposure to rain or moisture.
- Avoid smoke and salinity.
- Avoid dust, bats, and small metal pieces.
- Avoid electromagnetic interference (soldering machine, power machine).
- Avoid vibration (punching machine). Add a vibration-proof pad if the situation can not be avoided.
- If several inverters are placed in the same control panel, add extra heat dissipators to keep the temperature below 50°C .
- Avoid direct sunlight.
- Avoid erosive liquid and gas.
- Keep away from radiative and flammable materials.

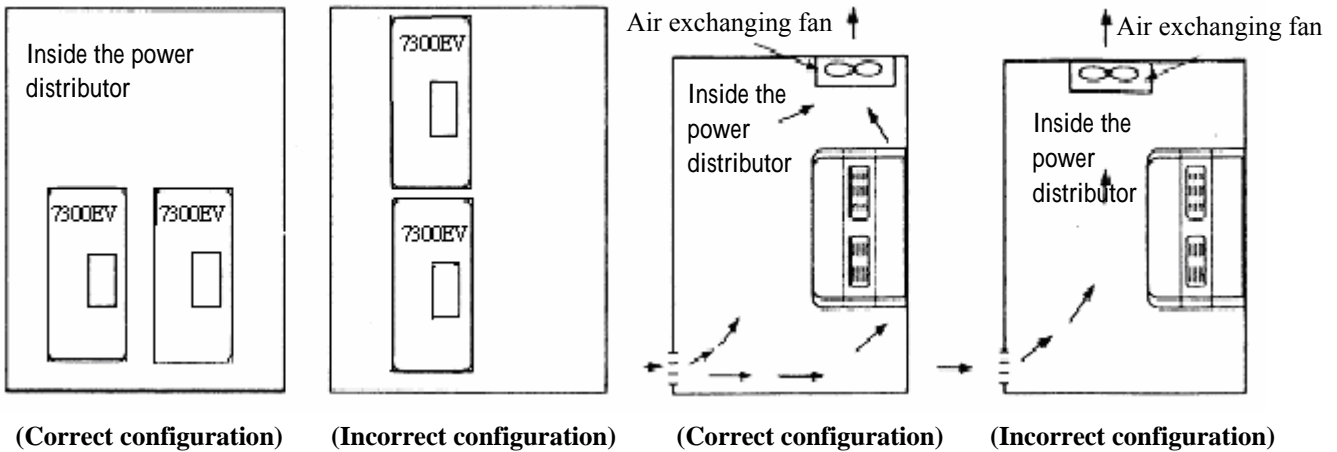

- Place the front side of the inverter onward and top upward to help heat dissipation.

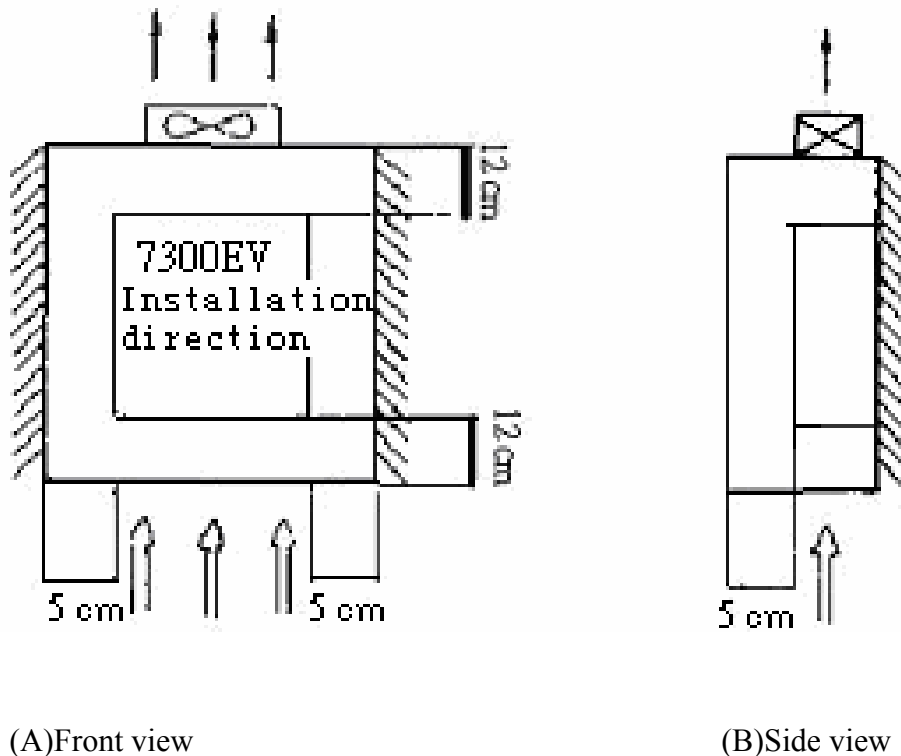

- The chassis of this model has DIN-RAIL device to use with aluminum rail.

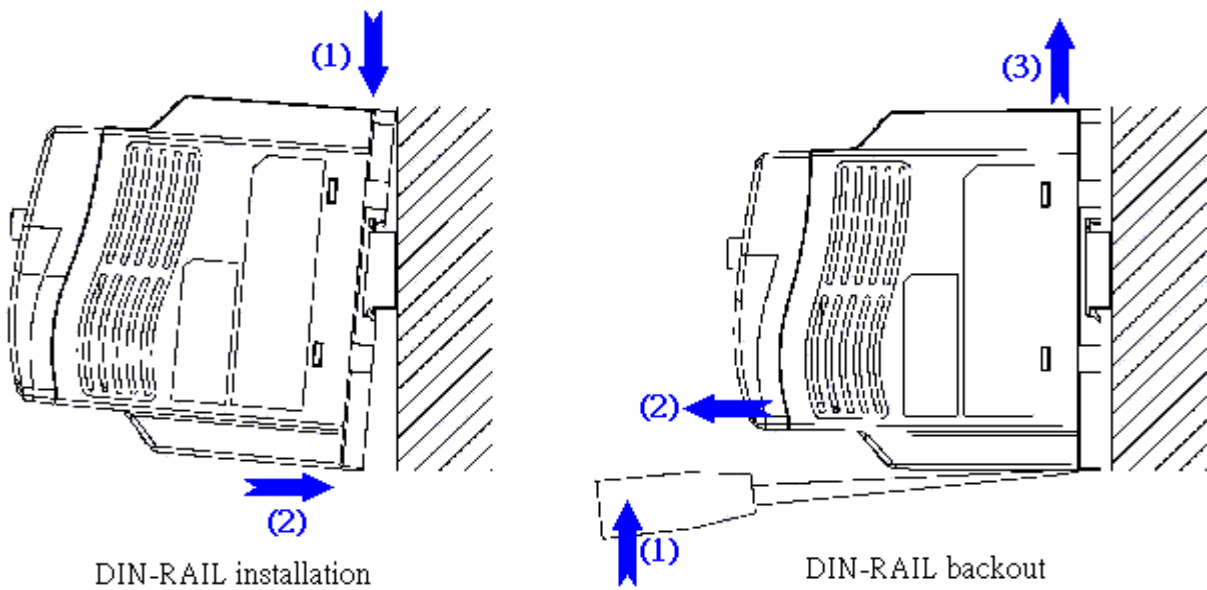

- This model also can be installed Side by Side (with inside temperature below 50 °C).

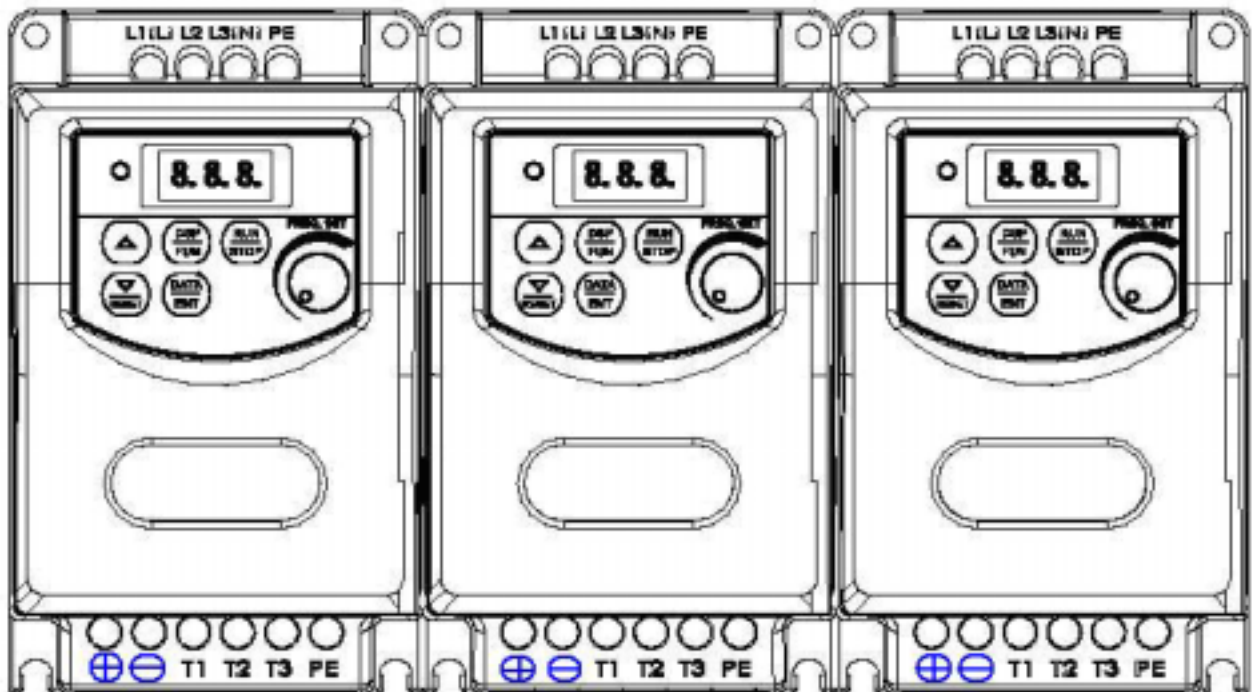

● **EV-1P2/1P5/101/2P2/2P5/201- -N4X(IP65)TYPE INSTALLATION :**

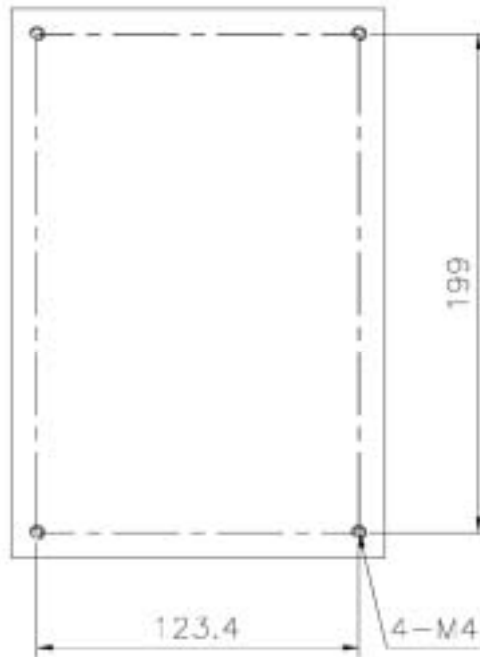
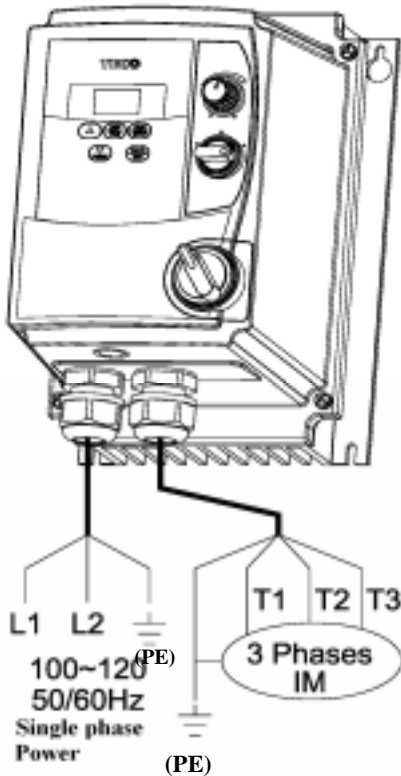

NOTE :

1. POWER SWITCH , REV-0-FWD SWITCH AND Potentiometer are only for EV-1P2~201- N4S TYPE
2. Power supply cable : #14 AGE (2.0m)
3. Motor cable : #16 AGE (1.25m)
4. Torque value of Screw :
 - (1). Power/Motor cable (plug in) Terminal : 5kg-cm(4.34 in-lb)
 - (2). Remote control wire : 4kg-cm(3.47 in-lb)
 - (3). Outer Cover (M4) : 6kg-cm(5.20 in-lb)

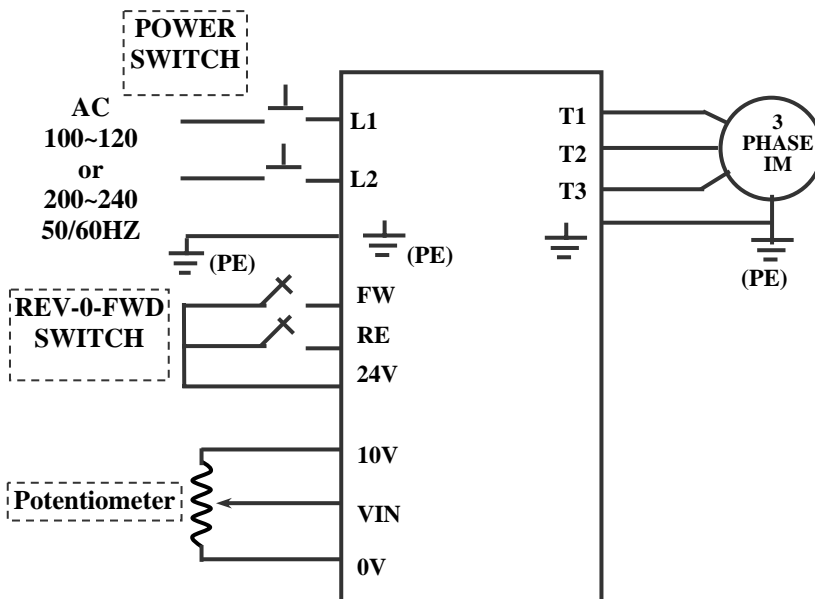

NOTE:

- (1). Input source : single-phase(L1,L2, \perp (PE)) ensuring. that it is connected to a 100~120 or 200~240 supply.
- (2). Output Moter : three-phase(T1,T2,T3, \perp (PE)).
Caution :

Do not start or stop the inverter using the main circuit power.

FOR EV-1P2~201- -N4S TYPE :

Please always remain REV-0-FWD switch at 0 position. In order to keep inverter has no running signal before power-on again after power supply interrupted. Otherwise, injury may result.

FOR EV-1P2~201- -N4S TYPE :

Please always remain RE or FW switch at OFF position. In order to keep inverter has no running signal before power-on again after power supply interrupted. Otherwise, injury may result.

- EV-1P2/1P5/101/2P2/2P5/201- -N4S install :

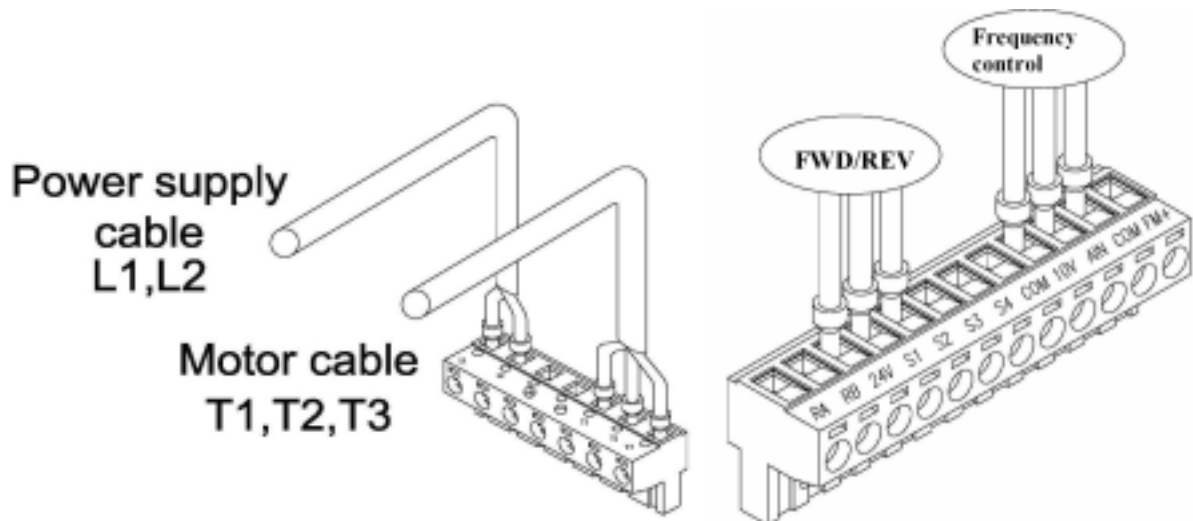
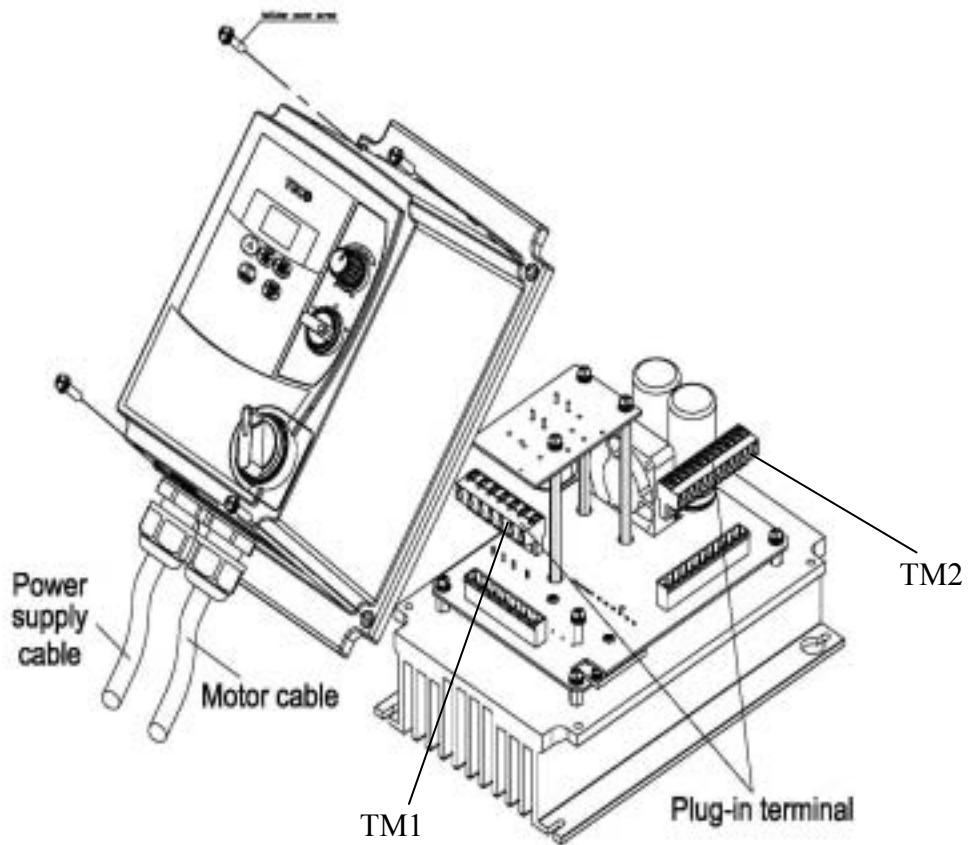

- EV-1P2/1P5/101/2P2/2P5/201- -N4 install :

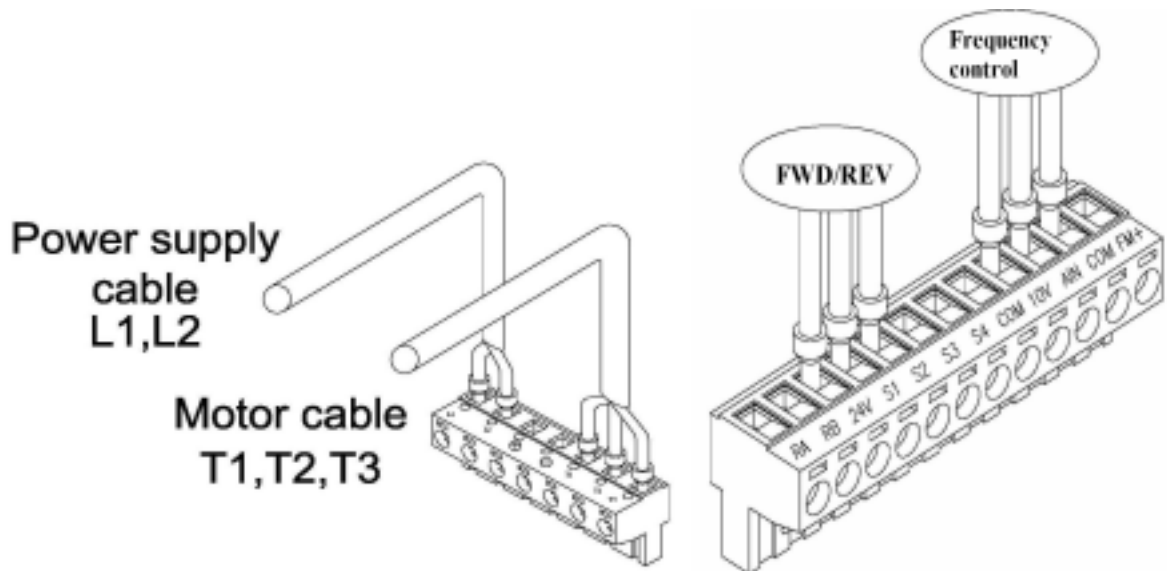
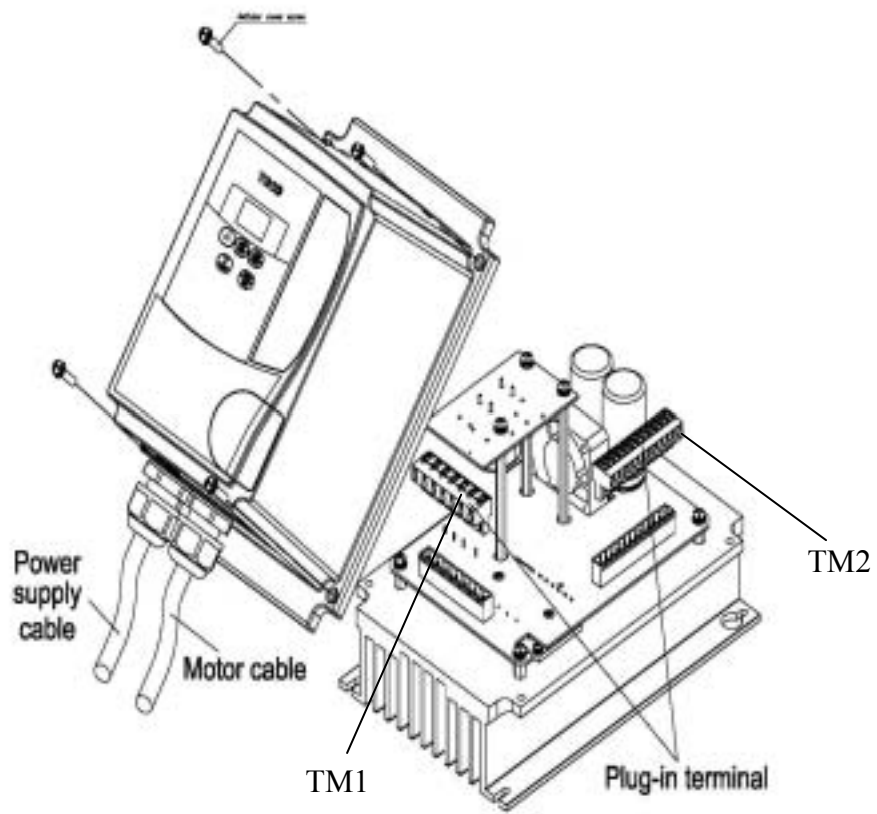

3.2 Environmental precautions

Do not use the inverter in an environment with the following conditions:

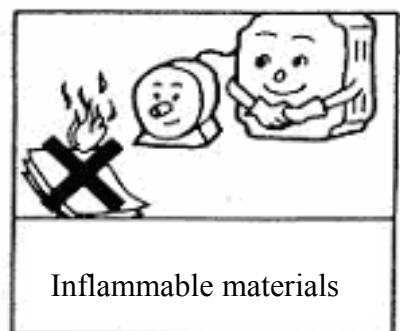
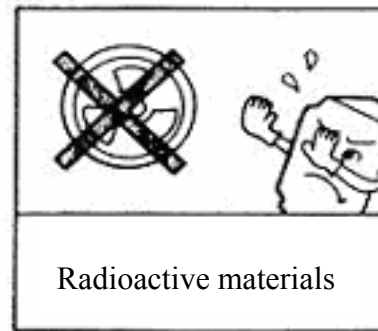
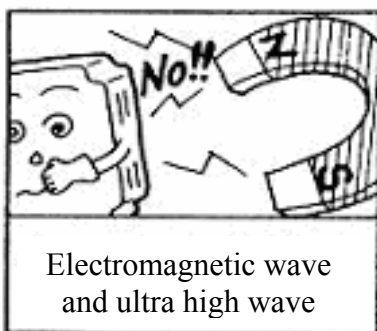
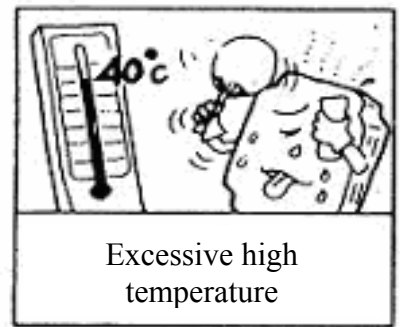
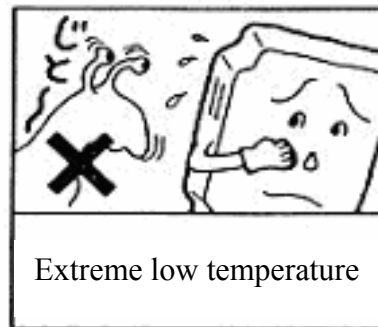
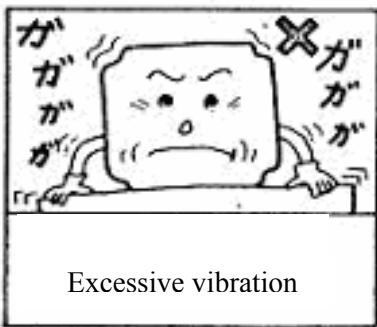
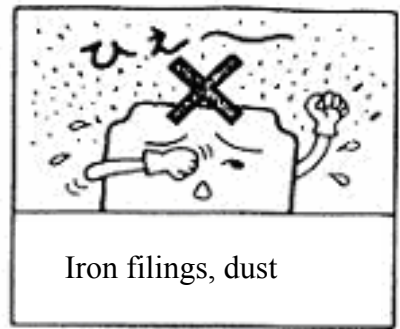
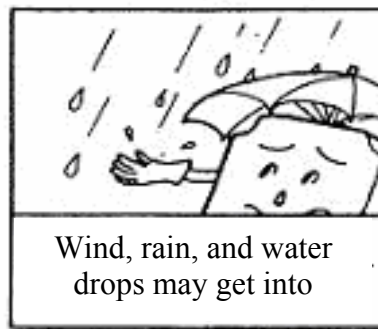
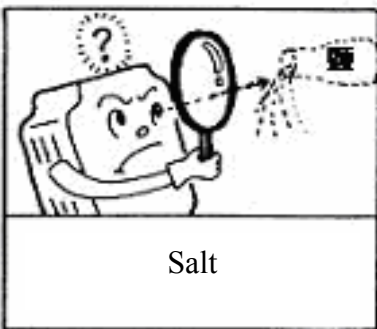
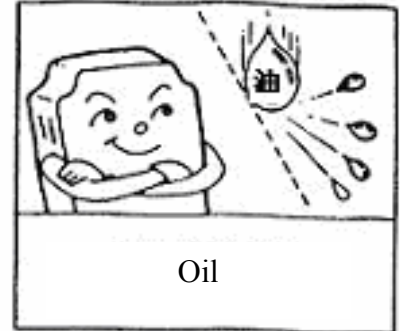
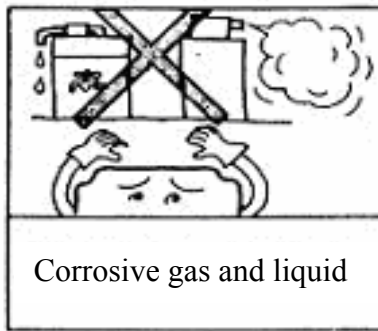
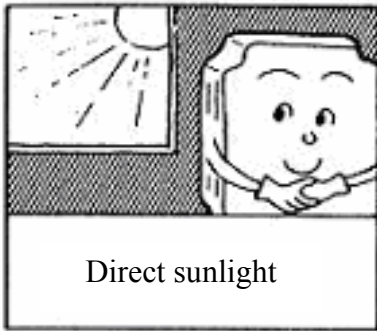

3.3 Wiring Rules

3.3.1 Notice for wiring

A. Screwdriver torque:

Connect cables with a screwdriver or other suitable tools and follow the torque listed below.

| Securing torque | | | |
|-----------------|--------------|---------------------------------|----------------|
| Horsepower | Power source | Nominal torque for TM1 terminal | |
| 0.25/0.5/1 | 100-120V | 0.74/0.1 | 8.66/10 |
| 0.25/0.5/1 | 200-240V | (LBS-FT / KG-M) | (LBS-IN/KG-CM) |
| 2/3 | 200-240V | 1.286/0.18 | 15.97/18 |
| 1/2/3 | 380-480V | (LBS-FT/KG-M) | (LBS-IN/KG-CM) |

B. Power wires:

Power wires are wires connected to L1(L), L2, L3 (N), T1, T2, T3, P and N. Choose wires in accordance with the following criteria:

- (1) Use wires with copper cores only. Select wires of insulating materials with diameters based on working conditions at 105°C.
- (2) For nominal voltage of wires, the minimum voltage of 240Vac type is 300V, and 480Vac type is 600V.

C. Control wire:

Control wire is connected to TM2 control terminal. Choose the wire in accordance with the following criteria:

- (1) Use wires with copper cores only. Select wires of insulating materials with diameters based on working conditions at 105 °C.
- (2) For nominal voltage of wires, the minimum voltage of 240Vac type is 300V, and 480Vac type is 600V.
- (3) To avoid noise interference, do not route the control wire in the same conduit with power wires and motor wires.

D. Nominal electrical specifications of the terminal Block:

The following are nominal values of TM1:

| Horsepower | Power source | Volts | Amps |
|----------------|--------------|-------|------|
| 0.25 / 0.5 / 1 | 100-120V | 600 | 15 |
| 0.25 / 0.5 / 1 | 200-240V | | |
| 2 / 3 | 200-240V | 600 | 40 |
| 1 / 2 / 3 | 380-480V | | |

Note: Nominal values of input and output signals (TM2) – follow the specifications of class 2 wiring.

E. Fuse types

Drive input fuses are provided to disconnect the drive from power in the event that a component fails in the drive’s power circuitry. The drive’s electronic protection circuitry is designed to clear drive output short circuits and ground faults without blowing the drive input fuses. Below table shows the 7300EV input fuse ratings.

To protect the inverter most effectively, use fuses with current-limit function.

RK5, C/T TYPE FUSE FOR 7300EV

110V class(1)

| JNEV- | HP | KW | KVA | 100% CONT Output AMPS (A) | Max.kk5 FUSE Rating(A) | Max.CC or T FUSE Rating(A) |
|--------|------|------|------|------------------------------|---------------------------|-------------------------------|
| 1P2-H1 | 0.25 | 0.2 | 0.53 | 1.7 | 10 | 20 |
| 1P5-H1 | 0.5 | 0.4 | 0.88 | 3.1 | 15 | 30 |
| 101-H1 | 1 | 0.75 | 1.6 | 4.2 | 20 | 40 |

220V class(1)

| JNEV- | HP | KW | KVA | 100% CONT Output AMPS (A) | Max.kk5 FUSE Rating(A) | Max.CC or T FUSE Rating(A) |
|--------|------|------|------|------------------------------|---------------------------|-------------------------------|
| 2P2-H1 | 0.25 | 0.2 | 0.53 | 1.7 | 8 | 15 |
| 2P5-H1 | 0.5 | 0.4 | 0.88 | 3.1 | 10 | 20 |
| 201-H1 | 1 | 0.75 | 1.6 | 4.2 | 15 | 30 |
| 202-H1 | 2 | 1.5 | 2.9 | 7.5 | 20 | 40 |
| 203-H1 | 3 | 2.2 | 4.0 | 10.5 | 25 | 50 |

220V class(3)

| JNEV- | HP | KW | KVA | 100% CONT Output AMPS (A) | Max.kk5 FUSE Rating(A) | Max.CC or T FUSE Rating(A) |
|--------|------|------|------|------------------------------|---------------------------|-------------------------------|
| 2P2-H3 | 0.25 | 0.2 | 0.53 | 1.7 | 5 | 8 |
| 2P5-H3 | 0.5 | 0.4 | 0.88 | 3.1 | 8 | 10 |
| 201-H3 | 1 | 0.75 | 1.6 | 4.2 | 12 | 15 |
| 202-H3 | 2 | 1.5 | 2.9 | 7.5 | 15 | 20 |
| 203-H3 | 3 | 2.2 | 4.0 | 10.5 | 20 | 30 |

440V class(3)

| JNEV- | HP | KW | KVA | 100% CONT Output AMPS (A) | Max.kk5 FUSE Rating(A) | Max.CC or T FUSE Rating(A) |
|--------|----|------|-----|------------------------------|---------------------------|-------------------------------|
| 401-H3 | 1 | 0.75 | 1.7 | 2.3 | 6 | 10 |
| 402-H3 | 2 | 1.5 | 2.9 | 3.8 | 10 | 15 |
| 403-H3 | 3 | 2.2 | 4.0 | 5.2 | 10 | 20 |

*Fuse ratings are based upon 250V fuses for 120V inverters, and 250V fuses for 240V inverters, and 600V for 460V inverters

3.3.2 Suitable MC, MCCB, Fuse and wire specification.**MCCB/ MC/ Fuse**

- TECO warranty and replacement service will not apply under following condition.
 - (1)MCCB or fuse is not installed or unsuitably installed or installed with over capacity, which has resulted in inverter fault.
 - (2)MC or capacitor or surge absorber is connected in series between inverter and motor.

| 7300EV model | JNEV | H1(F)/H3 | | | JNEV | H3(F) |
|---|--|---------------|---------------|---|--|-------|
| | 1P2/2P2/1P5/2P5 | 101/201 | 202 | 203 | 401/402/403 | |
| Fuse | 10A 300Vac | 20A 300Vac | 30A 300Vac | | 15A/600Vac | |
| MCCB Made by TECO | TO-50E 10A | TO-50E 20A | TO-50E 30A | | TO-50E 15A | |
| MC Made by TECO | CN-11 | | | | CN-11 | |
| Main circuit terminal (TM1/TM3)  | Wire dimension 2.0mm ² (14AWG) Terminal screw M4 | | | Wire dimension 3.5mm ² (12AWG) Terminal screw M4 | Wire dimension 2.0mm ² (14AWG) Terminal screw M4 | |
| Signal terminal (TM2) 1~12 | Wire dimension 0.75mm ² (#18AWG) , Terminal screw M3 | | | | | |

- Use a single fuse for 1φ L/N inverter model, for 3φ models, each L1(L)/L2/L3(N) phase must be fused..
- Please select suitable three phase squirrel cage induction motor for inverter.
- If a inverter drives multi motors, please pay attention to current in running should be less than inverter nominal current. Suitable thermistor should be installed on each motor.
- Please do not install capacitor, LC, RC between inverter and motor.

3.3.3 Precautions for peripheral applications:

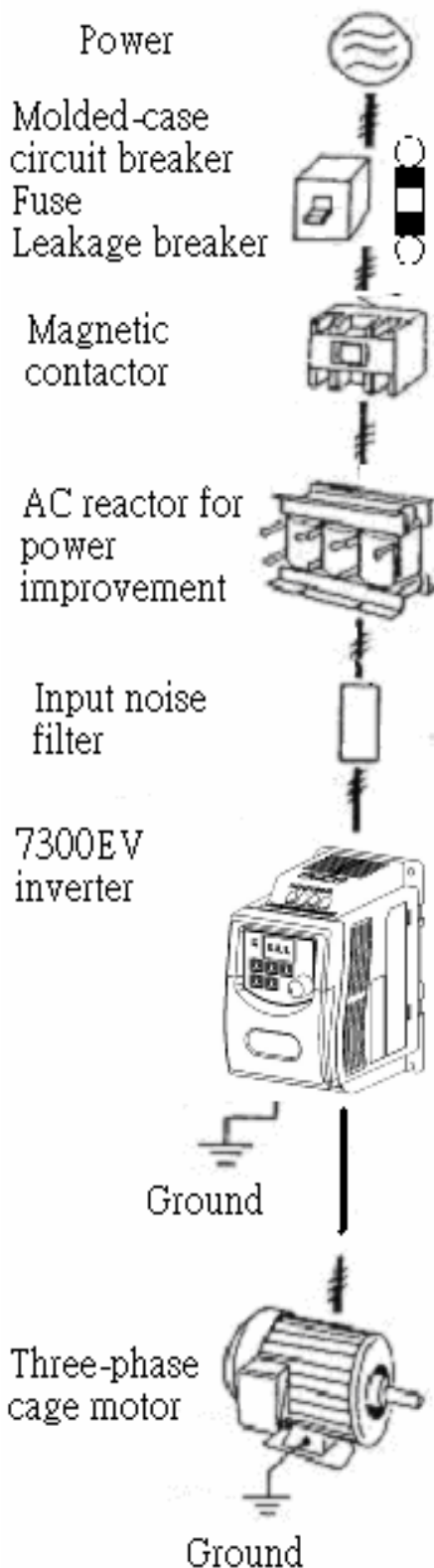

Power supply:

- Make sure the voltage applied is correct to avoid damaging the inverter.
- A molded-case circuit breaker must be installed between the AC source and the inverter.

Molded-case circuit breaker:

- Use a molded-case circuit breaker that conforms to the rated voltage and current of the inverter to control the power ON/OFF and protect the inverter.
- Do not use the inverter as the switch for run/stop switching.

Fuse:

- A suitable fuse should be installed with inverter rated voltage and current to protect inverter when a MCCB has not been used.

Earth Leakage circuit breaker:

- Install a leakage breaker to prevent error operation caused by electric leakage and to protect operators, please choose the current range 200mA upper, and action time 0.1 second upper to prevent high frequency fail.

Magnetic contactor:

- Normal operations do not need a magnetic contactor. But a contactor has to be installed when performing functions such as external control and auto restart after power failure, or when using brake controller.
- Do not use the magnetic contactor as the run/stop switch for the inverter.

AC Reactor for power improvement:

- When inverters are supplied with high capacity (above 600KVA) power source, a AC reactor can be connected to improve the PF.

Input noise filter:

- A filter must be installed when there are inductive load around the inverter.

Inverter:

- Output terminals T1, T2, and T3 are connected to U, V, and W terminals of the motor. If the motor is reversed while the inverter is forward, just swap any two terminals of T1, T2, and T3.
- To avoid damaging the inverter, do not connect the input terminals T1, T2, and T3 to AC power.
- Connect the ground terminal properly. (200 V series: $R_g < 100\Omega$; 400 V series: $R_g < 10\Omega$.)

Make external connections according to the following instruction. Check connections after wiring to make sure all connections are correct. (Do not use the control circuit buzzer to check connections)

(A) Main circuit must be separated from other high voltage or high current power line to avoid noise interference. Refer to following figures:

- The inverter uses dedicated power line rightful results

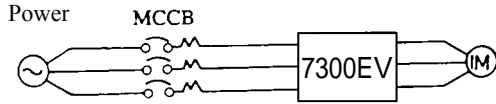

- A general noise filter may not provide

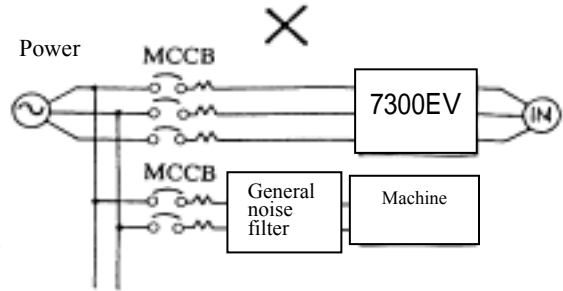

- Please added a noise filter or separation transformer when the inverter shares the power line with other machines.

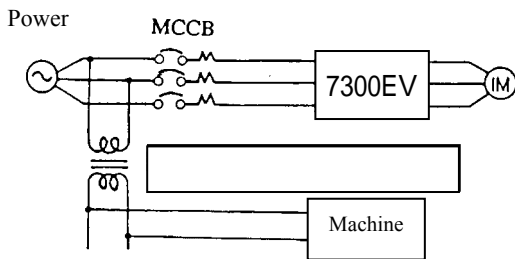
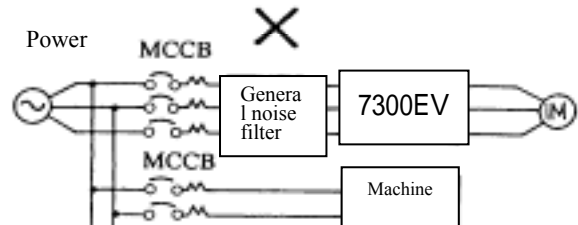
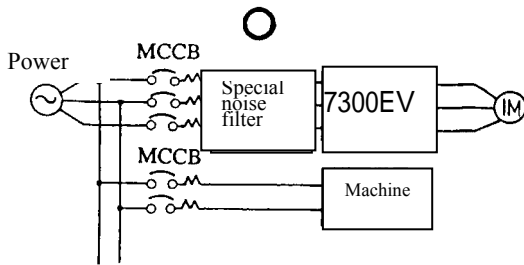

- A noise filter in the output of the main circuit can suppress conductive noise. To prevent radiative noise, the wires should be put in a metal pipe and distance from signal lines of other control machines for more than 30 cm.

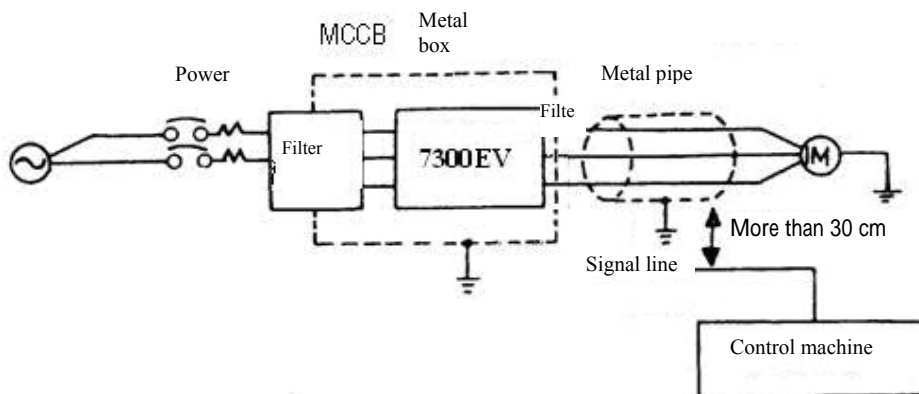

- The supply and output (PE) terminals have to be connected to ground to increase noise immunity of the Filter.

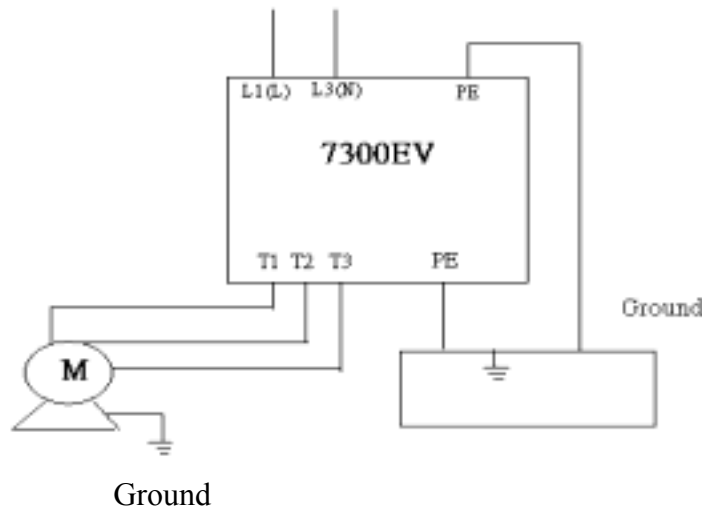

(A) The control circuit wire and main circuit wire/ other high voltage power wire or high current power wire should be separated to avoid noise interruption.

- In order to prevent noise interference resulting in inverter operation error, wire of control circuit should be shielded and twisted. Please refer to following diagram, connect shielded wire to ground terminal. The wiring distance should be less than 50m.

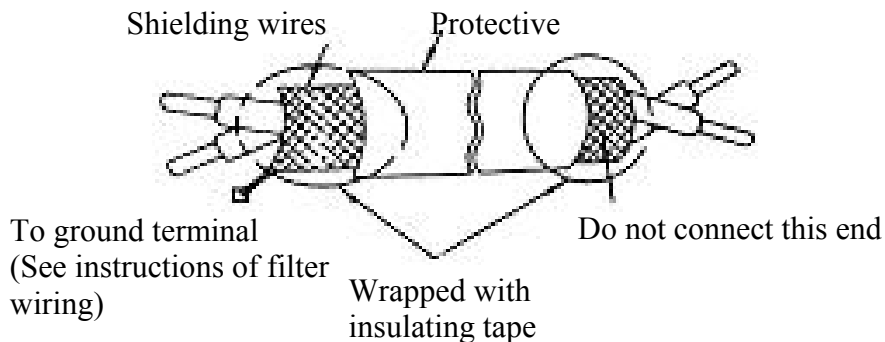

(B) You have to make the ground terminal connect to ground correctly. (200V class ground $<100\Omega$; 400V class ground $<10\Omega$.)

- Ground wiring is based on the electrical equipment technical basis (AWG) and should be made as short as possible.
- Do not share the ground of the inverter to other high current loads (welding machine, high power motor). Connect the terminal to its sole ground.
- Do not make a loop when several inverters share a common ground point.



(a) Good

(b) Good

(c) Bad

(C) To ensure maximum safety, use correct wire size for the main power circuit and control circuit according to the required wiring regulations.

(D) After wiring, check that the wiring is correct, wires are intact, and terminal screws are secured.

3.4 Specification

3.4.1 Product individual specification

| Model | 100V model | | | 200V model | | | | | | | | | | |
|---|---------------------------------------|------|------|---------------------------------------|--------|------|------|------|---------------------------------------|------|------|------|------|--|
| | EV- | -H1 | | EV- | -H1(F) | | | | | EV- | -H3 | | | |
| | 1P2 | 1P5 | 101 | 2P2 | 2P5 | 201 | 202 | 203 | 2P2 | 2P5 | 201 | 202 | 203 | |
| Horse power (HP) | 0.25 | 0.5 | 1 | 0.25 | 0.5 | 1 | 2 | 3 | 0.25 | 0.5 | 1 | 2 | 3 | |
| Suitable motor capacity (KW) | 0.2 | 0.4 | 0.75 | 0.2 | 0.4 | 0.75 | 1.5 | 2.2 | 0.2 | 0.4 | 0.75 | 1.50 | 2.2 | |
| Rated output current (A) | 1.7 | 3.1 | 4.2 | 1.7 | 3.1 | 4.2 | 7.5 | 10.5 | 1.7 | 3.1 | 4.2 | 7.5 | 10.5 | |
| Rated capacity (KVA) | 0.53 | 0.88 | 1.60 | 0.53 | 0.88 | 1.60 | 2.90 | 4.00 | 0.53 | 0.88 | 1.60 | 2.90 | 4.00 | |
| Input voltage range (V) | 1PH 100~120V+10%, -15%(50/60Hz) | | | 1PH 200~240V+10%, -15%(50/60Hz) | | | | | 3PH 200~240V+10%, -15%(50/60Hz) | | | | | |
| Output voltage range (V) | 3PH 0~240V | | | | | | | | | | | | | |
| Input current (A) | 7.1 | 12.2 | 17.9 | 4.3 | 5.4 | 10.4 | 15.5 | 21 | 3.0 | 4.0 | 6.4 | 9.4 | 12.2 | |
| Inverter N.W (KG) | 0.62 | 0.68 | 0.72 | 0.65 | 0.67 | 0.67 | 1 | 1.05 | 0.61 | 0.61 | 0.66 | 0.95 | 1 | |
| Inverter with filter (KG) | | | | 0.71 | 0.73 | 0.73 | 1.25 | 1.3 | | | | | | |
| Allowable momentary power loss time (S) | 1.0 | 1.0 | 1.0 | 1.0 | 1.0 | 1.0 | 2.0 | 2.0 | 1.0 | 1.0 | 1.0 | 2.0 | 2.0 | |
| Enclosure | IP20 | | | | | | | | | | | | | |

| Model | 400V model | | | | | |
|---|---------------------------------|--|------|--------|------|--|
| | EV- | | | -H3(F) | | |
| | 401 | | 402 | | 403 | |
| Horse power (HP) | 1 | | 2 | | 3 | |
| Suitable motor capacity (KW) | 0.75 | | 1.50 | | 2.2 | |
| Rated output current (A) | 2.3 | | 3.8 | | 5.2 | |
| Rated capacity (KVA) | 1.7 | | 2.9 | | 4.0 | |
| Input voltage range (V) | 3PH 380~480V+10%, -15%(50/60Hz) | | | | | |
| Output voltage range (V) | 3PH 0~480V | | | | | |
| Input current (A) | 3 | | 4.8 | | 6.6 | |
| Inverter N.W (KG) | 1.5 | | 1.52 | | 1.55 | |
| Inverter with filter (KG) | 1.68 | | 1.70 | | 1.73 | |
| Allowable momentary power loss time (S) | 1.0 | | 2.0 | | 2.0 | |
| Enclosure | IP20 | | | | | |

Note: 401~403 models release successively.

3.4.2 General Specifications

| | | |
|-----------------------|--------------------------------|---|
| Frequency control | Range | 0~200Hz |
| | Initial Drive | 100%/3Hz (Vector mode) |
| | Speed Control Range | 1:50(Vector mode) |
| | Speed Control Precision | ±0.5%(Vector mode) |
| | Setting resolution 1 | Digital: 0.1Hz(0~99.9Hz)/1Hz(100~200Hz); analog: 0.06Hz/ 60Hz |
| | Keypad setting | Set directly with ▲ ▼ keys or the VR on the keypad |
| | Indication function | 7 segment*3 Displays frequency/DC Voltage/Output Voltage / Current/ inverter parameters/error record/program version/PID feedback control displays |
| | External signal setting | <ul style="list-style-type: none"> •External variable resistor / 0-10V/ 4-20mA •Performs up/down controls with multi-functional contacts on the terminal base |
| | Frequency limit function | Respectively setting up upper/lower frequency limits, and two-stage prohibited frequencies. |
| General control | Carrier frequency | 4~16KHz (default 10KHz, above 10KHz with De-rating) |
| | V/F pattern | 6 fixed pattern 50Hz/60Hz, 1 programmable |
| | Acc/dec control | Two-stage acc/dec time (0.1~999s) |
| | Multi-functional analog output | 6 functions (refer to F26 description) |
| | Multi-functional input | 19 functions (refer to F11~F14 description) |
| | Multi-functional output | 16 functions (refer to F21 description) |
| | DI(digital input) | NPN/PNP alternative : 4 points built-in ; 2 points option (S1~S4 Built in,S5~S6 option) |
| | DO(digital output) | Relay output *build in 1 point (1a terminal)---- set to multi-function output. External multi-function output *option 1 point (open collector transistor 24V, 600mA) |
| | AI(analog input) | Set speed command and PID feedback signal (speed ,PID 4~20mA /0~10V)or MFIT S7 |
| | Other function | Instantaneous power loss restart, Speed search, fault restart, DC brake, torque boost, 2/3wire control and PID function |
| Communication control | Communication control | <ul style="list-style-type: none"> •RS485 Option card : Modbus RTU/ASCII mode, 4800~38400 bps, max. 254 stations •PC/PDA software |
| | Operation temperature | -10~50 (inside distributor) IP20 ; -10~40 IP65 |
| | Storage temperature | -20~60 |
| | Humidity | 0 – 95% RH (non condensing) |
| | Vibration immunity | 1G(9.8m/s ²) |
| | EMC 2 | Built-in class B/ external: class A ; accordance with EN61800-3 first non limit/ limit environment |
| | LVD | Accordance with EN50178 |
| | Enclosure | IP20 |
| | Safety Class | UL508C |

| | | |
|----------------------|----------------------------------|--|
| Protective Functions | Over load protection | Inverter rated current 150%/1min |
| | International conformity | UL/CE |
| | Over voltage | 200V Class: DC voltage >400V 400V Class: DC voltage >800V |
| | Under voltage | 200V Class: DC voltage <190V 400 Class: DC voltage <380V |
| | Instantaneous power loss restart | Set to enable or disable |
| | Stall prevention | ACC/DEC/ Operation stall prevention and stall prevention level. |
| | Output terminal short circuit | Electronic circuit protection |
| | Other fault | Electronic circuit protection |
| | Other function | Over current, over voltage, under voltage, over load, instantaneous power loss restart, ACC/DEC/ Operation stall prevention, output terminal sort circuit, grounding error, reverse limit, directly start as power on and fault reset limit. |

Note1: The setting resolution of above 100 Hz is 1Hz when controlled with operation keypad, and 0.01 Hz when controlled using computer(PC) or programmable controller(PLC).

**Note2: EV-1P2~101-H1 ; 2P2~201-H1/H3 , 401~403-H3 type (Fc=10KHz) with option filter can accordance with EN61800-3 first environment restricted distribution.
EV-202~203-H1/H3 type (Fc=10KHz) with option filter can accordance with EN61800-3 first environment unrestricted distribution.
EV-2P2~201-H1F type (Fc=10KHz) & EV-202~203-H1F type (Fc=6KHz) with Build in filter can accordance with EN61800-3 first environment unrestricted distribution.
(IP65) EV-2P2~403-H1(3)FN4(S) series & EV-401~403-H3F type (Fc=10KHz) with Build in filter can accordance with EN61800-3 first environment restricted distribution.**

3.5 7300EVWiring diagram

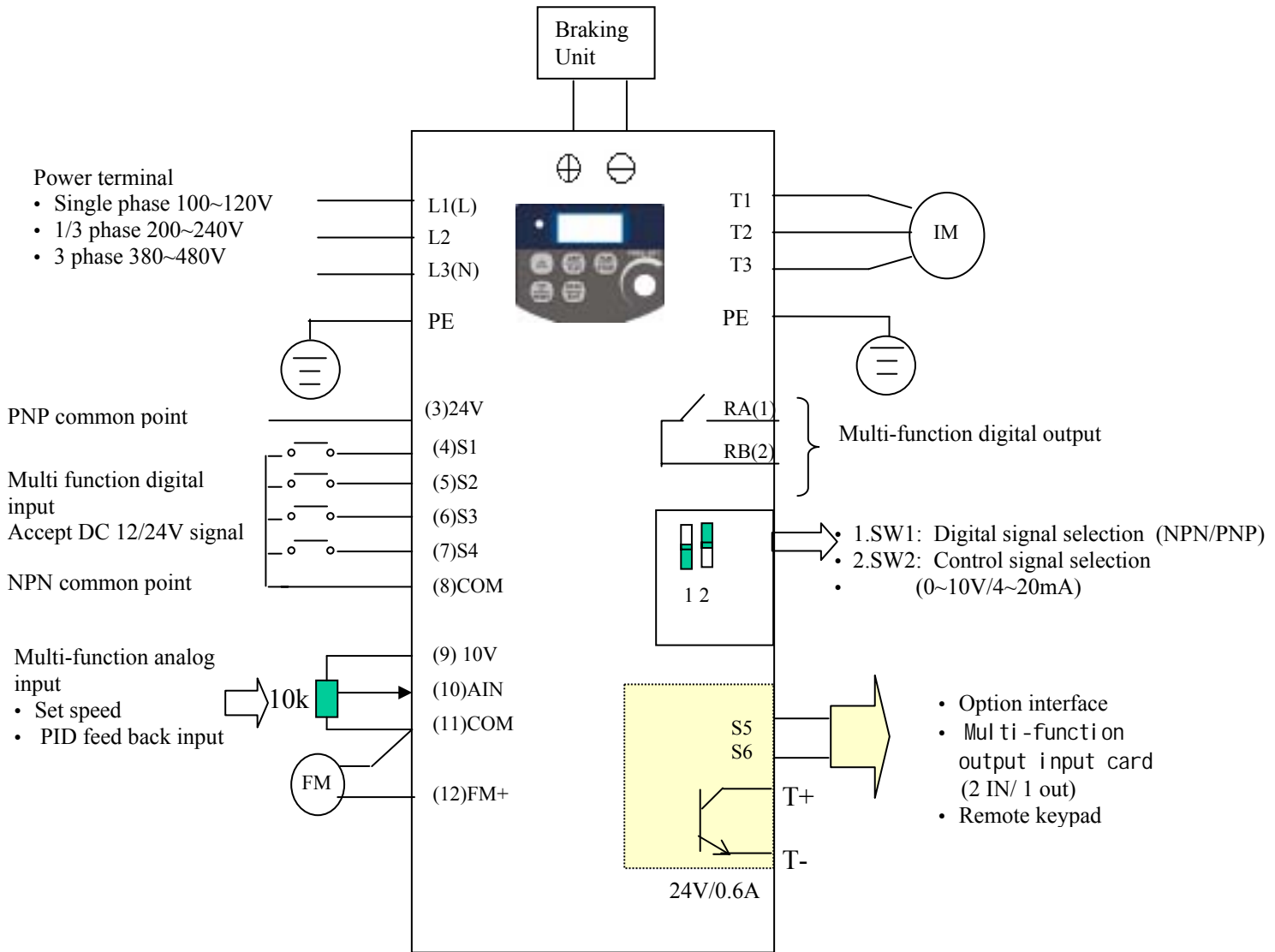

Note 1:- Connect point X to Terminal 3 (internal 24vdc) for PNP mode (Positive switching) .
Or to terminal 8 (Common) for NPN mode(Negative switching) .

Note2:- External 24 Vdc may be used to supply the external contacts at point X
If so then connect the 0V of the external supply to Common (terminal 8).

3.6 Description of Inverter Terminal

Descriptions of power terminals

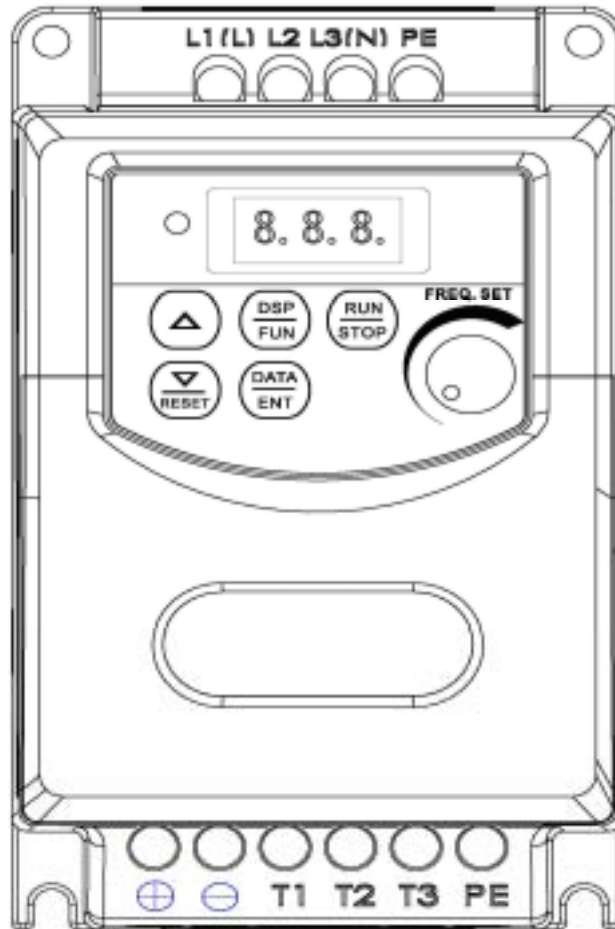

| Symbol | Description |
|--------|---|
| L1 (L) | Main power input Single-phase: L/N Three-phase: L1/L2/L3 |
| L2 | |
| L3 (N) | |
| ⊕ | DC power and braking unit connect terminals, applied in large load inertia or short deceleration time and inverter tender to trip. (matching with Braking Unit and brake resistor to brake) |
| ⊖ | |
| T1 | Inverter output |
| T2 | |
| T3 | |
| PE | Grounding terminal (2 points) |

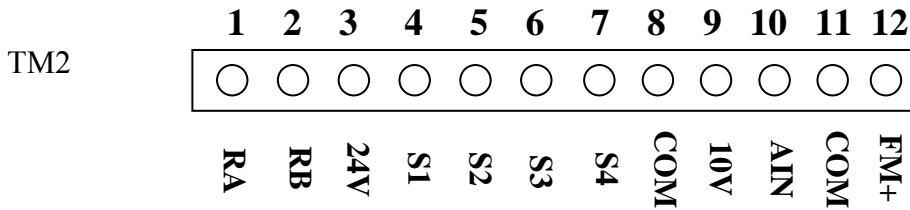

* Brake units are required for applications where a load with high inertia needs to be stopped rapidly. Use a correctly rated braking unit and resistor to dissipate the energy generated by the load while stopping. Otherwise inverter will trip on overvoltage.



Control signal terminals block description

| Symbol | Description | |
|--------|--|--|
| RA | Multi-functional output terminal Normally open contact | Rated contact capacity: (250VAC/10A) Contact description: (refer to F21) |
| RB | | |
| 10V | Supply for external potentiometer for speed reference. | |
| AIN | Analog frequency signal input terminal or multi-function input terminal S7 (high level :upper than 8V/low level: lower than 2V,adapt to PNP (refer to F15 description) | |
| 24V | PNP (SOURCE)input, S1~S4(S5/S6/S7)common terminal, please set SW1 to PNP and connect option card power. | |
| COM | NPN (SINK)input, S1~S4 (S5/S6)common terminal, please set SW1 to NPN, and analog input, connect option card power, output signal common terminal. | |
| FM+ | Multi-function analog output terminal + terminal, (refer to F26description), output signal: DC 0-10V. | |

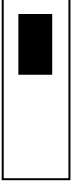
| Symbol | Description |
|--------|--|
| S1 | Multi-function input terminal (refer to F11~F14 description) |
| S2 | |
| S3 | |
| S4 | |

SW function description

| SW1 | Type of external signal | Remarks |
|---|-------------------------|-----------------|
|  | NPN input (SINK) | |
|  | PNP input (SOURCE) | Factory default |

| SW2 | Type of external signal | Remarks |
|---|-------------------------|-------------------------------|
|  | 0~10V DC analog signal | Effective when external F05=2 |
|  | 4~20mA analog signal | |

3.7 Dimension

- (1) IP20 Frame1: Single phase JNEV-1P2~201-H1/H1F
 Three phase JNEV-2P2~201-H3

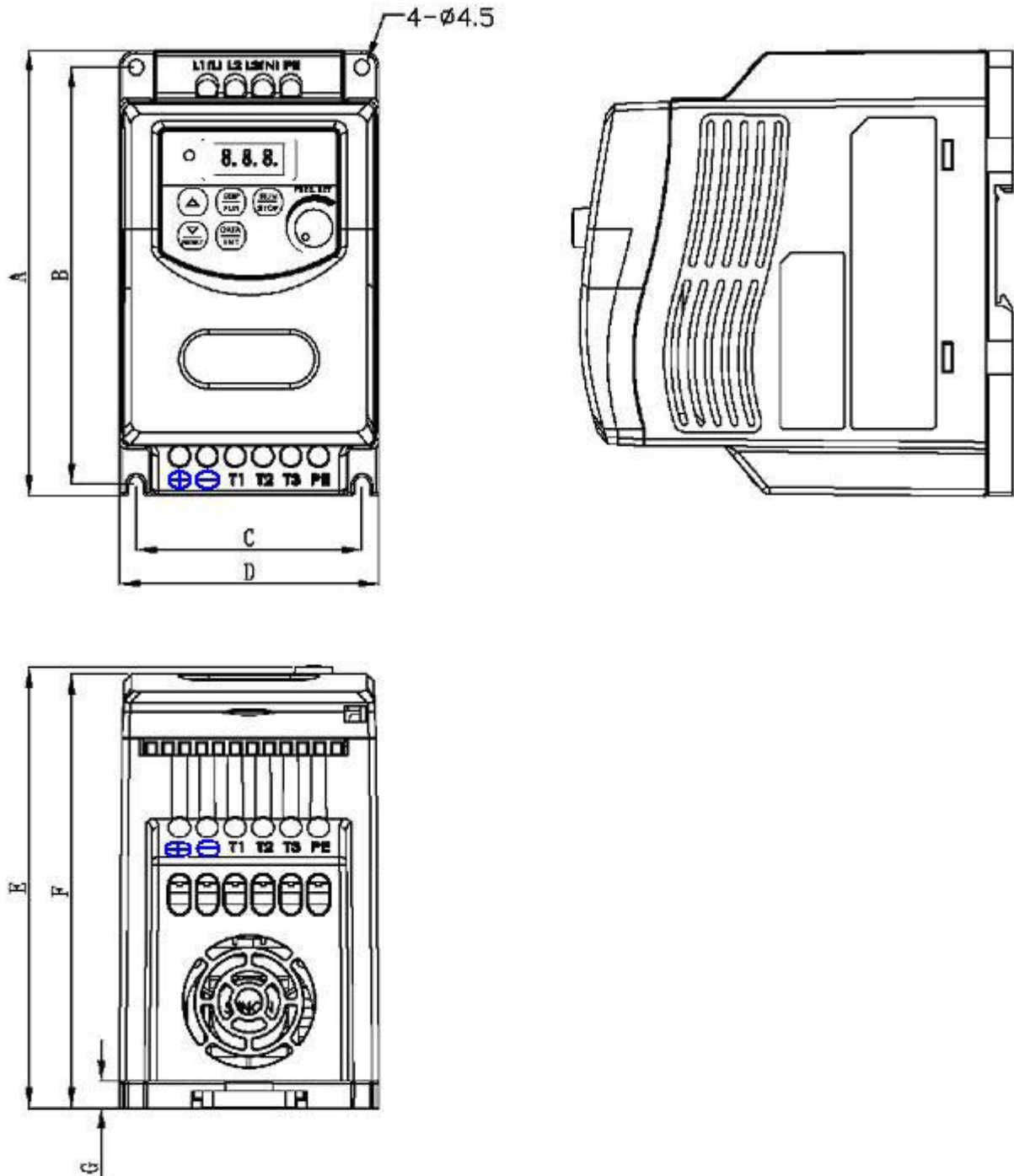

- (2) IP20 Frame2: Single phase JNEV-202~203-H1/H1F
- Three phase JNEV-202~203-H3
- Three phase JNEV-401~403-H3/H3F

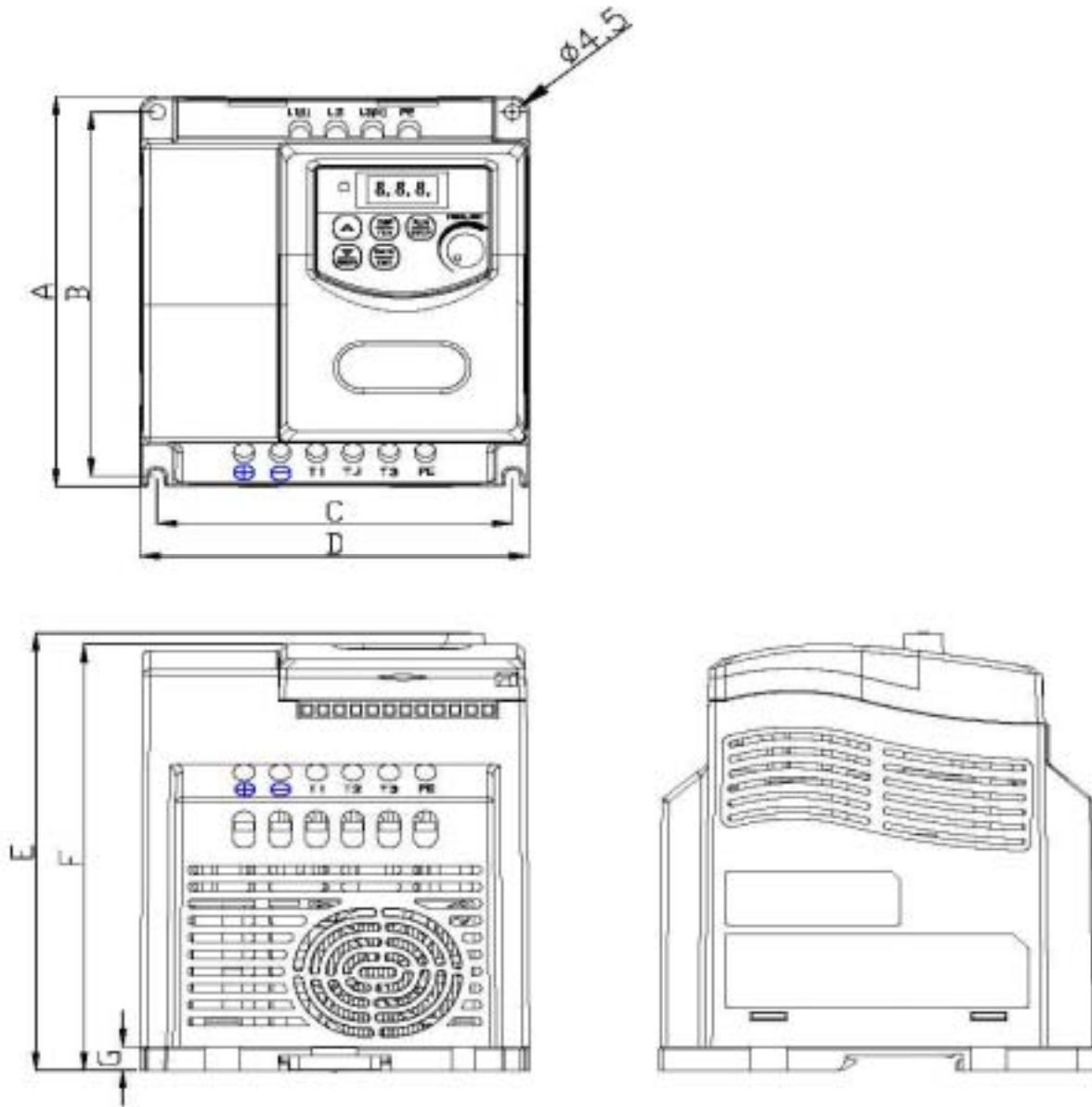

Unit: mm/inch

| LENGTH | | A | B | C | D |
|--------|---------|------------|-------------|----------|----------|
| MODEL | Frame 1 | 132/5.2 | 123.5/4.86 | 67/2.64 | 77/3.03 |
| MODEL | Frame 2 | 132/5.2 | 123.5/4.86 | 108/4.25 | 118/4.65 |
| LENGTH | | E | F | G | |
| MODEL | Frame 1 | 130.5/5.13 | 128.45/5.06 | 8/0.315 | |
| MODEL | Frame 2 | 148/5.83 | 144/5.67 | 8/0.315 | |

(3) IP65 Frame1(switch) EV-1P2/1P5/101/2P2/2P5/201-N4S(IP65 type) :

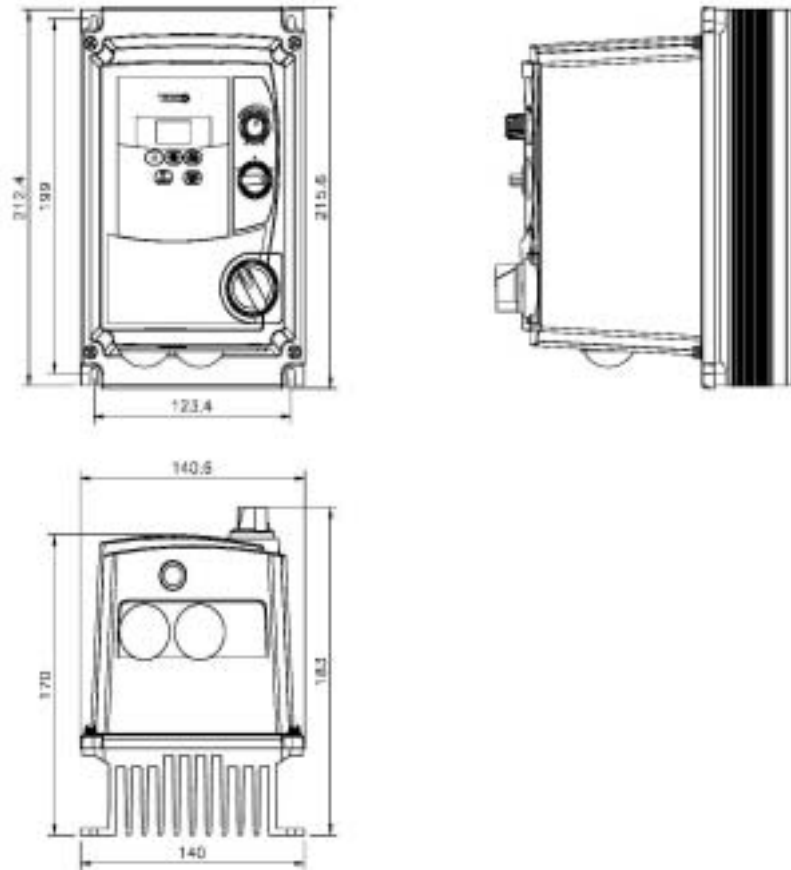

● IP65 Frame1(no switch) EV-1P2/1P5/101/2P2/2P5/201-N4(IP65 type) :

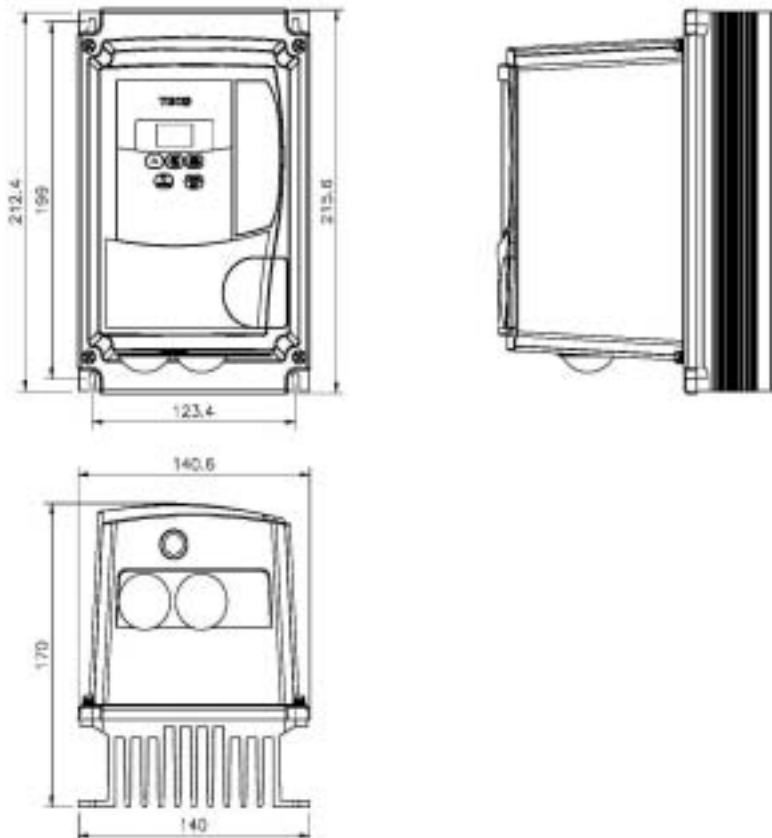

3.8 Installation and design consideration

must power on the same time
 (On the same power system permit ⊕⊕ bus parallel connection)

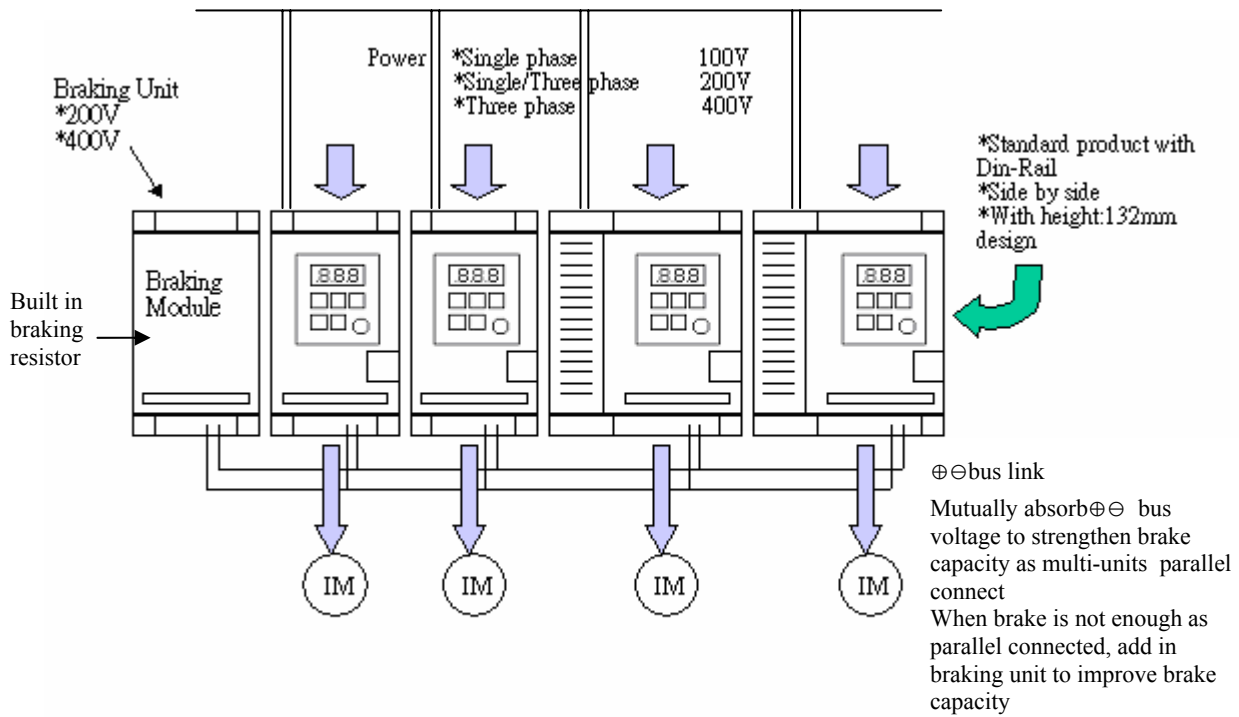

1. On the same power system permit ⊕⊕ bus parallel connection.
2. If want to parallel connection the other brand inverter or more large capacity inverter must be use MC with ⊕⊕ bus parallel connector can avoid inverter break.

Chapter 4 Programming instructions & Parameter list

4.1 Keypad description

4.1.1 Keypad display and operation instruction

Power LED (Red)



4.1.2 Operation Instruction of the keypad

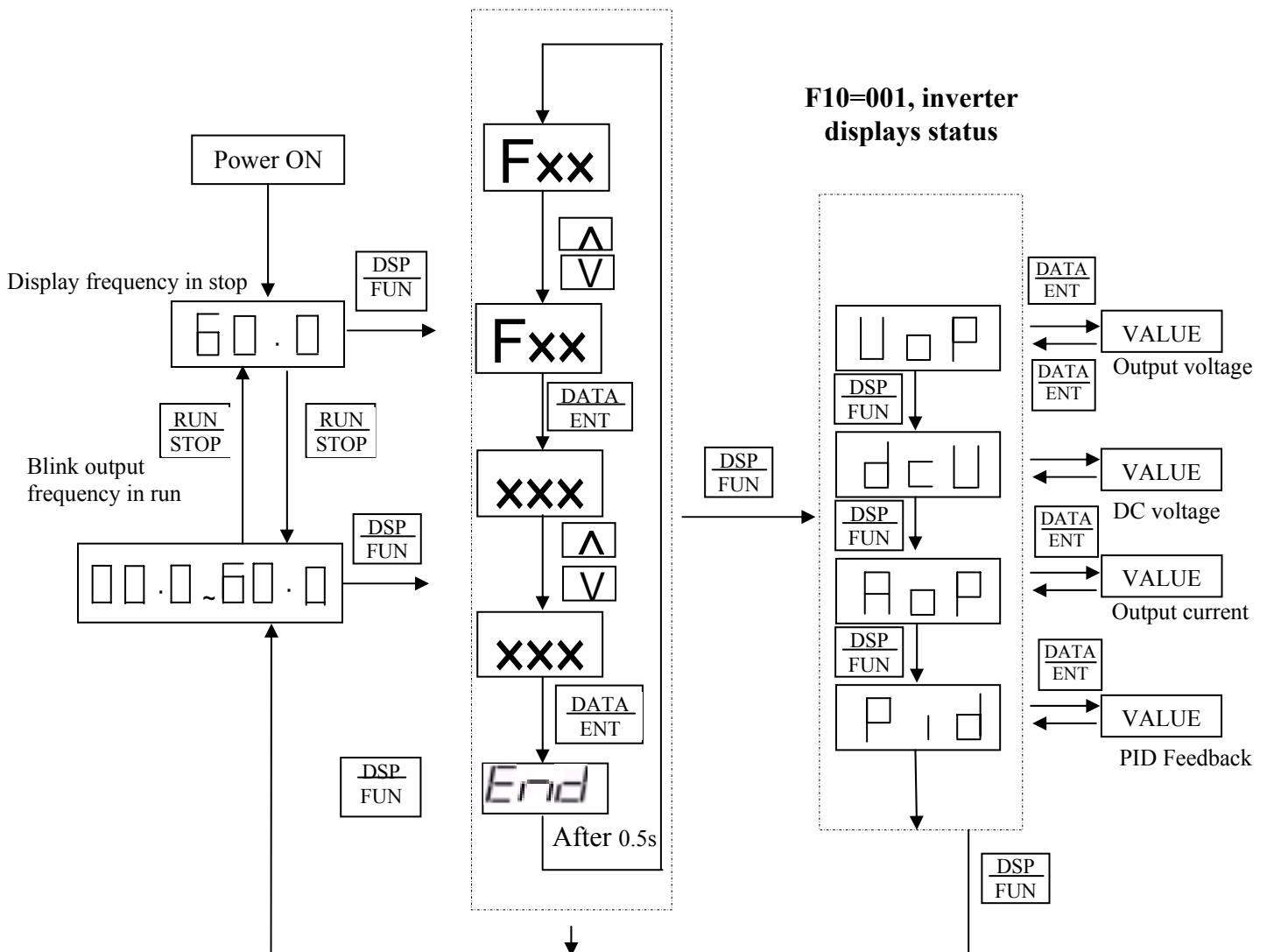

*1 : Display flashes with set frequency in stop mode, but it is static in run mode.

*2 : The frequency can be set during both stop and run.

- **Remote/Local change function**

- **Local mode**

- Run command only **RUN/STOP** pad on the keypad can control and Run parameter **(F04)** don't care

- Frequency command

- When C41=000: only UP/DOWN pad on the keypad can control and F05 setting have no relationship.

- When C41=001: only VR on the keypad can control and F05 setting have no relationship.

- **Remote mode**

- Run command from Run parameter **(F04)** set to control

- Frequency command from Frequency parameter **(F05)** set to control

- **Remote/Local change mode complex keypad are /RESET and DATA/ENT pad on the same time push down can change Remote/Local mode(the inverter must to stop)**

4.2 Parameter function list

Basic parameter function list

| F | Function Description | Range/ Code | Factory Default | Remarks |
|----|---------------------------------|---|-----------------|---------|
| 00 | Inverter horse power code | | | |
| 01 | Acceleration time 1 | 00.1~999s | 05.0 | *1 *2 |
| 02 | Deceleration time 1 | 00.1~999s | 05.0 | *1 *2 |
| 03 | Motor rotating direction | 000: Forward 001: Reverse | 000 | *1 |
| 04 | Run command from | 000: keypad 001: External Terminal 002: Communication Control | 000 | |
| 05 | Frequency command from | 000: UP/Down Key on control panel 001: VR on control panel 002: AIN input signal from (TM2) 003: Multi-function input terminal UP/DOWN function 004: Communication frequency set | 000 | |
| 06 | External control operation mode | 000: Forward/ Stop-Reverse/Stop 001: Run/ Stop-Forward/Reverse 002:3-wire—Run/ Stop | 000 | |
| 07 | Frequency upper limit | 01.0 ~200Hz | 50.0/60.0 | *2 |
| 08 | Frequency lower limit | 00.0 ~200Hz | 00.0 | *2 |
| 09 | Stopping method | 000: Decelerate to stop 001: Free run to stop | 000 | |
| 10 | Status display parameters | 000: No display 001: Display | 000 | *1 |
| 11 | Terminal S1 Function | 000: Forward 001: Reverse | 000 | |
| 12 | Terminal S2 Function | 002: Preset Speed Command 1 003: Preset Speed Command 2 004: Preset Speed Command 3 | 001 | |
| 13 | Terminal S3 Function | 005: Jog frequency Command 006: Emergency stop(E.S.) 007: Base Block (b.b.) | 005 | |
| 14 | Terminal S4 Function | 008: Select 2 nd accel / decel time 009: Reset 010: Up command 011: Down command 012: Control signal switch 013: Communication control signal switch 014: Acceleration/deceleration prohibit 015: Master/Auxiliary speed source select 016: PID function disable | 006 | |
| 15 | Terminal AIN Function | 017: Analog frequency signal input(terminal AIN) 018: PID feedback signal (terminal AIN) | 017 | |
| 16 | AIN signal select | 000: 0~10V 001: 4~20mA | 000 | |
| 17 | AIN Gain (%) | 000~200 | 100 | *1 |
| 18 | AIN Bias (%) | 000~100 | 000 | *1 |

| | | | | |
|----|---|--|------|----|
| 19 | AIN Bias | 000: Positive 001: Negative | 000 | *1 |
| 20 | AIN .Slope Direction | 000: Positive 001: Negative | 000 | *1 |
| 21 | Multi-function output RY1 | 000: In running 001: Frequency reached (Set frequency \pm F23) 002: Frequency is within the range set by (F22 \pm F23) 003: Frequency Detection (>F22) 004: Frequency Detection (<F22) 005: Fault terminal 006: Auto reset and restart 007: Momentary power loss 008: Emergency Stop(E.S.) 009: Base Block (b.b.) 010: Motor overload protection 011: Inverter overload protection 012: retain 013: Power On 014: Communication error 015: Output current detection(>F26) | 000 | |
| 22 | Output frequency reached the Set value (Hz) | 00.0~200 | 00.0 | *1 |
| 23 | Frequency detection range (\pm Hz) | 00.0~30.0 | 00.0 | *1 |
| 24 | Output current reach set value | 000~100% | 000 | |
| 25 | Output current detection time | 00.0~25.5(Sec) | 00.0 | |
| 26 | Multi-function output analog type selection (0~10Vdc) | 000: Output frequency 001: Set frequency 002: Output voltage 003: DC voltage 004: Output current 005: PID feedback signal | 000 | *1 |
| 27 | Multi-function analog output gain (%) | 000~200 | 100 | *1 |
| 28 | Preset frequency 1 (Main frequency instruction) | 00.0~200Hz | 05.0 | *1 |
| 29 | Preset frequency 2 | 00.0~200Hz | 05.0 | *1 |
| 30 | Preset frequency 3 | 00.0~200Hz | 10.0 | *1 |
| 31 | Preset frequency 4 | 00.0~200Hz | 20.0 | *1 |
| 32 | Preset frequency 5 | 00.0~200Hz | 30.0 | *1 |
| 33 | Preset frequency 6 | 00.0~200Hz | 40.0 | *1 |
| 34 | Preset frequency 7 | 00.0~200Hz | 50.0 | *1 |
| 35 | Preset frequency 8 | 00.0~200Hz | 60.0 | *1 |
| 36 | Jog frequency instruction | 00.0~200Hz | 05.0 | *1 |
| 37 | DC braking time | 00.0~25.5 Sec | 00.5 | |
| 38 | DC braking start frequency | 01.0~10.0 Hz | 01.5 | |

| | | | | |
|----|-------------------------------------|--|-----|-------|
| 39 | DC braking level | 000~020% | 005 | |
| 40 | Carrier frequency | 004~016 | 010 | 4~16K |
| 41 | Restart for momentary power loss | 000: Enable 001: Disable | 000 | |
| 42 | Auto-restart times | 000~005 | 000 | |
| 43 | Motor rated current | | | *4 |
| 44 | Motor rated voltage | | | *4 |
| 45 | Motor rated frequency | | | *4 |
| 46 | Motor rated power | | | *4 |
| 47 | Motor rated speed | | | *4 |
| 48 | Torque Boost Gain (Vector) | 001~450 | | |
| 49 | Slip Compensation Gain (Vector) | 001~450 | | |
| 50 | Low frequency voltage compensation | 000~40 | | |
| 51 | Advanced parameter function display | 000: non-display 001: display | 000 | *1 |
| 52 | Factory default | 010: Reset to factory default (50Hz) 020: Reset to factory default (60Hz) | 000 | |
| 53 | Software version | CPU Version | | *3 *4 |
| 54 | Latest 3 fault records | | | *3 *4 |

Advanced function parameter list(Enable access to these parameters by setting F51=001)

| C | Function Description | Range/ Code | Factory default | Remarks |
|----|---|--|-----------------|---------|
| 00 | Reverse run instruction | 000: Reverse enable 001: Reverse disable | 000 | |
| 01 | Acceleration stall-prevention | 000: Acceleration stall prevention enable 001: Acceleration stall prevention disable | 000 | |
| 02 | Acceleration stall-prevention level (%) | 050 - 200 | 200 | |
| 03 | Deceleration stall-prevention | 000: Deceleration stall prevention enable 001: Deceleration stall prevention disable | 000 | |
| 04 | Deceleration stall-prevention level (%) | 050 - 200 | 200 | |
| 05 | Run stall-prevention | 000: Run stall prevention available 001: Run stall prevention unavailable | 000 | |
| 06 | Run stall-prevention level (%) | 050 - 200 | 200 | |
| 07 | Stall prevention time in running | 000: according to decel time set in F02 001: according to decel time set in C08 | 000 | |
| 08 | Stall prevention deceleration time set | 00.1 – 999 Sec | 03.0 | |
| 09 | Direct start as power on | 000: Directly start available 001: Directly start unavailable | 001 | |
| 10 | Reset mode | 000: RUN instruction is OFF, Reset command is available. 001: Whether RUN instruction is OFF or ON, Reset command is available. | 000 | |

| | | | | |
|----|---|---|-----------|---|
| 11 | Acceleration time 2 | 00.1~999 Sec | 05.0 | *1 *2 |
| 12 | Deceleration time 2 | 00.1~999 Sec | 05.0 | *1 *2 |
| 13 | Fan control | 000: Auto-run by inverter temperature 001: Run when inverter running 002: Always run 003: Always stop | 001 | This function only available for IP20 type, For IP65 type , fan will be run while power on. |
| 14 | Control mode | 000:Vector control 001:V/F Control | 000 | *4 |
| 15 | V/F Pattern set | 001 ~ 007 | 001/004 | |
| 16 | VF base output voltage set | 198~265V / 380~530V | 220/440 | |
| 17 | Max output frequency (Hz) | 00.2 – 200 | 50.0/60.0 | |
| 18 | Output voltage ratio for max frequency (%) | 00.0 – 100 | 100 | |
| 19 | Mid frequency(Hz) | 00.1 – 200 | 25.0/30.0 | |
| 20 | Output voltage ratio for mid frequency (%) | 00.0 – 100 | 50.0 | |
| 21 | Min output frequency (Hz) | 00.1 – 200 | 00.5/00.6 | |
| 22 | Output voltage ratio for Min frequency (%) | 00.0 – 100 | 01.0 | |
| 23 | Torque Boost Gain (V/F) | 00.0 ~ 30.0% | 00.0 | *1 |
| 24 | Slip Compensation Gain (V/F) | 00.0 ~100% | 00.0 | *1 |
| 25 | Motor no load current | | | According to motor rating *4 |
| 26 | Electronic thermal relay protection for motor (OL1) | 000: Enable protect motor 001: Disable protect motor | 000 | |
| 27 | Skip frequency 1(Hz) | 00.0~200 | 00.0 | *1 |
| 28 | Skip frequency 2(Hz) | 00.0~200 | 00.0 | *1 |
| 29 | Skip frequency range (±Hz) | 00.0~30.0 | 00.0 | *1 |
| 30 | PID operation mode | 000: PID Function unavailable 001: PID control, Bias D control 002: PID Control, Feedback D control 003: PID Control, Bias D reverse characteristics control. 004: PID Control, Feedback D reverse characteristics control. | 000 | |
| 31 | Feedback gain | 0.00 – 10.0 | 1.00 | *1 |
| 32 | P: Proportion gain | 0.00 – 10.0 | 01.0 | *1 |

| | | | | |
|----|--|---|------|----|
| 33 | I: Integral time (s) | 00.0 – 100 | 10.0 | *1 |
| 34 | D: Differential time (s) | 0.00 – 10.0 | 0.00 | *1 |
| 35 | PID OFFSET | 000: Positive direction 001: Negative direction | 000 | *1 |
| 36 | PID OFFSET adjust (%) | 000 – 109 | 000 | *1 |
| 37 | PID postpone time (s) | 00.0 - 02.5 | 00.0 | *1 |
| 38 | PID Sleep starting level | 00.0~200Hz | 00.0 | |
| 39 | PID Sleep postpone time | 00.0~25.5 | 00.0 | |
| 40 | Frequency Up/ Down control using MFIT | 000: UP/Down command is available. Set frequency is held when inverter stops. 001: UP/Down command is available. Set frequency reset to 0Hz when inverter stops. 002: UP/Down command is available. Set frequency is held when inverter stops. Up/Down is available in stop. | 000 | |
| 41 | Local/Remote frequency control select (Run command by the Run/Stop pad of the keypad) | 000: UP/Down pad on keypad set frequency 001: VR on the keypad set frequency | 000 | |
| 42 | Terminal S5 function (option) | 000: Forward 001: Reverse 002: Preset Speed Command 1 003: Preset Speed Command 2 004: Preset Speed Command 3 005: Jog Frequency Command 006: Emergency Stop(E.S.) 007: Base Block (b.b.) 008: Select 2 nd accel/decel time. 009: Reset | 007 | |
| 43 | Terminal S6 function (option) | 010: Up Command 011: Down Command 012: Control signal switch 013: Communication control signal switch 014: Acceleration/ deceleration disable 015: Master/auxiliary speed source select 016: PID function disable | 009 | |
| 44 | Multi-function input terminal S1~S6 signal scan time (mSec ×8) | 001~100 | 010 | |
| 45 | Confirming AIN signal scan time (mSec x 8) | 001~100 | 050 | |

| | | | | |
|----|--|---|------|---|
| 46 | Multi-function output T+ , T- (option) | 000: In running 001: Frequency reached (Set frequency \pm F23) 002: Frequency is within the range set by (F22 \pm F23) 003: Frequency detection (>F22) 004: Frequency detection (<F22) 005: Fault terminal 006: Auto-restart 007: Momentary power loss 008: Emergency Stop(E.S.) 009: Base Block(b.b.) 010: Motor overload protection 011: Inverter overload protection 012: retain 013: Power ON 014: Communication error 015:Output current detection(>F26) | 005 | |
| 47 | Remote keypad control selection | 000:Disable (no wire break detection) 001: Enable. On wire break Stop according to F09 002: Enable. Runs at the last set frequency. On wire break Stop is according to F04 or Stop key on keypad. | 000 | Stop inverter then connect remote keypad for proper operation *4 |
| 48 | Copy module | 000: Copy module disable 001: copy to module from inverter 002: copy to inverter from module 003: read/ write check | 000 | *3 |
| 49 | Inverter communication address | 001 ~ 254 | 001 | *3 *4 |
| 50 | Baud rate (bps) | 000: 4800 001: 9600 002: 9200 003: 38400 | 003 | *3 *4 |
| 51 | Stop bit | 000: 1 Stop bit 001: 2 Stop bit | 000 | *3 *4 |
| 52 | Parity bit | 000: No parity 001: Even parity 002: Odd parity | 000 | *3 *4 |
| 53 | Data bits | 000: 8 bits data 001: 7 bits data | 000 | *3 *4 |
| 54 | Communication error detection time | 00.0 ~ 25.5 Sec | 00.0 | *3*5 |
| 55 | Communication error operation selection | 000: Deceleration to stop. (F02 : Deceleration time 1). 001: Free run to stop. 002: Deceleration to stop. (C12 : Deceleration time 2). 003: continue operating. | 000 | *3*5 |

Note: *1: Can be modified in Run mode.

***2: Frequency resolution is 1Hz for settings above 100 Hz.**

***3: Cannot be modified during communication.**

***4: Do not change while making factory setting.**

F52 factory setting is 020(60HZ) and motor parameter value is 170.

F52 factory setting is 010(50HZ) and motor parameter value is 140.

***5: Software version 1.2 later**

4.3 Parameter function description

Basic function parameter list

F00 Inverter horse power code

| F00 | Inverter model | |
|-----|----------------|-----|
| 1P2 | JNEV | 1P2 |
| 1P5 | | 1P5 |
| 101 | | 101 |
| 2P2 | | 2P2 |
| 2P5 | | 2P5 |
| 201 | | 201 |
| 202 | | 202 |

| F00 | Inverter model | |
|-----|----------------|-----|
| 203 | JNEV | 203 |
| 401 | | 401 |
| 402 | | 402 |
| 403 | | 403 |

F01 Acceleration time 1 (s): 00.1 – 999

F02 Deceleration time 1 (s): 00.1 – 999

Formula for acceleration/deceleration time: Denominator is based on (factory setting is Sensor less vector control)

- a) Motor rating frequency (Sensor less vector control). (C22=000)
 b) Max output frequency (V/f mode). (C22=001)

a)

$$\text{Acceleration time} = F01 \times \frac{\text{Set frequency}}{F45(\text{rated frequency})} \quad \text{Deceleration time} = F02 \times \frac{\text{Set frequency}}{F45(\text{rated frequency})} \rightarrow \text{vector}$$

b)

$$\text{Acceleration time} = F01 \times \frac{\text{Set frequency}}{C17(\text{Max output frequency})} \quad \text{Deceleration time} = F02 \times \frac{\text{Set frequency}}{C17(\text{Max output frequency})} \rightarrow \text{V/F}$$

F03 Motor rotating direction 000: Forward

001: Reverse

Only when F04 =000, inverter operation is controlled by keypad, such parameter is available.

F04 Run signal

000: keypad

001: External Terminal

002: Communication Control

- 1.) F04=000, inverter is controlled by keypad.
- 2.) F04=001, inverter is controlled by external terminal.
- 3.) F04=002, inverter is controlled by communication.

F05 Frequency signal

000: UP/Down Key on keypad

001: VR on keypad

002: TM2 input signal

003: Multi-function input terminal UP/DOWN function

004: Frequency set by communication method

(When C47=1, Remote Keypad plugs, it has the priority)

- 1.) F5=001, when one of parameter group F11~ F15 is set to 015 and multi-function input terminal is OFF, the frequency is set by VR on Keypad. If the multi-function input terminal is ON, the frequency is set by analog signal (auxiliary speed) from TM2.

- 2.) F5=002,when one of parameter group F11~ F15 is set to 015 and multi-function input terminal is OFF, the frequency is set by analog signal (auxiliary speed) from TM2. If the multi-function input terminal ON, the frequency is set by VR on Keypad.
- 3.) Up/Down terminal: please refer to description of parameter group F11~ F15(multi-function input terminal).
- 4.) Priority of reading frequency command: Jog> preset frequency > (Keypad▲▼ or TM2 UP/Down or communication)

| | |
|--|---|
| F06 : External control operation mode | 000: Forward/ Stop-Reverse/Stop 001: Run/ Stop-Forward/Reverse 002: 3-wire—Run/ Stop |
|--|---|

- 1.) F06 is only available when When F04 = 001 (external terminal).
- 2.) When both forward and reverse commands are ON, it will be take into Stop.

Parameter F06 = 000, Control method is as following:

(1). NPN input signal:

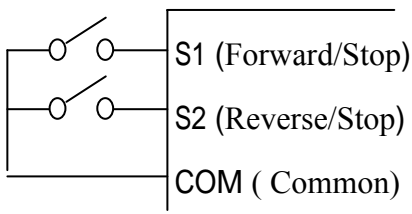

(2). PNP input signal:

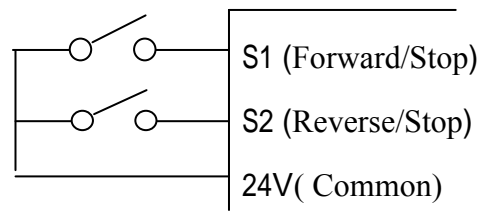

Parameter F06 = 001, Control method is as following:

(1). NPN input signal:

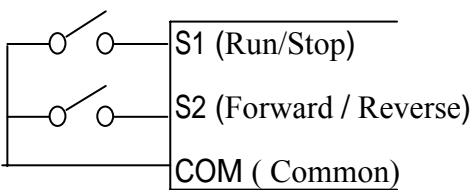

(2). PNP input signal:

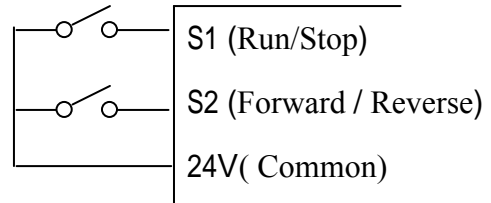

Parameter F06 = 002, Control method is as following:

(1). NPN input signal:

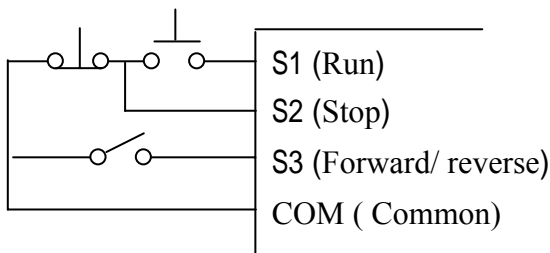

(2). PNP input signal:

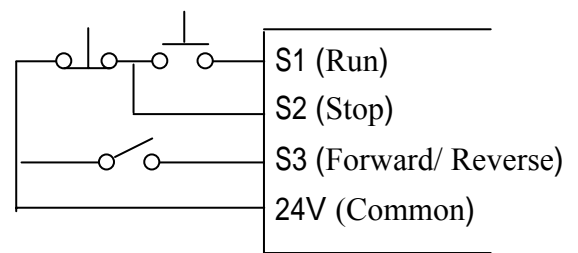

Note: - In 3 wire control mode terminals S1-S3 are used , therefore Parameters F11~ F13 are ineffective.

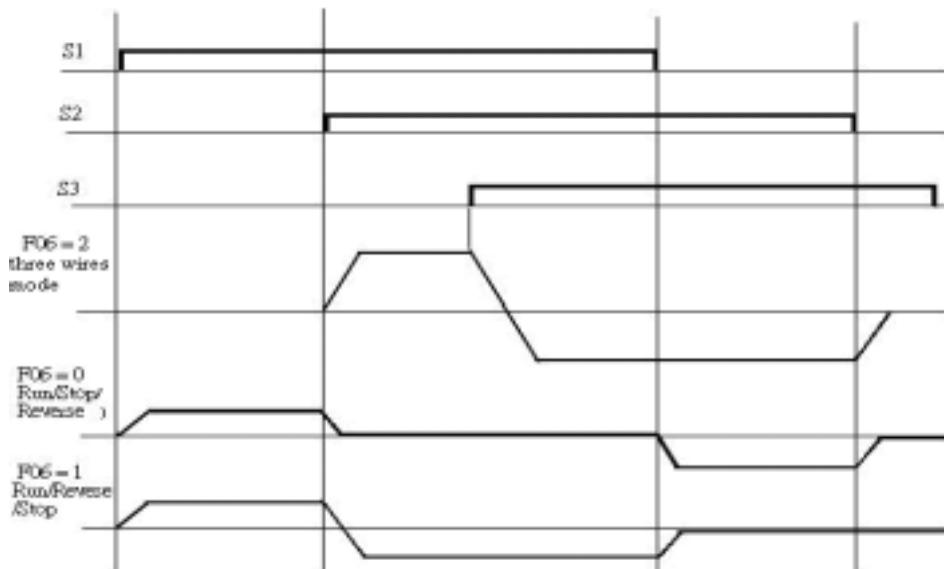

Note: C00=001, reverse command is disable.

F07 Frequency upper limit (Hz) : 01.0 - 200

F08 Frequency lower limit (Hz): 00.0 - 200

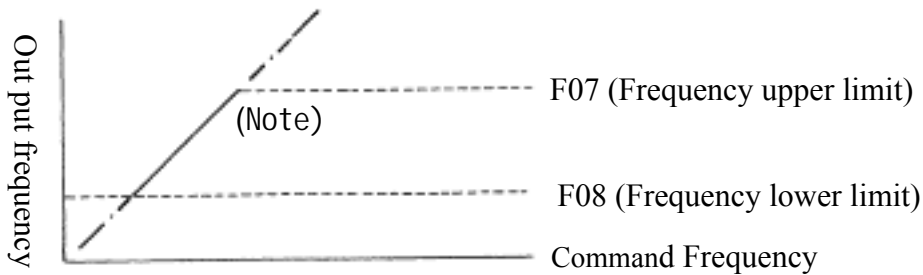

Note: If F07 = 0 Hz and frequency command = 0 Hz, the inverter will 0-speed stop.

If F08 > 0 Hz and frequency command = F08, inverter output at F08 set value.

| | |
|----------------------------|---------------------------------------|
| F09 Stopping method | 000: Decelerate to stop |
| | 001: Free run (Coast) to stop |

- 1.) F09 = 000: after receiving stop command, the motor will decelerate to stop according to setting of F02.
- 2.) F09 = 001: after receiving stop command, the motor will free-run (Coast) to stop.

| | |
|--------------------------------------|---------------------|
| F10 Status monitoring display | 000: Disable |
| | 001: Enable. |

F10 = 001 displays motor current, voltage and DC link voltage, PID feedback.

| | |
|---------------|--|
| F11~15 | Selectable Functions for input terminals (S1-S4& AIN) 000: Forward Run 001: Reverse Run 002: Preset Speed Command 1 003: Preset Speed Command 2 004: Preset Speed Command 3 005: Jog frequency Command 006: Emergency stop(E.S.) 007: Base Block (b.b.) 008: Switching to 2nd acceleration/ deceleration time 009: Reset 010: Up command 011: Down command 012: Control signal switch 013: Communication mode. Disable – Enable. 014: Acceleration/deceleration prohibit 015: Master/Auxiliary speed switch 016: PID function prohibit 017: Analog frequency signal input (terminal AIN) 018: PID feedback signal (terminal AIN) |
|---------------|--|

1.) S1-AIN on TM2 are multi-function input terminals which can be set above 19 functions.

2.) F11~F15 function description:

F11~F15=000/001(Forward/ Reverse)

Forward command ON means inverter running forward, While OFF, the inverter stops. F11 factory default is forward command.

Reverse command ON means inverter running reverse, While OFF, the inverter stops. F12 factory default is reverse command.

If forward –reverse command are ON at the same time it is considered as Stop.

F11~F15=002~004(Preset Speed Command 1~3)

When run signal is applied and the selected external multi-function input terminal is on, the inverter will run at one of 8 preset speeds which are controlled by the status of the terminals. The corresponding speeds are as that programmed in parameters F28 to F36 as shown in the table below.

F11~F15=005(Jog Frequency Command)

When run signal is applied and the selected external multi-function input terminal is on and set to Jog speed, the inverter will run according to F36.

Priority of the frequency: Jog > preset speed

| Preset Speed Command 3 Set value=004 | Preset Speed Command 2 Set value=003 | Preset Speed Command 1 Set value=002 | Jog Frequency Command Set value=005 | Output frequency set value |
|---|---|---|--|----------------------------|
| X | X | X | 1 | F36 |
| 0 | 0 | 0 | 0 | F28 |
| 0 | 0 | 1 | 0 | F29 |
| 0 | 1 | 0 | 0 | F30 |
| 0 | 1 | 1 | 0 | F31 |
| 1 | 0 | 0 | 0 | F32 |
| 1 | 0 | 1 | 0 | F33 |
| 1 | 1 | 0 | 0 | F34 |
| 1 | 1 | 1 | 0 | F35 |

F11~F15=006: Emergency Stop(E.S)

The inverter will decelerate to stop on receiving the external emergency stop signal.

The display will be blinking with E.S.

The inverter will only start again when the Emergency Stop signal is removed and the start signal is turned off and then on again (remote start mode) or the Run key is pressed in (keypad mode).

Removing the Emergency Stop signal before the inverter has fully stopped will not inhibit the Emergency Stop operation.

Output relay can be set to Emergency, Stop fault by setting F21=008

F11~F15=007: Base Block (b.b.)

The inverter will stop immediately on receiving Base Block signal regardless of setting of F09 and blink b.b. The inverter will auto restart at speed search as Base Block signal released.

F11~F15=008: Switching to 2nd acceleration/ deceleration time

When external terminal is ON it selects the 2nd acceleration/ deceleration time

F11~F15=009 : Reset command

Reset command ON . The inverter will be disabled. Resettable faults will be cleared.

F11~F15=010/011 : UP / DOWN function: (According to acceleration/deceleration time)

Set F05=003, to enable UP/DOWN function, and the UP/DOWN key on Keypad is unavailable for changing frequency directly.

Set C40=000, When UP/DOWN terminal is ON, the inverter begins to accelerate/ decelerate, to a frequency and stops to accelerate/ decelerate when the UP/ DOWN signal has been released and runs at the reached speed.

The inverter will decelerate to stop or free run to stop when run command is OFF according to F09. The speed at which the inverter stops will be stored in F28.

UP/DOWN key is now unavailable for modifying frequency. It should be modified F28 by Keypad.

Set C40=001, The inverter will run from 0Hz on receiving run command.

UP/DOWN action is similar to above description. When the run command is released, the inverter will decelerate to stop or free run to stop (0 Hz) according to setting of F09.

The inverter will output from 0Hz in next operation.

Note: UP/ DOWN commands are disabled if both terminals are ON at the same time.

F11~F15=012: Control signal switch

External control terminal OFF: operation signal/ frequency signal is controlled by F04/F05.

External control terminal ON: Operation signal/frequency signal is controlled by Keypad (which is not controlled by F04/F05).

F11~F15=013: Communication mode select.

External control terminal OFF: in communication, the inverter is controlled by master (PC or PLC) run/ frequency signal and allowed to modify the parameter. The Keypad and TM2 run/frequency signal is not available for inverter at this time. The keypad is only available for display voltage/ current/ frequency and read parameter but not modify it. What is more, it is available for emergent stop.

External control terminal ON: PC/PLC can read and modify parameters. BUT all controls are from keypad. (not effected by setting of F04 & F05)..

F11~F15=014: Acceleration/deceleration Disable.

When external control terminal ON, the inverter will stop accelerating/ decelerating till the signal is released. The motion is as following:

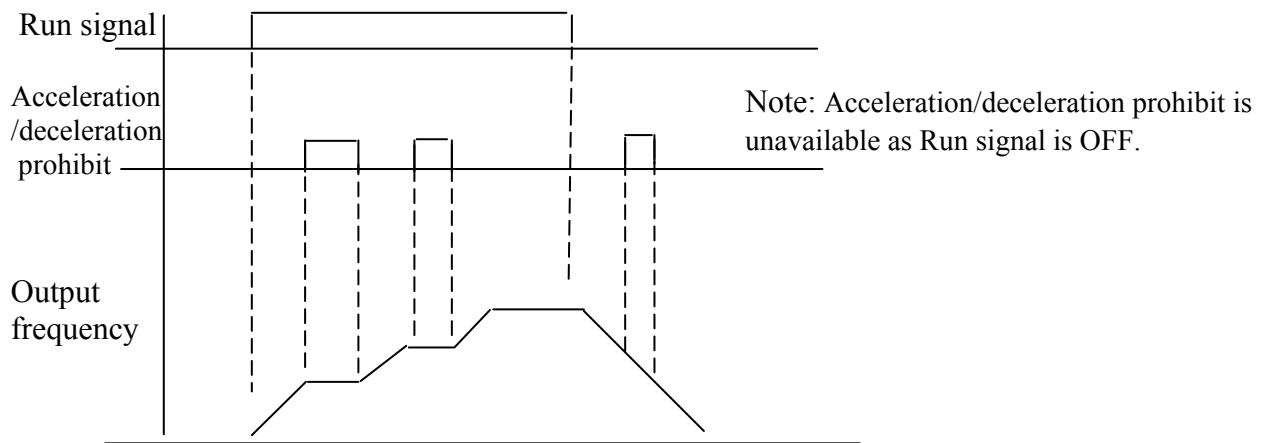

F11~F15=015 Master/Auxiliary speed switch

- 1) F05=001 , when one of the parameters F11~ F15 is set to 015, and multi-function input terminal is OFF, the frequency is set by the VR on the Keypad(Master speed); When multi-function input terminal is ON, the frequency is set by the analog signal on TM2 (Auxiliary speed AIN).
- 2.) F05=002 , when one of the parameters F11~ F15 is set to 015, and multi-function input terminal is OFF, the frequency is set by the analog signal on TM2, (Master Auxiliary speed AIN); While multi-function input terminal is ON, the frequency is set by the VR on the Keypad (Auxiliary speed).

F11~F15=016 (PID function Disable)

When input terminal is on, PID functions set by C30 are disabled.
When it is off it enables the PID functions.

F15=017 Analog frequency signal input (Terminal AIN)

Frequency reference can be set by 0-10Vdc or 4-20mA on terminal AIN as set by F16 and SW2.

F15=018 PID Feedback signal input (Terminal AIN)

PID feedback can be connected to AIN terminal 0-10Vdc/0~20mA or 2~10V/4-20mA as set by F16 and SW2.

F16 AIN signal select

000: 0~10V/0~20mA

001: 2~10V/4~20mA

F16: **AIN signal select:** collocation SW2 to V/I signal select

F16=000: 0~10V/0~20mA

F16=001: 2~10V/4~20mA

F17 AIN Gain (%) 000 - 200

F18 AIN Bias (%) 000 - 100

- 1.) F19= 000: 0V (4mA) corresponding to lower frequency limit, 10V (20mA) corresponding to upper frequency limit.
- 2.) F19= 001: 10V (20mA) corresponding to lower frequency limit, 0V (4mA) corresponding to upper frequency limit.

Fig (1) setting:

| | F17 | F18 | F19 | F20 |
|---|-------|------|-----|-----|
| A | 100 % | 050% | 000 | 000 |
| B | 100 % | 000% | 000 | 000 |

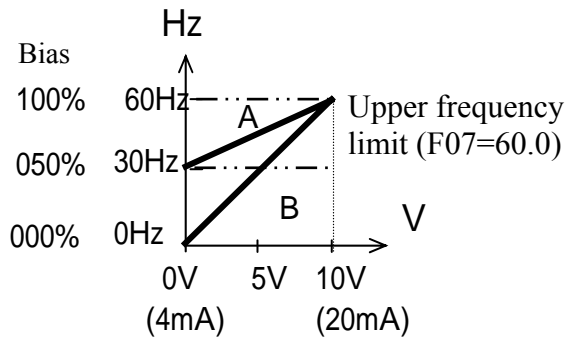

Fig (1)

Fig (2) setting:

| | F17 | F18 | F19 | F20 |
|---|-------|------|-----|-----|
| C | 100 % | 050% | 000 | 001 |
| D | 100 % | 000% | 000 | 001 |

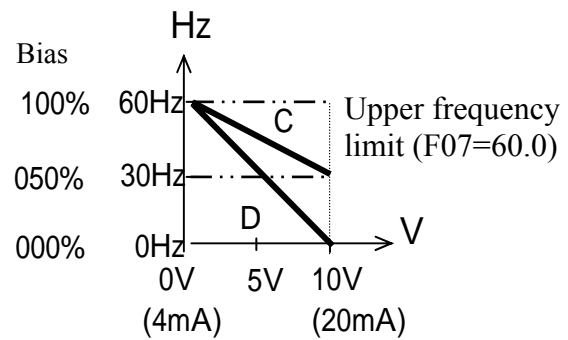

Fig (2)

Fig (3) setting:

| | F17 | F18 | F19 | F20 |
|---|-------|------|-----|-----|
| E | 100 % | 020% | 001 | 000 |

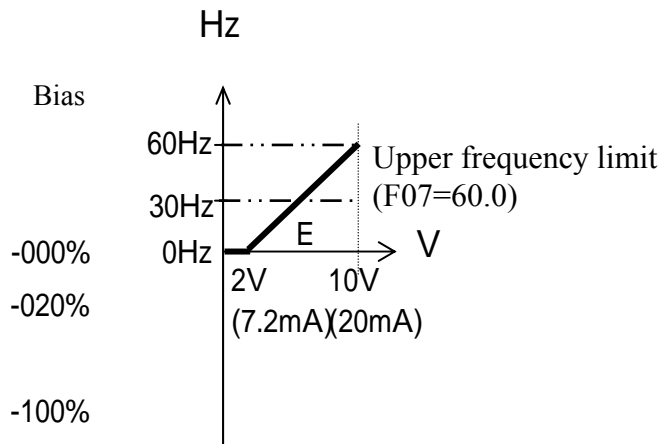

Fig (3)

Fig (4) setting:

| | F17 | F18 | F19 | F20 |
|---|-------|------|-----|-----|
| F | 100 % | 050% | 001 | 001 |

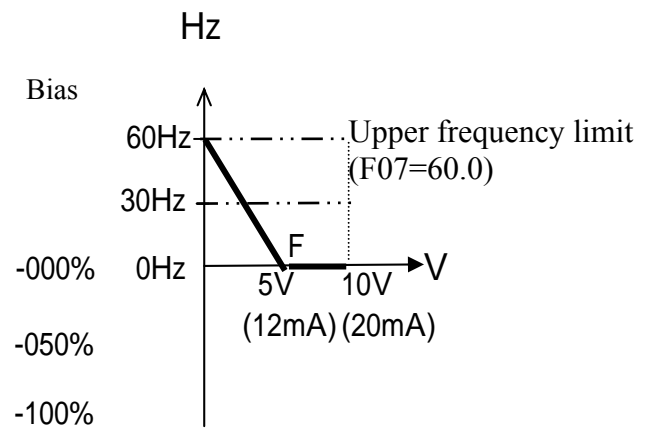

Fig (4)

F19 AIN Bias: 000: Positive 001: Negative
F20 AIN Signal Slope direction. 000: Positive 001: Negative
C45 AIN signal scan time confirmation. (mSec × 8): 001 – 100

Refer to F17/F18 description

The inverter reads A/D average value every $C45 \times 8\text{mS}$. The user can set scan interval time according to noise in the operation environment. Extend C45 if noise is a problem, while the response speed will be slow.

F21 Multi function output RY1

000: In running
 001: Frequency reached (Preset target frequency $\pm F23$)
 002: Frequency reached (Preset output frequency level (F22) $\pm F23$)
 003: Frequency Detection ($>F22$)
 004: Frequency Detection ($<F22$)
 005: Fault output
 006: Auto restart
 007: Momentary power loss
 008: Emergency Stop(E.S.)
 009: Base Block(b.b.)
 010: Motor overload protection
 011: Inverter overload protection
 012: retain
 013: Power On
 014: Communication error
 015: Output current detection

F22 Preset Output frequency reached =00.0 ~ 200Hz

F23 Frequency detection range =00.0 ~ 30Hz

F21/C46=001: reach frequency (Target frequency $\pm F23$)

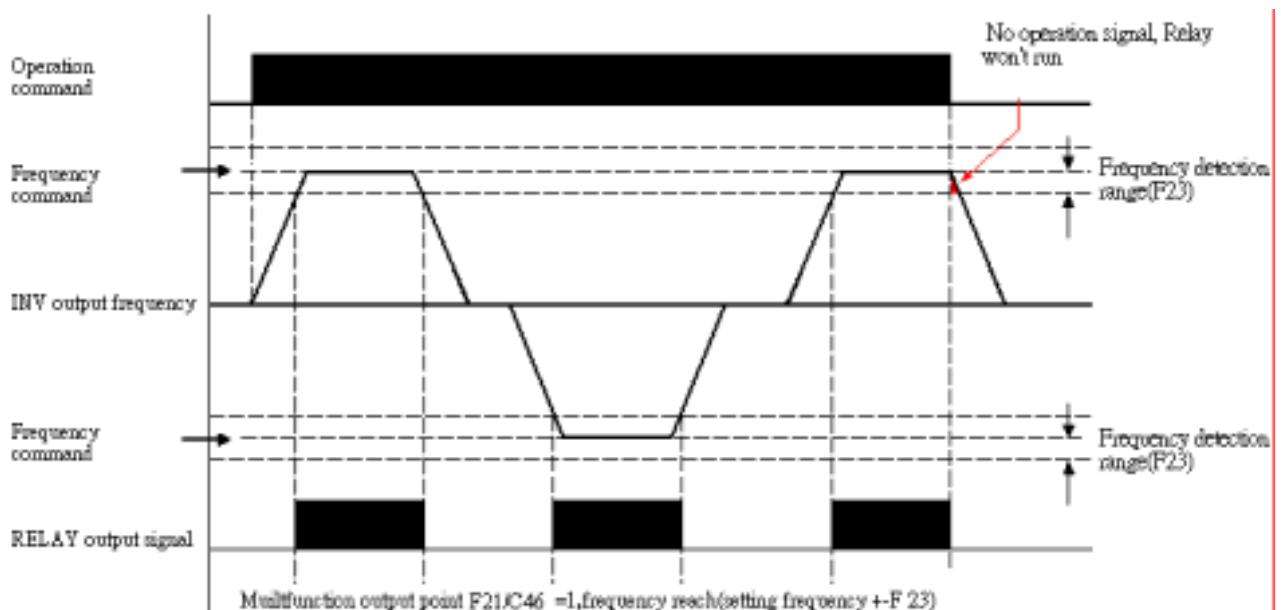

F21/C46=002 Preset output Frequency F22 ± F23 reached.

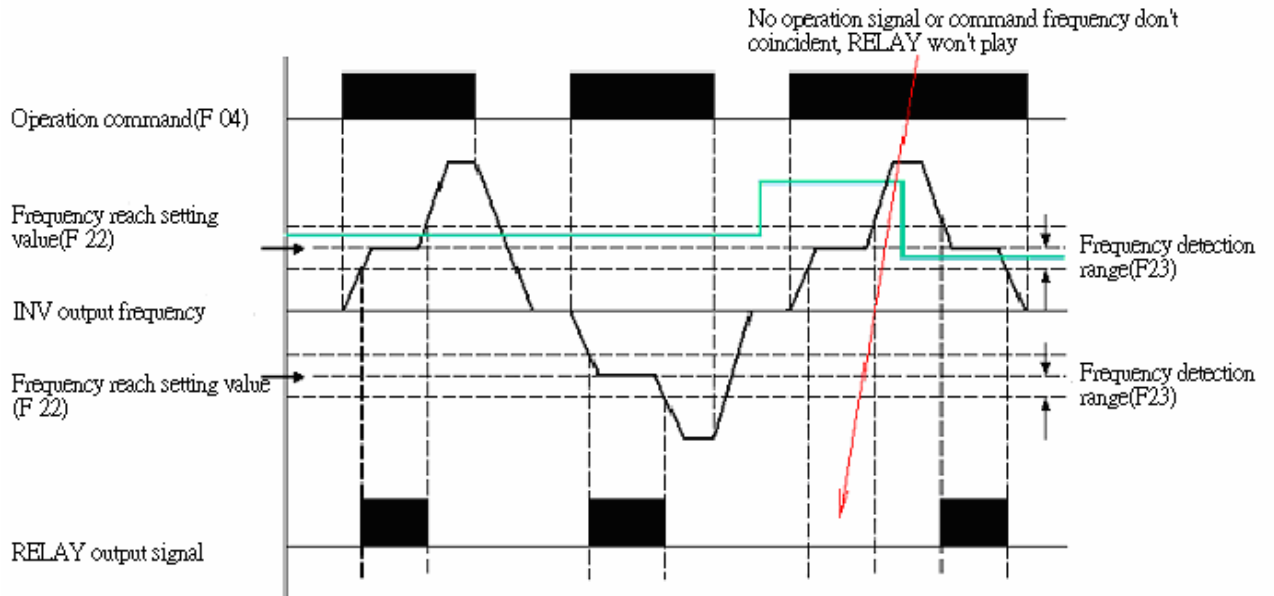

F21/C46=003: Frequency detection Fout>F22

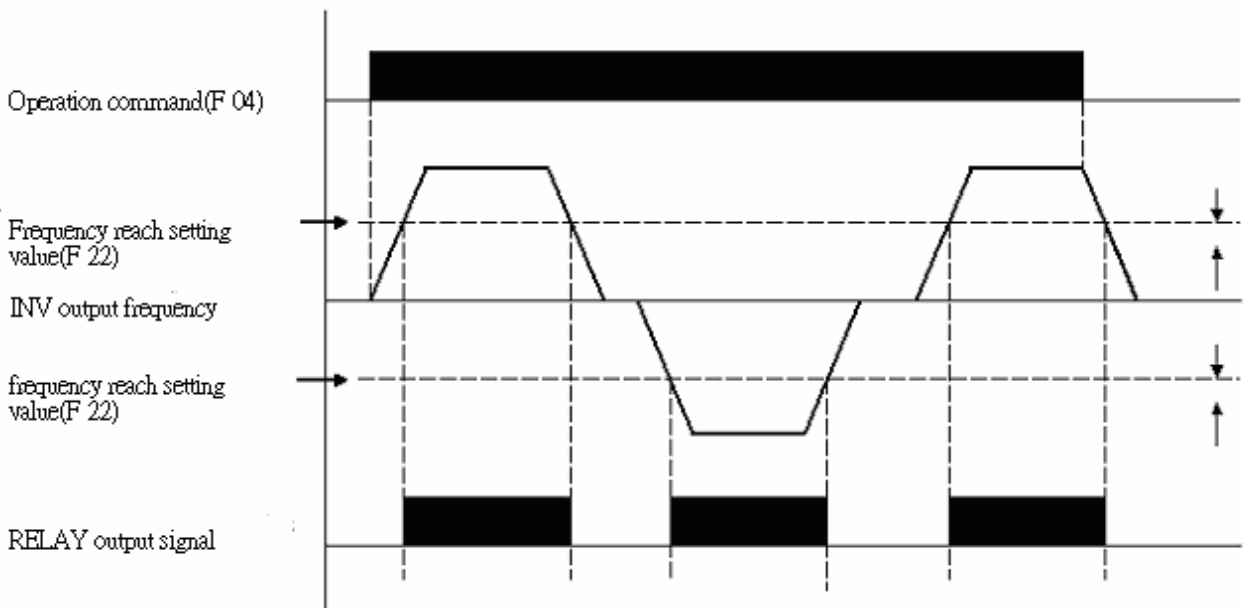

F21/C46=004: Frequency detection $F_{out} < F_{22}$

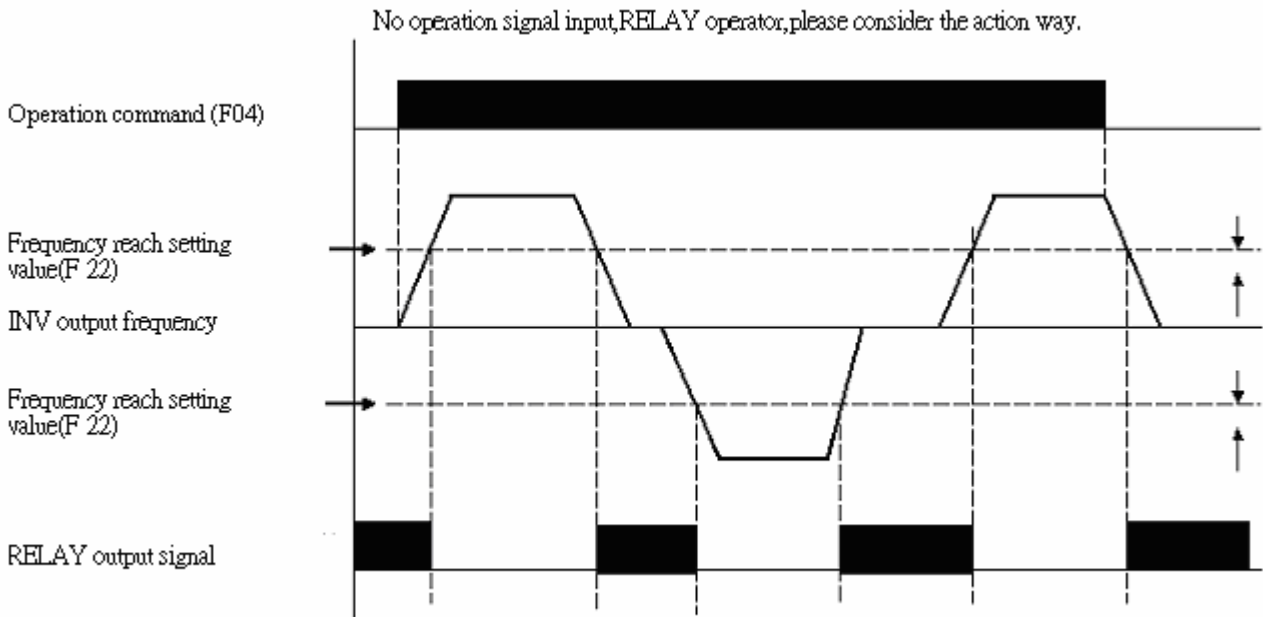

F24 Output current reach setting value

F25 Output current detection time

- F21: Output current detection value $> F_{24}$
- C46: Output current detection value $> F_{24}$ When setting value is 015
- F24: Setting value (000~100%) by motor rated current (F43)
- F25: Setting value (00.0~25.5) unit : sec

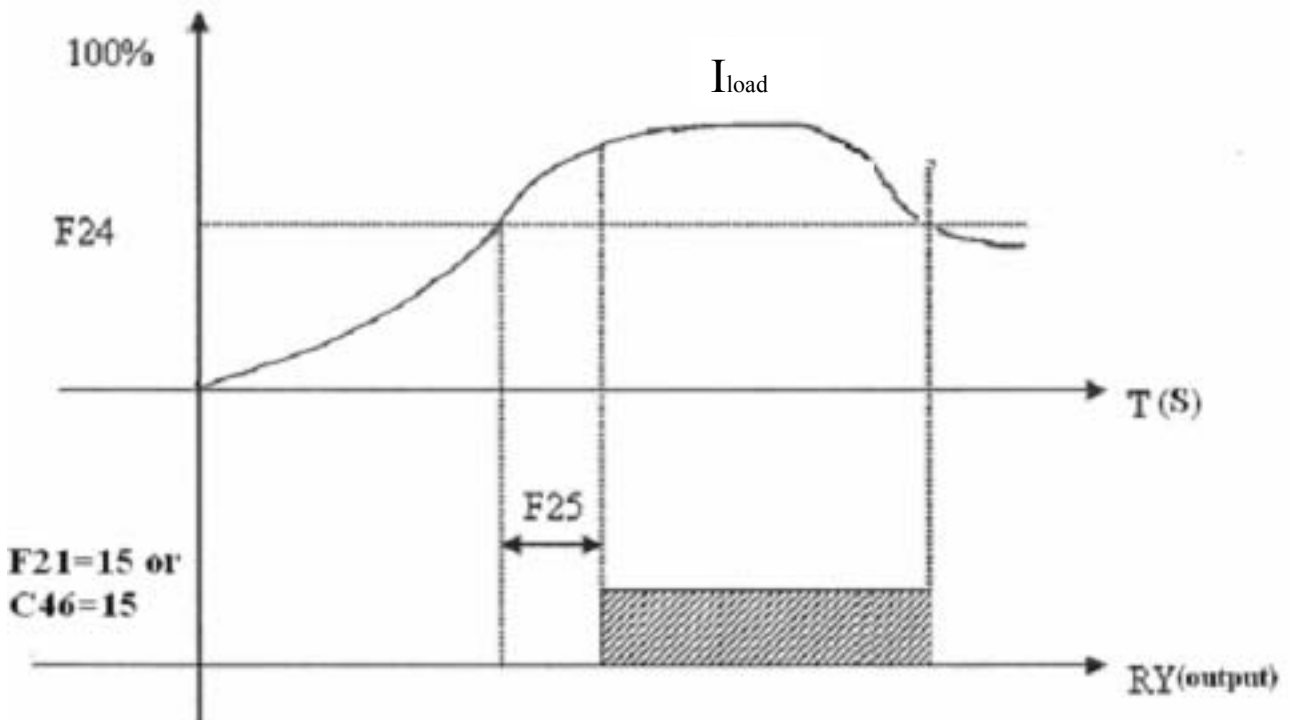

Multi-function analog output:**F26 Multi-function output analog type selection****001: Set frequency****002: Output frequency****003: DC voltage****004: Output current****005:PID feedback signal****F27 Multi-function analog output gain = 000 ~ 200%**

0-10 Vdc output from FM+ multi-function analog output terminal.

Output can be set to any of the above selections.

F27 is used to scale the output signal supplied to the externally connected analog device.

F26=005, PID Feedback. The analog input to terminal AIN (0-10vdc or 4-20mA),will be output from terminal FM+ as 0-10Vdc.

Note: Due to hardware limits, the max output voltage from FM+ terminal will be limited to 10V.

Keypad, jog and preset frequency setting (MFIT) :

Note1 :- Frequency selection will be made according to the setting of terminals S1-S4 & AIN and also setting of parameters F11 – F15 as required.

Note2:- Selected preset frequency values should be programmed in parameters F28- F36 as required.

1) F11~F15=002-004 (Preset frequency Command 1~3)

When run signal is applied and any of the selected multi-function input terminals is ON, the inverter will run at the preset frequency according to the table below.

2) F11~F15=005 (Jog Frequency Command)

External input terminal is set to Jog operation. As it is on, the inverter will run at Jog frequency.

| Parameter | Description | Frequency range | Factory default |
|-----------|-------------------------|-----------------|-----------------|
| F28 | Preset frequency 1 (Hz) | 00.0 - 200 | 05.0 |
| F29 | Preset frequency 2 (Hz) | 00.0 - 200 | 05.0 |
| F30 | Preset frequency 3 (Hz) | 00.0 - 200 | 10.0 |
| F31 | Preset frequency 4 (Hz) | 00.0 - 200 | 20.0 |
| F32 | Preset frequency 5 (Hz) | 00.0 - 200 | 30.0 |
| F33 | Preset frequency 6 (Hz) | 00.0 - 200 | 40.0 |
| F34 | Preset frequency 7 (Hz) | 00.0 - 200 | 50.0 |
| F35 | Preset frequency 8 (Hz) | 00.0 - 200 | 60.0 |
| F36 | Jog frequency (Hz) | 00.0 - 200 | 05.0 |

Frequency read priority: Jog → Preset frequency → External analog frequency signal

| Preset Frequency Command 3 Set value =004 | Preset Frequency Command 2 Set value =003 | Preset Frequency Command 1 Set value =002 | Jog frequency Command Set value =005 | Output frequency |
|--|--|--|---|------------------|
| 0 | 0 | 0 | 0 | F28 |
| 0 | 0 | 1 | 0 | F29 |
| 0 | 1 | 0 | 0 | F30 |
| 0 | 1 | 1 | 0 | F31 |
| 1 | 0 | 0 | 0 | F32 |
| 1 | 0 | 1 | 0 | F33 |
| 1 | 1 | 0 | 0 | F34 |
| 1 | 1 | 1 | 0 | F35 |
| X | X | X | 1 | F36 |

F37 DC braking time (s) : 00.0~25.5

F38 DC braking start frequency (Hz) : 01.0~10.0

F39 DC braking level (%) : 00.0~20.0%

F37 / F38: DC braking time and start frequency, as following figure:

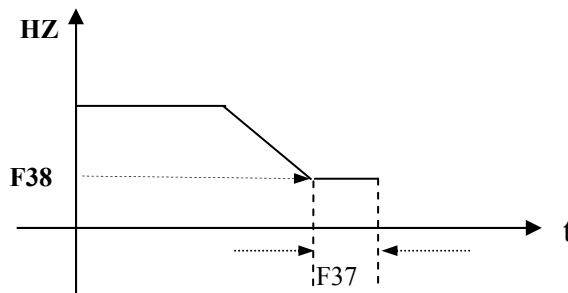

F40 Carrier frequency (KHz) : 004-016

Set this parameter to a level from 4-16KHz as required. (Default is 10 KHz).

Note: In situations where there is excessive vibration noise from the motor or it is required to reduce electrical interference from the inverter caused by use of long cable then the carrier frequency can be adjusted as follows:-

- To reduce interference due to long cable decrease carrier frequency.
- To reduce motor increase carrier frequency. If so then the output current from the inverter will be de-rated according to the following table.

| | | | | | | | |
|-----|-------------------|-----|-------------------|-----|-------------------|-----|-------------------|
| F40 | Carrier frequency | F40 | Carrier frequency | F40 | Carrier frequency | F40 | Carrier frequency |
| 004 | 4KHz | 008 | 8KHz | 012 | 12KHz | 016 | 16KHz |
| 005 | 5KHz | 009 | 9KHz | 013 | 13KHz | | |
| 006 | 6KHz | 010 | 10KHz | 014 | 14KHz | | |
| 007 | 7KHz | 011 | 11KHz | 015 | 15KHz | | |

Corresponding list of current and carrier frequency

| Model Carrier frequency | EV-1P2/2P2 H1/H1F/H3 | EV-1P5/2P5 H1/H1F/H3 | EV-101/201 H1/H1F/H3 | EV-202 H1/H1F/H3 | EV-203 H1/H1F/H3 | EV-401 H3/H3F | EV-402 H3/H3F | EV-403 H3/H3F |
|----------------------------|-------------------------|-------------------------|-------------------------|---------------------|---------------------|------------------|------------------|------------------|
| 4~10K | 1.7 | 3.1 | 4.2 | 7.5 | 10.5 | 2.3 | 3.8 | 5.2 |
| 12K | 1.7 | 3.1 | 4.2 | 7.5 | 10.5 | | | |
| 14K | 1.6 | 3.0 | 4.0 | 7.0 | 10 | | | |
| 16K | 1.5 | 2.8 | 3.8 | 6.8 | 9.8 | | | |

F41 Auto restart on momentary power loss. 000: Enable
001: Disable

F41=000: Auto restart after a momentary power loss is enabled on resumption of power and application of run signal, according to setting of parameter F4.

The Inverter will carry out an auto speed search, once the motor spinning speed is found then it will accelerate to the running speed before the power loss.

F41=001: Disable.

F42 Auto restart times: 000 ~ 005

1.) F42=000: The inverter will not auto-restarted on fault trip.

2.) F42>000

The Inverter will carry out an auto search 0.5 sec after the fault trip, and while the inverter output is switched off and the motor is coasting to stop.

Once the spinning speed is determined the inverter will accelerate or decelerate to speed before the fault.

3.) Auto restart is not include OL1, OL2, OH, BB, warning.

Note:- Auto restart will not function while DC injection breaking or deceleration to stop Is performed.

F43 Motor rated current (A)
F44 Motor rated voltage (Vac)
F45 Motor rated frequency (Hz)
F46 Motor rated power (KW)
F47 Motor rated speed (RPM)

F48 Torque boost gain (Vector), C14=000

Performance: If detection the motor load is too large increase the output torque.

$$T_e = I \times \text{Gain}$$

(load current) (compensation gain)

- Torque/Speed curve pattern:

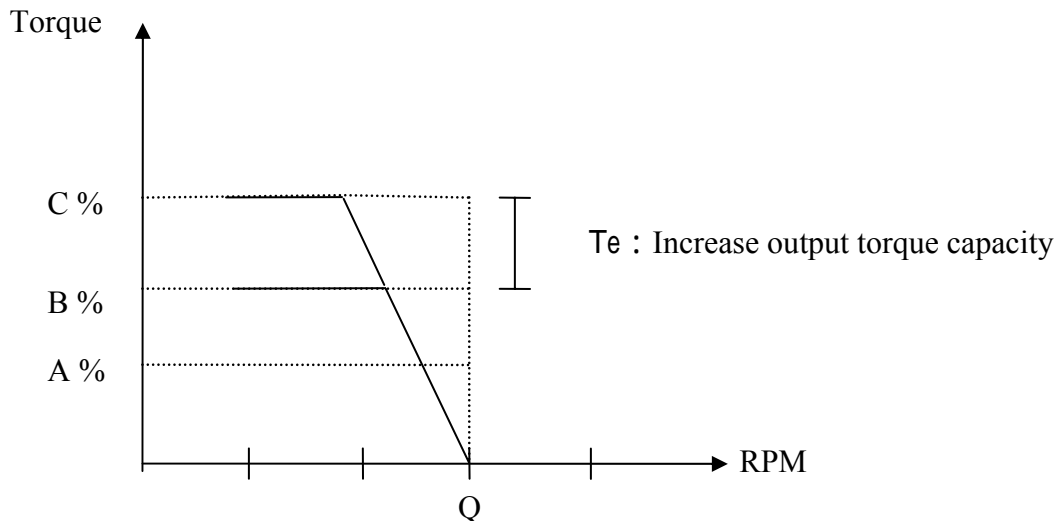

- Operating frequency range: 0~Motor rate frequency
- When the motor output torque is not enough and increase F48 setting value.
- When the motor is vibration or tremble and decrease F48 setting value.
- The max. output torque limit to the inverter current rated.
- If increase F48 setting value then the output current is too large. Please increase C49 setting value on the same time.

F49 Slip compensation gain (vector), C14=000

Performance: If detection the motor load is too large and increase slip compensation.

$$F_{\text{slip}} = I \times \text{Gain}$$

(load current) (compensation gain)

- Torque/Speed curve pattern:

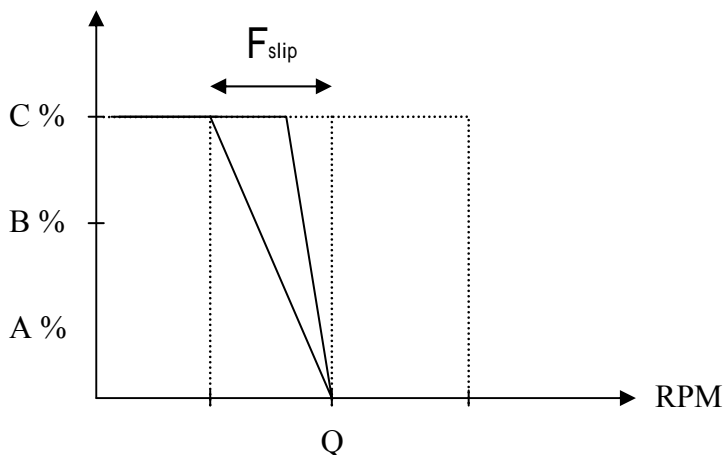

- Operating frequency range: 0~motor rated frequency.
- When the motor output rotate speed is too low and increase F49 setting value.
- When the motor is vibration or tremble and decrease F48 setting value.
- The max. output rotate speed limit to the motor max. setting frequency.
- If increase F49 setting value then the output current is too large. Please increase C48 setting value on the same time.

F50 Low frequency voltage compensation, C14=000

Performance: During low frequency

Increase F50 setting value can increase output voltage and low frequency torque.

Decrease F50 setting value can decrease output voltage and low frequency torque.

- Output voltage/frequency curve pattern:

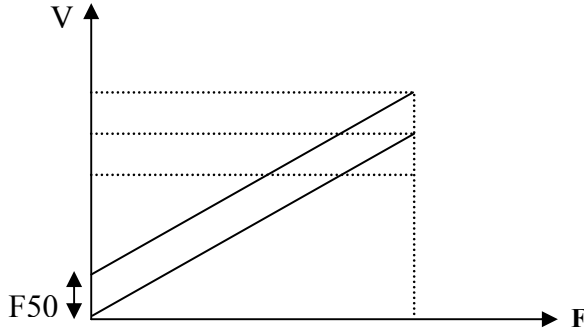

- Operating frequency range: 0~12HZ / 60HZ
0~10HZ / 50HZ

- During low frequency use:

When the motor output torque is not enough and increase F50 setting value.

When the motor is vibration and decrease F50 setting value.

| | |
|--|---|
| F51 Advanced parameter function display | 000:Disable access to advanced parameters (Group C) 001:Enable access to advanced parameters (Group C) |
|--|---|

F51=000. Parameter group C can not be displayed or accessed.

F51=001. Enable display and access parameter group C .

| | |
|----------------------------|--|
| F52 Factory default | 010: Reset parameters to factory default (50Hz) 020: Reset parameters to factory default (60Hz) |
|----------------------------|--|

| |
|-----------------------------|
| F53 Software version |
|-----------------------------|

| |
|---|
| F54 Fault records (Latest 3 times) |
|---|

Advanced Parameters List (Group C parameters)

| | |
|------------------------|---|
| C00 Reverse run | 000: Reverse enable 001: Reverse disable |
|------------------------|---|

F04=000 and C00=001, F03 (motor direction) disable, the inverter is set to forward operation.

F04=001 or 002, and C00=001, reverse command is disable.

| | |
|---|---|
| C01 Acceleration stall-prevention: | =000: Enable Stall prevention during Acceleration. |
| | =001: Disable Stall prevention during Acceleration. |
| C02 Acceleration stall-prevention level: 050% ~ 200% | |
| C03 Deceleration stall-prevention: | = 000: Enable Stall prevention during deceleration. |
| | = 001: Disable Stall prevention during deceleration. |
| C04 Deceleration stall-prevention level: 050% ~ 200% | |
| C05 Run stall-prevention: | = 000: Enable Stall prevention in Run mode. |
| | = 001: Disable Stall prevention in Run mode. |
| C06 Run stall-prevention level: 050% ~ 200% | |
| C07 stall prevention time during run mode. | = 000: according to F02 (Deceleration 1). |
| | = 001: according to C08. |
| C08 Stall prevention deceleration time: 00.1 ~ 999s | |

- 1.) When the Acceleration time is set too short the inverter could trip on Over Current (OC).
If the time can not be increased then can use trip prevention, a trip prevention level has to be programmed and when the inverter detects this level it holds the acceleration until the current is below the set level then it continues with acceleration.
- 2.) When the Deceleration time is set too short the inverter could trip on Over Voltage (OV).
If the time can not be increased then can use trip prevention, a trip prevention level has to be programmed and when the inverter detects this level it holds the deceleration until the voltage is below the set level then it continues with deceleration.
- 3.) The Inverter could trip (Stall) during run mode due to an impact load or sudden changes of the load.
Stall prevention in run mode will detect a programmed stall level (C06) for a period of time (C07) , if the level exceeds C06 , then inverter reduces its frequency (speed) to provide the required additional torque to overcome the stall,once this level is below the programmed stall level then it ramps up to its normal running speed.

| | |
|-------------------------------------|---|
| C09 Direct start on power up | 000: Enable direct start on power up. |
| | 001: Disable direct start on power up. |



Danger:

- 1.) C09=000 and external run mode (F04=001), the inverter will auto start as the power supplied to the inverter and if the RUN switch is in ON position.

This feature should only be considered when all safety implications of its use have been investigated. Risk assessment for maintenance, use of warning labels etc.

Our recommend option will be with this mode disabled.

- 2.) C09=001 and external run mode (F04=001), the inverter will not auto start as power supplied and the RUN switch is in ON position.
Inverter display will blink with SP1 error message. It can only restart after the RUN switch was turned off and ON again.

| | |
|-----------------------|--|
| C10 Reset mode | 000: Reset is enable when RUN switch is in OFF position. 001: Reset is enable with RUN switch, either OFF or ON . |
|-----------------------|--|

C10=000. Fault can not be reset, therefore inverter can not start. If the RUN switch is in ON position.
(F4=001)

| |
|--|
| C11 2nd acceleration time (s) : 00.1 – 999 C12 2nd deceleration time (s) : 00.1 – 999 |
|--|

| | |
|------------------------|--|
| C13 Fan control | 000: Auto-run by inverter temperature 001: Run when inverter running 002: Always run. 003: Always stop. |
|------------------------|--|

- 1.) C13=000: The fan will auto run as sensing certain temperature in order to extend the life span of the fan.
- 2.) C13=001: The fan runs as long as inverter is running.
- 3.) C13=002: The fan runs as long as power is supplied.
- 3.) C13=003: The fan does not run at any time.

| | |
|--|--------------------------------------|
| C14:Control mode | Vector control or V/F control |
| C17: Max. output frequency (HZ) | = 50.0 –200Hz |
| C18: Output voltage ratio in max. frequency (%) | = 00.0 – 100% |
| C19: Mid frequency (HZ) | = 00.1 – 200Hz |
| C20: Output voltage ratio in mid. frequency (%) | = 00.0 – 100% |
| C21: Min. output frequency (HZ) | = 00.1 – 200Hz |
| C22: Output voltage ratio in min. frequency (%) | = 00.0 – 100% |

C17~C22 please refer to C15 description

| |
|--|
| C15 : Preset V/F patterns = 1 – 7 |
|--|

C15 = 007. Selects user-set v/f pattern by setting parameters C17~C22 .

As shown in diagram below. Care should be taken when this feature is used as incorrect setting of these parameters will have a direct effect motor performance.

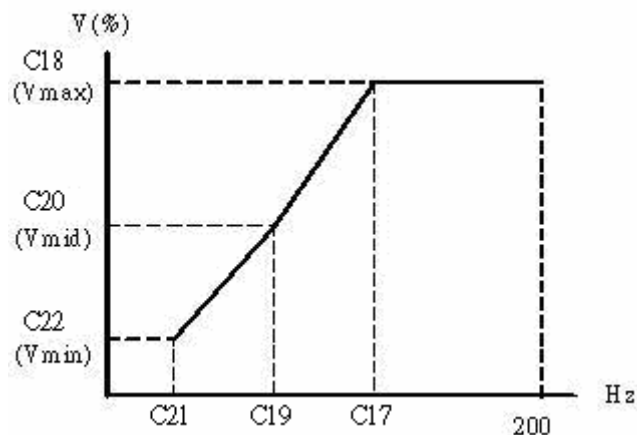

C15 = 001– 006 fixed V/F pattern (refer to following table).

| Spec | Purpose | C15 | V/F Pattern | Spec | Purpose | C15 | V/F Pattern |
|--------------|-------------------|-----|-------------|--------------|-------------------|-----|-------------|
| 50 Hz System | General | 001 | | 60 Hz System | General | 004 | |
| | High start torque | 002 | | | High start torque | 005 | |
| | Variable torque | 003 | | | Variable torque | 006 | |

C16 VF base output voltage set

As C17=60HZ
 C18=100%

If C16 setting 200~240V, then output voltage for the pattern:

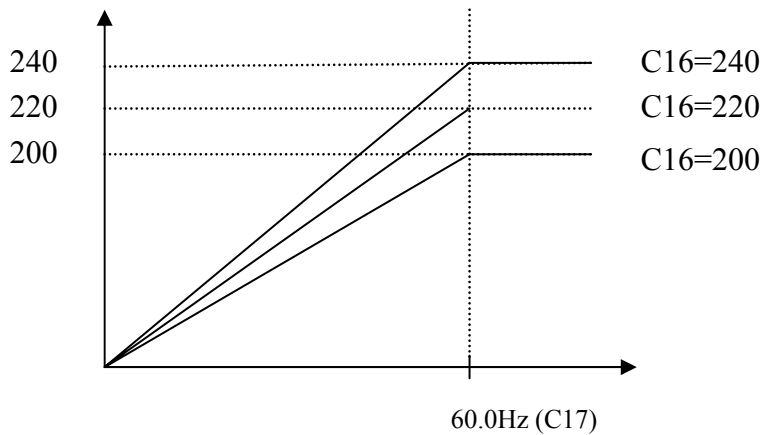

When the output voltage is higher than the input voltage and the max. output voltage limit to the max. input voltage.

C23 Torque Boost Gain (V/F) (%) 00.0 – 30.0%

C24 Slip Compensation Gain (V/F) (%) 00.0 – 100%

C25 Motor no load current (A)

Motor no load current differs with inverter capacity F00. Please adjust it according the actual condition.

C26 Electronic thermistor protection for motor (OL1) :
000: Protection Enabled
001: Protection Disabled

- C27 Skip frequency 1 (Hz) : 00.0 –200**
- C28 Skip frequency 2 (Hz) : 00.0 –200**
- C29 Skip frequency range (± Hz) : 00.0 –30.0**

Example: When C27=10.0Hz/C28=20.0Hz / C29=02.0Hz

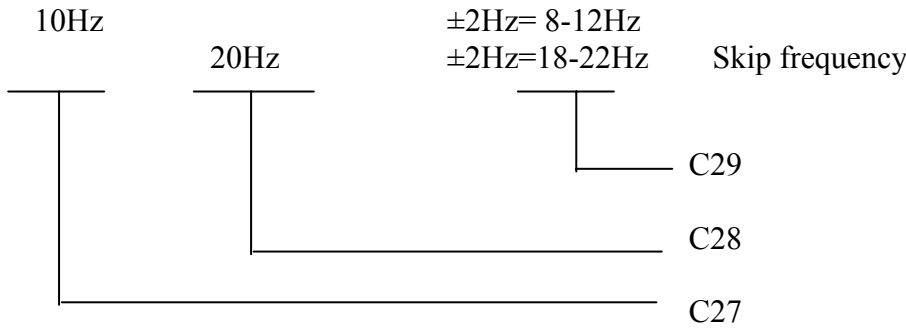

C30 PID operation mode**000: PID Function disabled.****001: PID Control, Deviation is derivative controlled****002: PID Control, Feedback id derivative controlled.****003: Same as 001 but (reverse characteristics control).****004: Same as 002 but (reverse characteristics control).**

C30 =1, D is the deviation of (target value – feedback value) in the unit time (C34).

=2, D is the deviation of feedback value in the unit time (C34).

=3, D is the deviation of (target value – feedback value) in the unit time (C34). If the deviation is positive, the output frequency decreases, vice versa.

= 4, D is the deviation of feedback value in unit time (C34). When the deviation is positive, the frequency decreases, vice versa.

C31 Feedback gain : 0.00 - 10.0

C31 is feedback gain, that is feedback value = detected value × C31.

C32 P: Proportion gain : 0.00 - 10.0

C32: Proportion gain for P control.

C33 I: Integral time (s) : 00.0 - 100

C33: Integral time for I control

C34 D: Differential time (s) : 0.00 - 10.0

C34: Differential time for D control.

C35 PID offset 000: Positive direction**001: Negative direction****C36 PID offset adjust (%) : 000 ~ 109%**

PID operation result can be adjusted by C36 (C35 effects the polarity of C36).

C37 PID postpone time (s): 00.0 - 02.5

C37: the refresh time of PID output command.

Note: PID function is used in flow control, external fan wind volume control and temperature control. And the control flow is as the following figure:

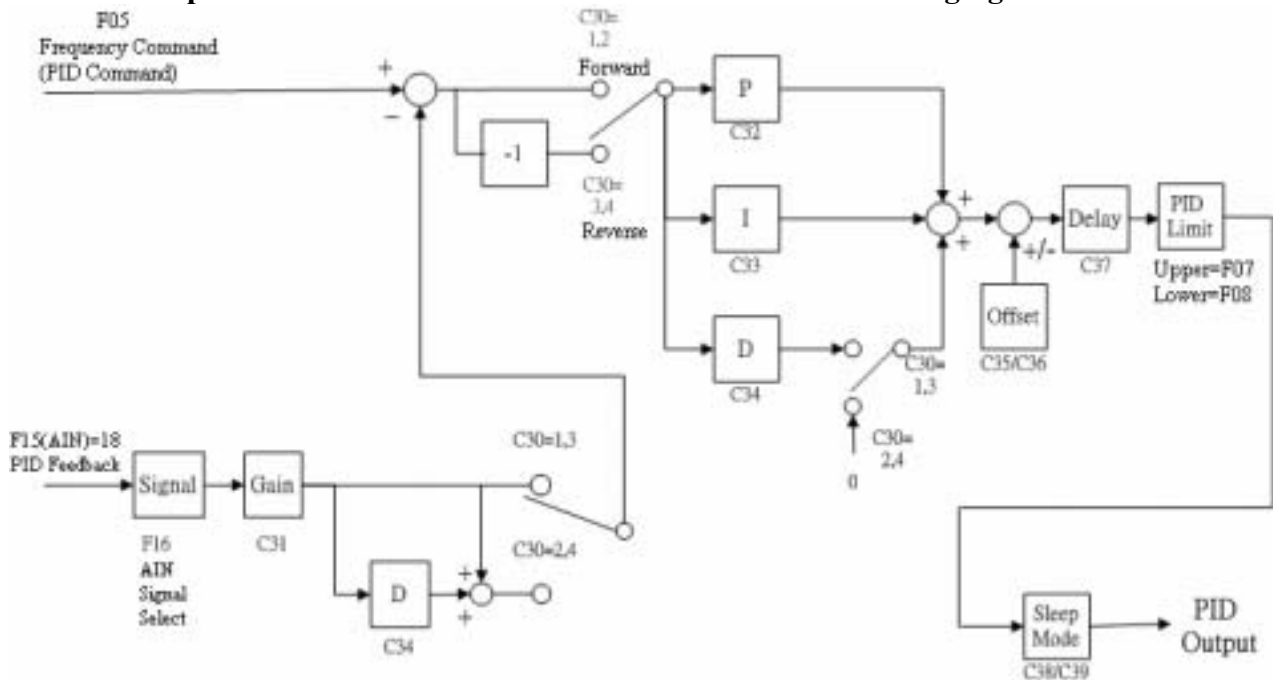

1. In PID mode select, AIN on TM2 as PID feedback signal, Set F15=018.
2. The PID command (Target value) is selected by parameter F05 (selections 000 & 001). This value is stored in F28.

C38 PID Sleep start frequency (Hz) 00.0~200Hz

C39 PID Sleep delay time (sec) 00.0~25.5sec

PID sleep mode must set below function :

- C30=001~004(PID Enable)
- F15=018(AIN is PID feedback signal)
- F28=PID preset frequency
- C38 sleep start frequency, unit: Hz
- C39 PID sleep delay time, unit: Sec

When PID output frequency becomes lower than PID sleep start frequency (C38) for a period of time (C39), then the inverter output will decelerate to zero speed (Sleep mode). When the PID output frequency becomes higher than the sleep start frequency (C38), the inverter output accelerates to PID output frequency (Wake up mode).

Timing diagram is as following:

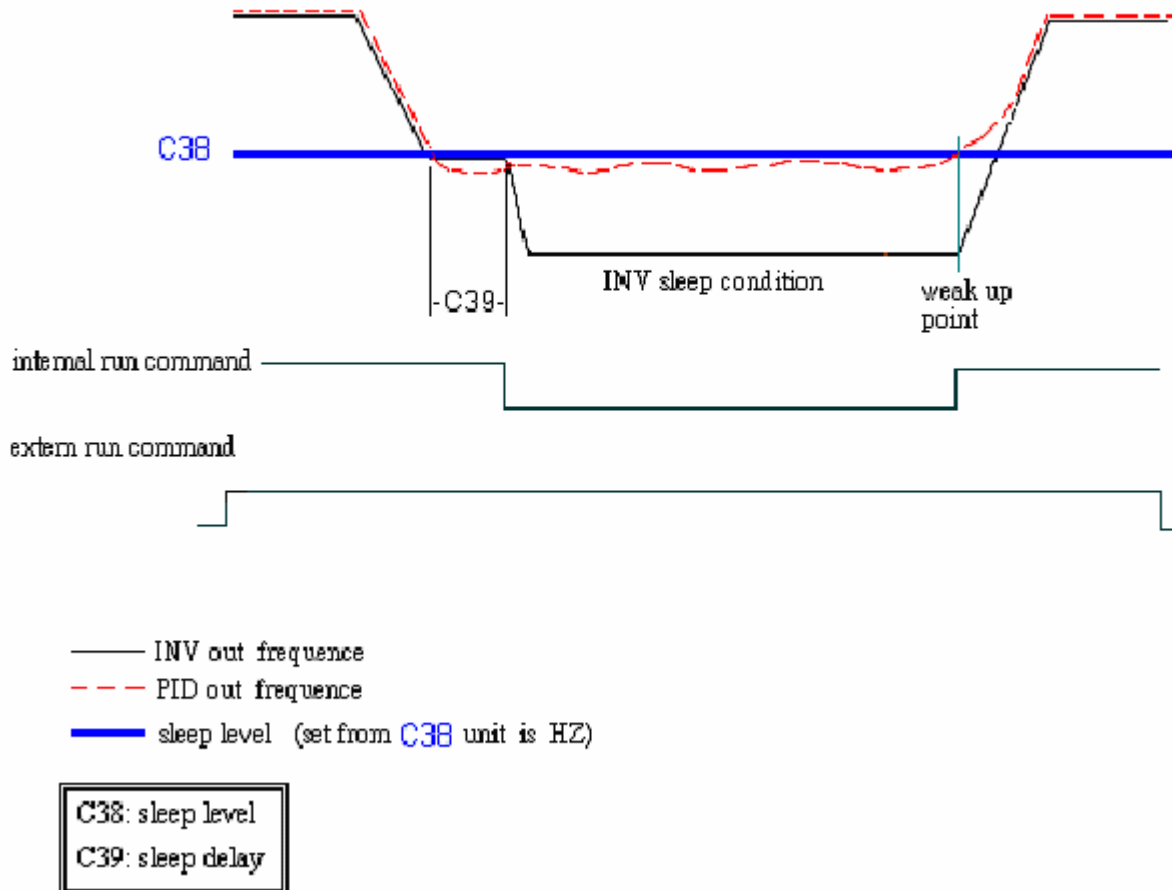

C40 Frequency Up/Down control using MFIT :

000: When using Up/Down command, the set frequency by this function will be stored as the inverter stops.

UP/DOWN function is not available in stop mode.

001: When using Up/Down command, the set frequency will be reset to 0Hz as the inverter stops.

002: When using Up/Down command, the set frequency will be stored as the inverter stops. **UP/DOWN function is available in stop mode.**

- 1) C40=000, when the RUN signal is ON, the inverter will accelerate to F28 then maintain running at the set command speed. When UP/DOWN terminal is activated, the inverter begins to accelerate/decelerate until the signal is released then, it runs at the reached speed.

When the RUN signal is OFF, the inverter decelerates to stop or coasts to stop according to the setting of F09. The frequency, at which the RUN signal is OFF, will be stored in F28.

UP/DOWN Key is unavailable in stop. The stored frequency can not be changed by Up/Down Terminal, but can changing the content of F28 by keypad.

- 2) C40=001, the inverter will run from 0 Hz as run signal is applied.
UP/DOWN operation method is same as C40=000. BUT on next RUN signal is ON, inverter always starts up from 0Hz.

- 3) C40=002. Same as when C40=001 but UP/DOWN is available while in stop mode.

| |
|--|
| C41 Load /Remote control select explain |
|--|

- Locad mode
 - Run command
 - Only Run/Stop pad on the keypad can control and F04 setting have no relationship.
 - Frequency command
 - When C41=000: only UP/DOWN pad on the keypad can control and F05 setting have no relationship.
 - When C41=001: only VR on the keypad can control and F05 setting have no relationship.
- Remote mode
 - Run command from the run parameter (F04) set
 - Frequency command from the frequency parameter (F05) set
- Control select mode pad is V/RESET and DATA/ENT pads push down on the same time can change control mode.(Must be inverter stop state)

| | |
|-----------------------------|--|
| C42/43 (option card) | S5/S6 terminal on MFIT Setting |
| | 000: Forward |
| | 001: Reverse |
| | 002: Preset Speed Command 1 |
| | 003: Preset Speed Command 2 |
| | 004: Preset Speed Command 3 |
| | 005: Jog Frequency Command |
| | 006: Emergency Stop (E.S.) |
| | 007: Base Block (b.b.) |
| | 008: Switching to 2nd acceleration/ deceleration time. |
| | 009: Reset |
| | 010: Up Command |
| | 011: Down Command |
| | 012: Control signal switch |
| | 013: Communication control signal switch |
| | 014: Acceleration/ deceleration disable |
| | 015: Master/ auxiliary speed switch |
| | 016: PID function disable |

Refer to F11~F14

| |
|---|
| C44: Multi-function input terminal S1~S6 signal scan time (N. msec ×8), N = (1~100 times). |
|---|

| |
|---|
| C45: AIN signal scan time (N. msec ×8), N = (1~100 times). |
|---|

- 1.) If the C44 scan time is set to say 80 ms (i.e N=10) then digital input signals on for less than 80 msec will be ignored.
- 2.) If scan the same input signal for N times (scan times), the inverter takes it as normal one. If it is less than N times, it will be taken as noise. One scan time: 8ms.
- 3.) User can set scan interval time according to noise in the operation environment. Extend C44/C45 as noise is serious, however this will reduce the scan response time.

C46 (Option card) Multi-function output T+ , T-

- 000: In running**
- 001: Frequency reached [Preset target frequency \pm F23]**
- 002: Frequency reached [Preset output frequency level (F22) \pm F23]**
- 003: Frequency detection (>F22)**
- 004: Frequency detection (<F22)**
- 005: Fault .**
- 006: Auto-restart**
- 007: Momentary power loss**
- 008: Emergency Stop (E.S.)**
- 009: Base Block (b.b.)**
- 010: Motor overload protection**
- 011: Inverter overload protection**
- 012: retain**
- 013: Power ON**
- 014: Communication error**
- 015: Output current detection**

Refer to F21 description:

C47 Remote keypad control selection

- 000: Disable**
- 001: Enable. Operation according to F09 as wire breaks.**
- 002: Enable. Operation at the last set frequency as wire breaks.**
(Stop mode by Inverter keypad or F04 parameter as appropriate).

When C47=001 , C49~C53 set parameter disable, following parameter will be auto set:

Inverter communication address No 1 Data bytes: 8 bit
 Baud rated (bps): 38400 Parity bytes: no parity
 Stop bytes: 1 bit

- Note:1. Connect remote keypad in stop mode, control priority is with Remote keypad**
2. If the remote keypad is connected in run mode, it will not be effective until the inverter is in stop mode.

C48 Copy module

- 000: Copy module Disabled**
- 001: Copy to module from inverter (Read)**
- 002: Copy to inverter from module (write)**
- 003: Read/ write check (Compare the parameters).**

Note: Module copy function is applicable only to inverters with the same voltage and KW rating.

C49 Inverter communication address: 001~ 254

C49 set communication address, for the specific inverter when multi-inverters are controlled by communication method.

C50 Baud rate (bps)

- 000: 4800**
- 001: 9600**
- 002: 19200**
- 003: 38400**

| | |
|-----------------------|--|
| C51 Stop bit | 000: 1 Stop bit 001: 2 Stop bit |
| C52 Parity bit | 000: No parity 001: Even parity 002: Odd parity |
| C53 Data bits | 000: 8 bits data 001: 7 bits data |

1. RS-485 communication: (requires RS485 port device)

1 to 1 control: PC or PLC or controller controls one inverter (C49 is set to 001~254).

1 to many control: PC or PLC or other controllers control several inverters (as much as 254 inverters with C49 set as 001~254). When the communication address =000, the inverter is controlled by communication regardless of the C49.

2. RS-232communication: (requires RS232 port)

1 to 1 control: PC or PLC or controller controls one inverter (C49 is set to 001~254).

- Note:**
- a. The BAUD RATE(C50) and communication format (C51/C52/C53) of PC (or PLC or other controller) and inverter should be the same.
 - b. The inverter will validate the modified parameters after the parameters modified by PC.
 - c. Communication protocol: refer to 7300EV communication protocol description.
 - d. Parameter C49~C53 can't be change under communication mode.

C54/ C55 Communication error detection time / Communication error operation selection

(1) Time –out detection time: 00.0~25.5sec; setting 00.0 sec: disable time-out function.

Default: 00.0sec

*Cannot be modified during communication.

(2) Time-out operation selection:

000 : Deceleration to stop (F02 : Deceleration time 1).

001 : Free run to stop.

002 : Deceleration to stop(C12 : Deceleration time 2).

003 : Continue operating.

Default=000

*Cannot be modified during communication.

C54/C55 Communication error parameter timing pattern

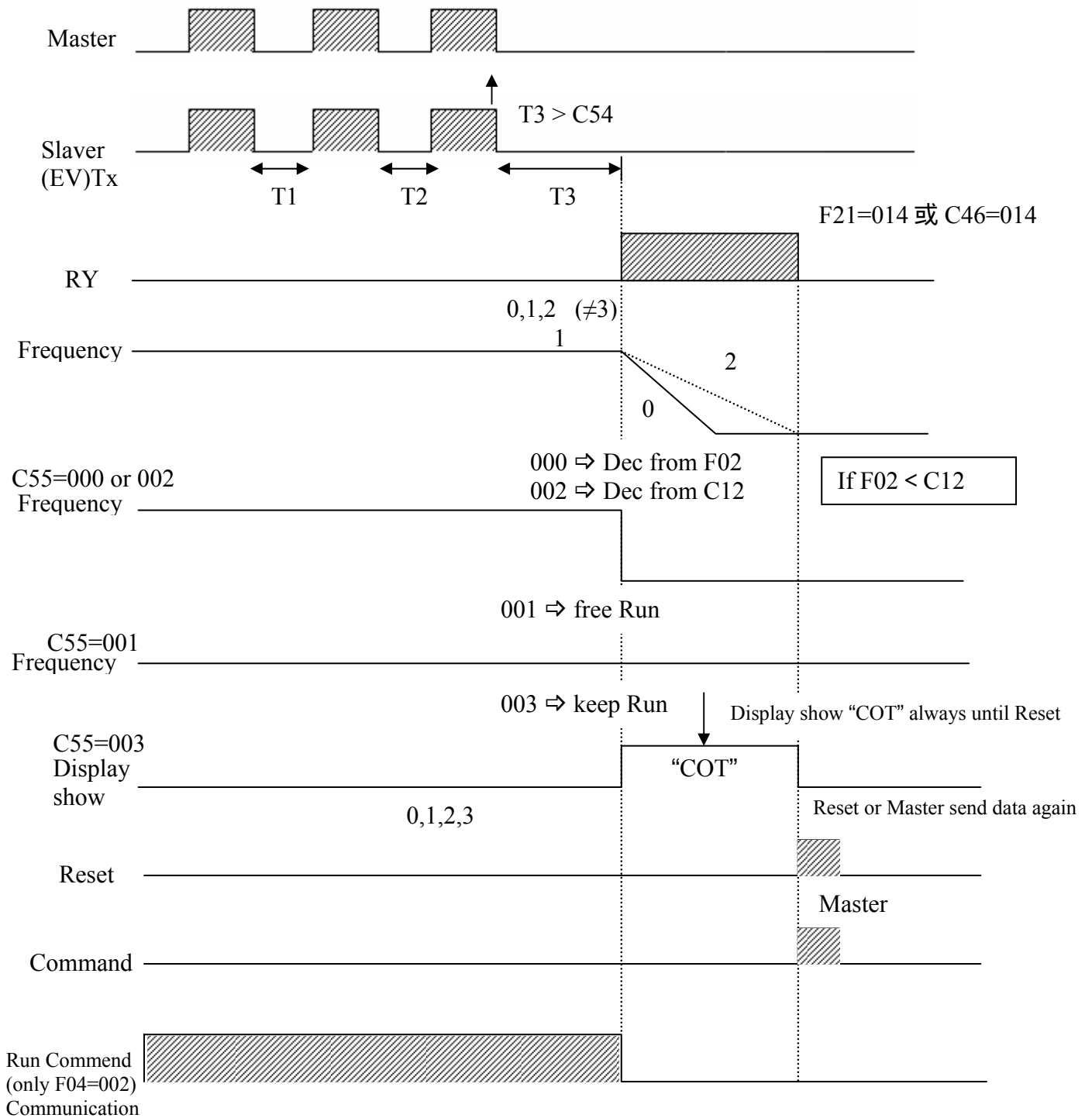

Chapter 5 Troubleshooting and maintenance

5.1 Trouble indication and remedy

5.1.1 Fault/ Error display and Diagnostics

1. Un- resetable / un recoverable Errors

| Display | Error | Cause | Remedy |
|-------------|---|---|--|
| EPR | EEPROM problem | EEPROM problem | Change EEPROM |
| @ OV | Over voltage during stop | Detection circuit malfunction | Send the inverter back for repair |
| @ LV | Under voltage during stop | <ol style="list-style-type: none"> 1. Power voltage too low 2. Restraining resistor or fuse burnt out. 3. Detection circuit malfunctions | <ol style="list-style-type: none"> 1. Check if the power voltage is correct or not 2. Replace the restraining resistor or the fuse 3. Send the inverter back for repair |
| @ OH | The inverter is overheated during stop | <ol style="list-style-type: none"> 1. Detection circuit malfunctions 2. Ambient temperature too high or bad ventilation | <ol style="list-style-type: none"> 1. Send the inverter back for repairing 2. Improve ventilation conditions |
| CTR | Current transducer detection error | Current transducer or circuit error. | Send the inverter back for repair |

Note : "@" the Failure contact does not operate.

2. Errors which can be recovered manually and automatically

| Display | Error | Cause | Remedy |
|----------------|--|---|---|
| OCS | Over current at start | <ol style="list-style-type: none"> 1.The motor winding and frame short circuit 2.Motor and ground short circuit 3.Power module is damaged | <ol style="list-style-type: none"> 1.Check the motor 2.Check the wiring 3.Replace the power module |
| OCD | Over-current at deceleration | The preset deceleration time is too short | Set a longer deceleration time |
| OCA | Over-current at acceleration | <ol style="list-style-type: none"> 1. Acceleration time is too short 2. The capacity of the motor higher than the capacity of the inverter 3.Short circuit between the motor winding and frame. 4.Short circuit between motor wiring and earth 5. IGBT module is damaged | <ol style="list-style-type: none"> 1.Set a longer acceleration time 2.Replace a inverter with the same capacity as that of the motor 3.Check the motor 4.Check the wiring 5. Replace the IGBT module |
| OCC | Over-current during running | <ol style="list-style-type: none"> 1. Transient load change 2. Transient power change | <ol style="list-style-type: none"> 1. Increase inverter capacity |
| OVC | Over voltage during operation/ deceleration | <ol style="list-style-type: none"> 1. Deceleration time setting is too short or large load inertia 2. Power voltage varies widely | <ol style="list-style-type: none"> 1.Set a longer deceleration time 2.Add a brake resistor or brake module 3.Add a reactor at the power input side 4.Increase inverter capacity |
| OHC | High heat sink temperature during operation | <ol style="list-style-type: none"> 1. Heavy load 2. Ambient temperature too high or bad ventilation | <ol style="list-style-type: none"> 1.Check if there are any problems with the load 2.Increase inverter capacity 3.Improve ventilation conditions 4.Inspect the setting value of parameter C13 |

3. Errors which can only be recovered manually but cannot be auto-recovered

| Display | Error | Cause | Remedy |
|------------|---------------------------------------|--|--|
| OC | Over-current during stop | <ol style="list-style-type: none"> 1. Detection circuit malfunctions 2. Bad connection for CT signal cable | Send the inverter back for repair |
| OL1 | Motor overload | <ol style="list-style-type: none"> 1. Heavy load 2. Improper settings of F43 | <ol style="list-style-type: none"> 1. Increase motor capacity 2. Set F43 correctly according to motor nameplate. |
| OL2 | Inverter overload | Heavy load | Increase inverter capacity |
| OCL | Over current limit | <ol style="list-style-type: none"> 1. Heavy Load 2. Continuous over load | <ol style="list-style-type: none"> 1. Increase motor capacity 2. Increase ACC/ DEC time F02~F03 3. set stall prevention function C1~C6 |
| LVC | Under voltage during operation | <ol style="list-style-type: none"> 1. Power voltage too low 2. Power voltage varies widely | <ol style="list-style-type: none"> 1. Improve power quality. 2. Set a longer acceleration time 3. Add a reactor at the power input side 4. Increase inverter capacitor |

Note : "@" means when the inverter broken ,the failure contact does not action.

5.1.2 Set up& Interface Errors.

| Display | Error | Description |
|---------|----------------------------|---|
| SP0 | Zero speed stop | It happens as set frequency <0.1Hz |
| SP1 | Fail to start directly | <ol style="list-style-type: none"> 1. If the inverter is set to external control mode (F04=001), and direct start is disabled (C09=001), the inverter cannot be started and will flash STP1 when Run switch is in ON position when applying power (see descriptions of C09). 2. Direct start is possible when C09=000. |
| SP2 | Keypad emergency stop | <ol style="list-style-type: none"> 1. If the inverter is set as external control mode (F04=001) , the inverter will stop according to the setting of F9 when stop key is pressed. STP2 flashes after stop. Turn the Run switch to OFF and then ON again to restart the inverter. 2. If the inverter is in communication mode and Stop key is enabled, the inverter will stop in the way set by F9 when Stop key is pressed during operation and then flashes STP2. The PC has to send a Stop command then a Run command to the inverter for it to be restarted. |
| E.S. | External emergency stop | The inverter will decelerate to stop and then flashes E.S. when there is an external emergency stop signal via the multi-function input terminals(see descriptions of F11~F14). |
| b.b. | External base block | The inverter stops immediately and then flashes b.b. when external base block is input through the multi-functional input terminal (see descriptions of F11~F14). |
| PID | PID feedback broken | PID feedback signal circuit error detection |
| | REMOTE KEYPAD cable broken | <ol style="list-style-type: none"> 1. REMOTE KEYPAD does not connect with REMOTE KEYPAD, such signal will be displayed. 2. REMOTE KEYPAD connects with main KEYPAD, such signal will be displayed. 3. REMOTE KEYPAD and main KEYPAD both display such signal means communication errors. |

5.1.3 Keypad operation error description

| Display | Error | Cause | Remedy |
|---------|---|--|---|
| Er1 | Key operation error | <ol style="list-style-type: none"> 1. Press ▲ or ▼ keys when F05> 0 or in speed operation. 2. Attempt to modify parameters, which can not be modified during Run (see parameter list). | <ol style="list-style-type: none"> 1. ▲ or ▼ keys can be used to modify frequencies only when F05=0. 2. Modify them after stop. |
| Er2 | Parameter setting error | <ol style="list-style-type: none"> 1. F07 is in ranges of C27±C29 or C28±C29 2. F07 F08 | <ol style="list-style-type: none"> 1. Modify F32~F33 2. 3-00>3-01 |
| Er5 | Modification of parameter is not allowed during communication | <ol style="list-style-type: none"> 1. Issue a control command during communication disabled 2. Modify C49~C53 during communication. | <ol style="list-style-type: none"> 1. Issue the enabling command while communicating. 2. Set up parameters before communicating. |
| Er6 | Communication failure | <ol style="list-style-type: none"> 1. Incorrect cabling. 2. Incorrect settings of communication parameters. 3. Sum-check error. 4. Incorrect communication verification. | <ol style="list-style-type: none"> 1. Check the hardware and wiring. 2. Check C49~C53 |
| Er7 | Incorrect parameter settings | <ol style="list-style-type: none"> 1. Attempt to modify F00 2. Voltage and current detection circuits work abnormally. | Reset inverter. Send for repair |
| EP1 | Parameter set error, Copy Unit failure | <ol style="list-style-type: none"> 1. Set C48=1.2, can not connect with Copy Unit. 2. Copy Unit failure. 3. The voltage and capacity parameter of Copy Unit & the inverter are different. | <ol style="list-style-type: none"> 1. Modify C48 2. Change Copy Unit 3. Copy the same inverter parameter for voltage and capacity, then input. |
| EP2 | Parameters do not match | Copy the parameter to inverter to verify the parameter is not match. | <ol style="list-style-type: none"> 1. Change Copy Unit 2. The voltage and capacity parameter of Copy Unit are different |

5.2 General functional troubleshooting

| Status | Checking point | Remedy |
|--|--|---|
| Motor can not run | Is power applied to L1, L2, and L3(N) terminals (is the charging indicator lit)? | Is the power applied? Turn the power OFF and then ON again. Make sure the power voltage is correct. Make sure screws are secured firmly. |
| | Are there voltage outputs in T1, T2, and T3 terminals? | Turn the power OFF and then ON again. |
| | Is the motor mechanically overloaded? | Reduce the load to let the motor running. |
| | Are there any abnormalities in the inverter? | See error descriptions to check wiring and correct if necessary. |
| | Is forward or reverse running command issued? | |
| | Is there an analog input signal? | Is analog frequency input signal wiring correct? Is voltage of frequency input correct? |
| | Is operation mode setting correct? | Operate operations through the digital panel |
| Motor runs inversely | Are wiring for output terminals T1, T2, and T3 correct? | Wiring must match U, V, and W terminals of the motor. |
| | Are wiring for forward and reverse signals correct? | Check wiring are correct if necessary. |
| Motor runs inversely The motor speed can not vary | Are wiring for output terminals T1, T2, and T3 correct? | Check wiring are correct if necessary. |
| | Is the setting of frequency command source correct? | Check the operation mode setting of the operator. |
| | Is the load too heavy? | Reduce the load. |
| Motor running speed too high or too low | Is the setting of operation mode correct? | Confirm the motor's specifications. |
| | Is the load too heavy? | Confirm the gear ratio. |
| | Are specifications of the motor (poles, voltage...) correct? | Confirm the highest output frequency. |
| Motor speed varies unusually | Is the gear ratio correct? | Reduce the load. |
| | Is the setting of the highest output frequency correct? | Minimize the variation of the load. Increase capacities of the inverter and the motor. |
| | Is the load too heavy? | Add an AC reactor at the power input side if using single-phase power. Check wiring if using three-phase power. |

5.3 Troubleshooting Flowcharts 7300EV Series

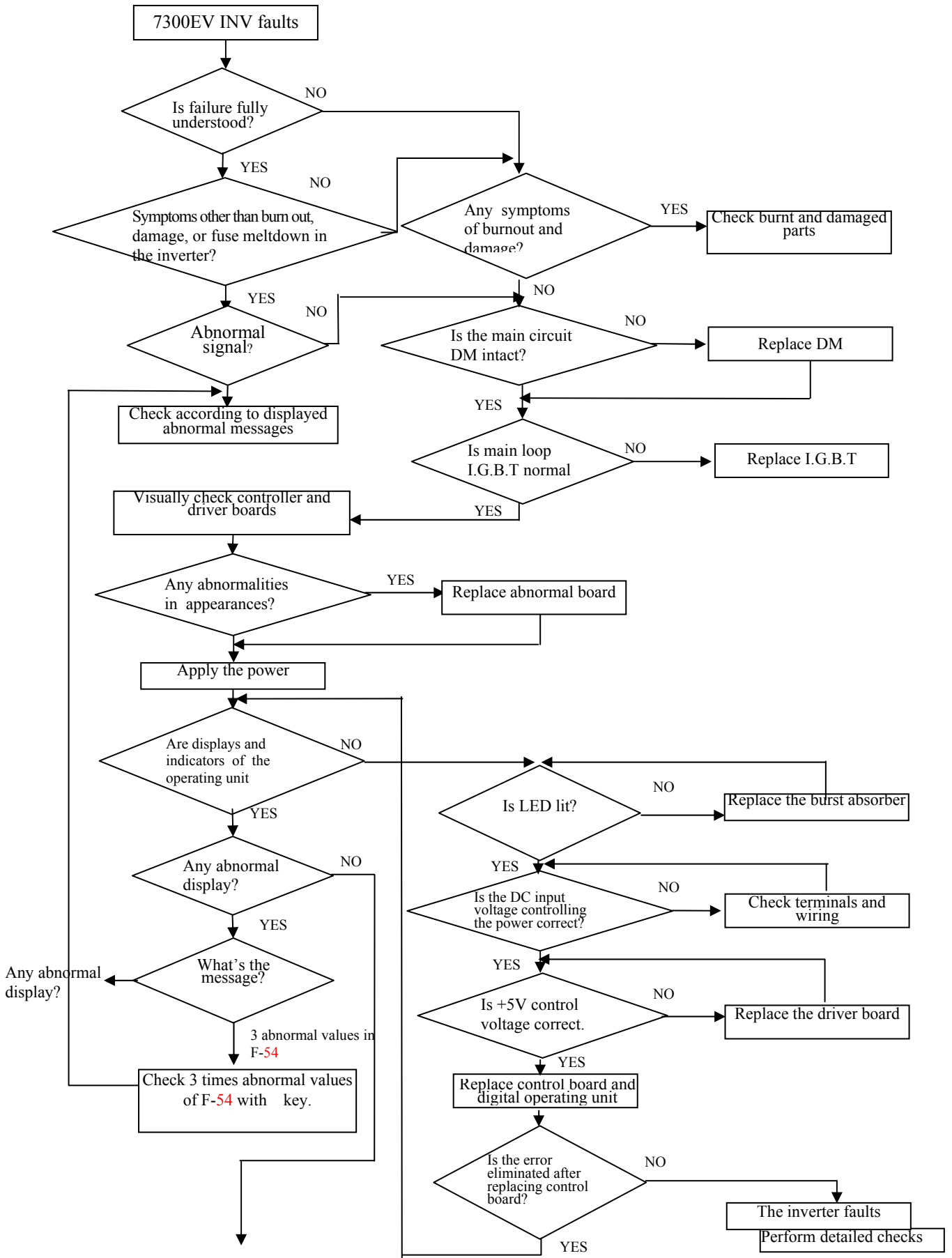

* to next page

* to previous page

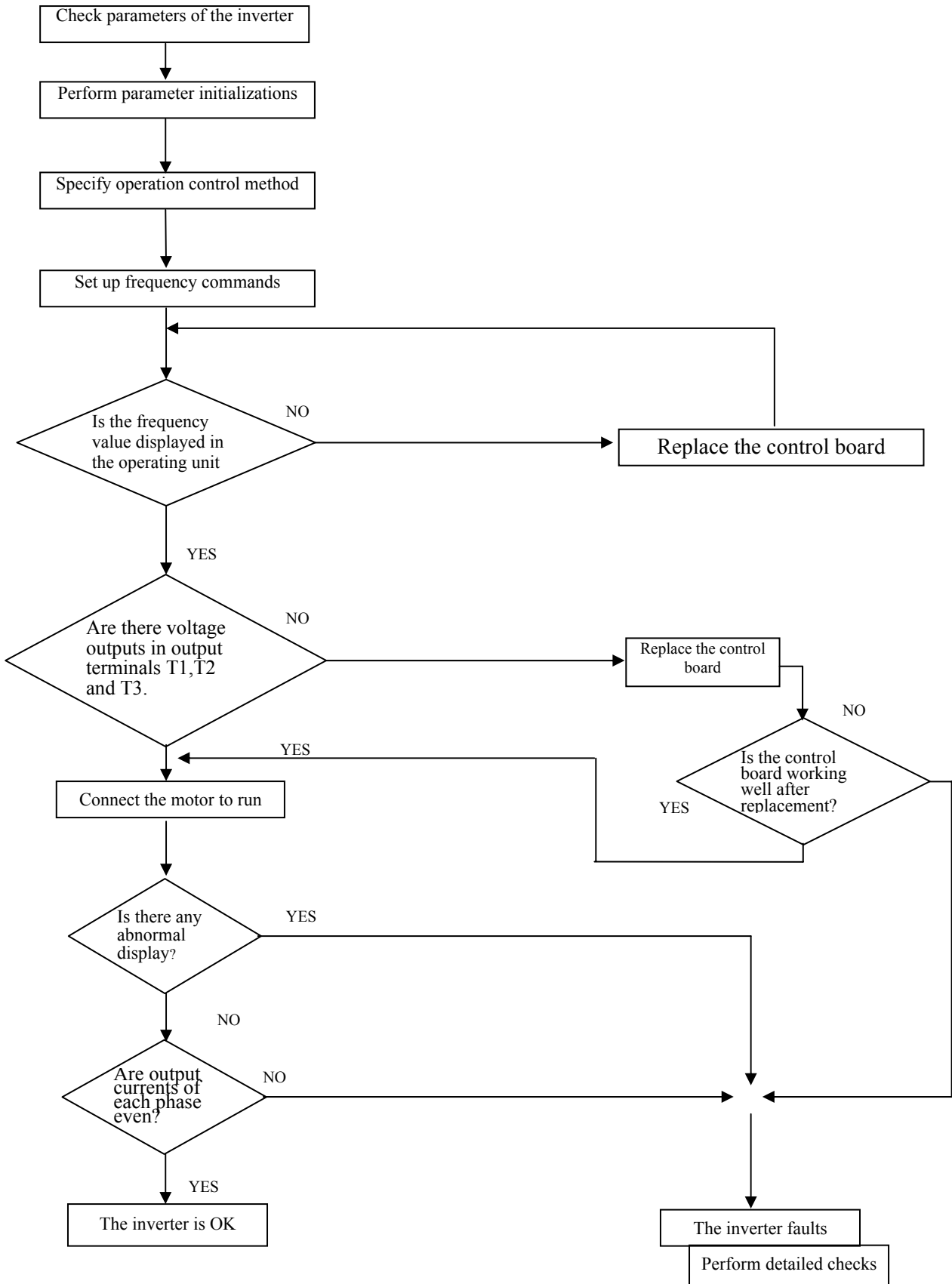

Troubleshooting for OC, OL error displays

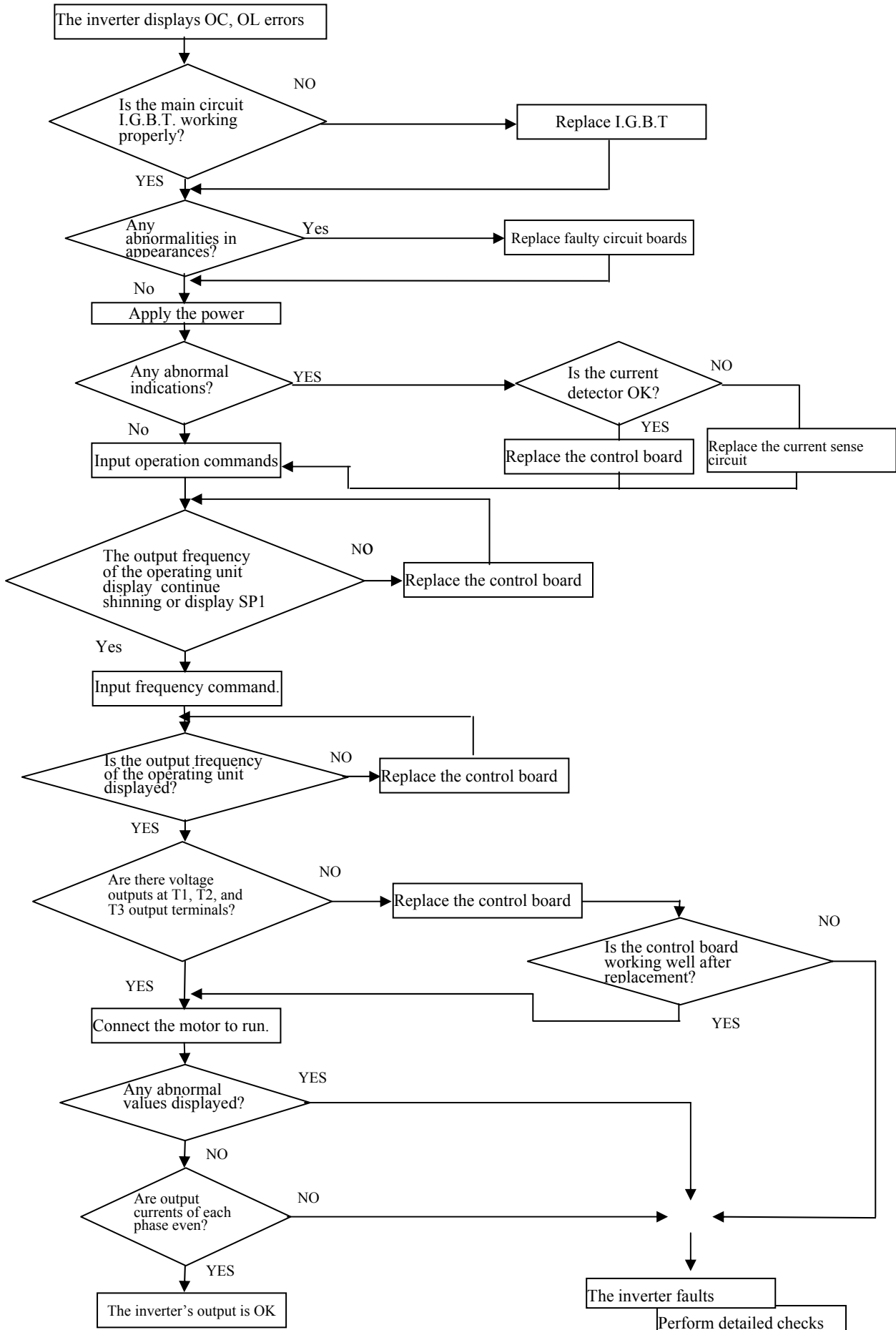

Troubleshooting for OV, LV error display

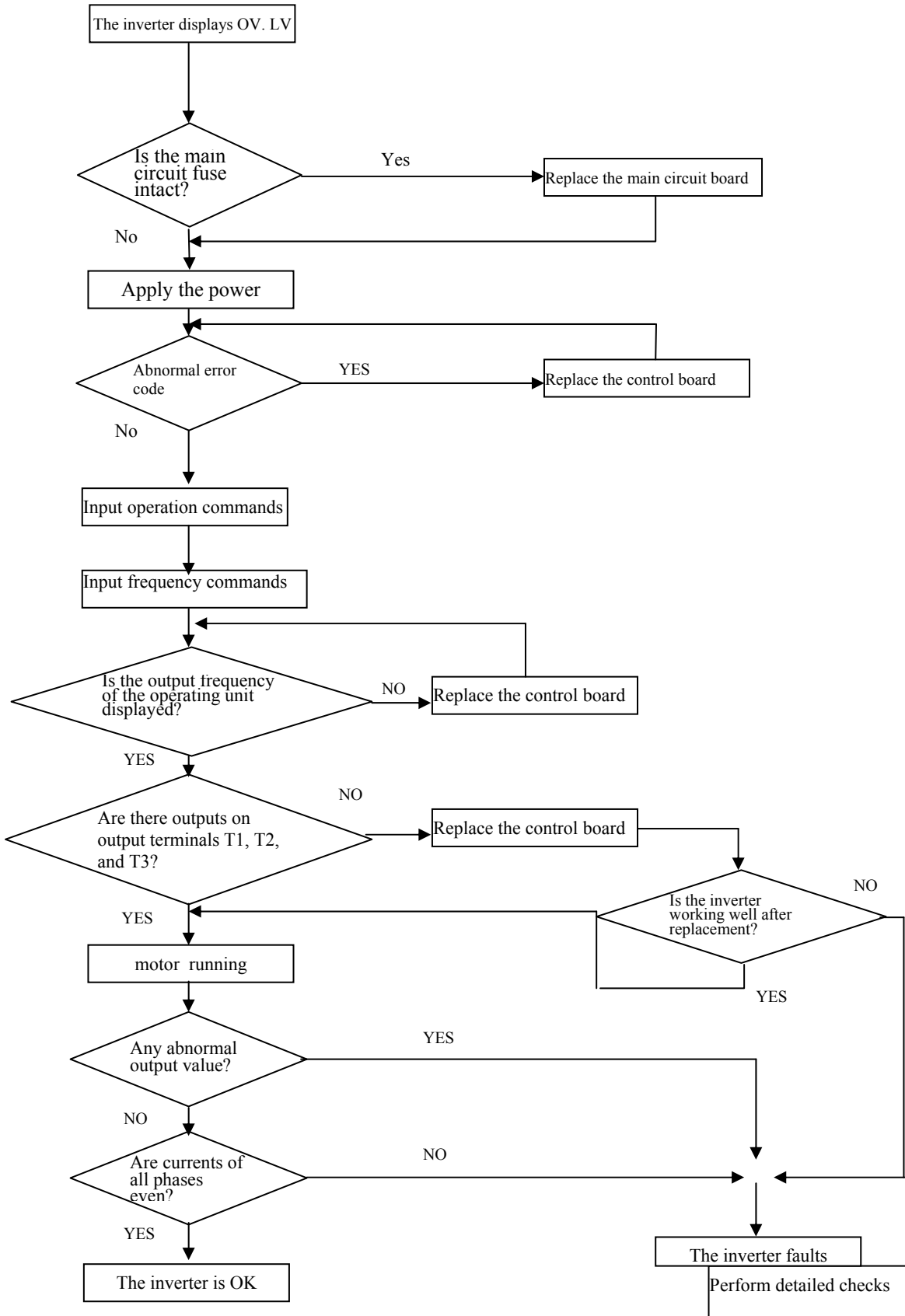

The motor cannot run

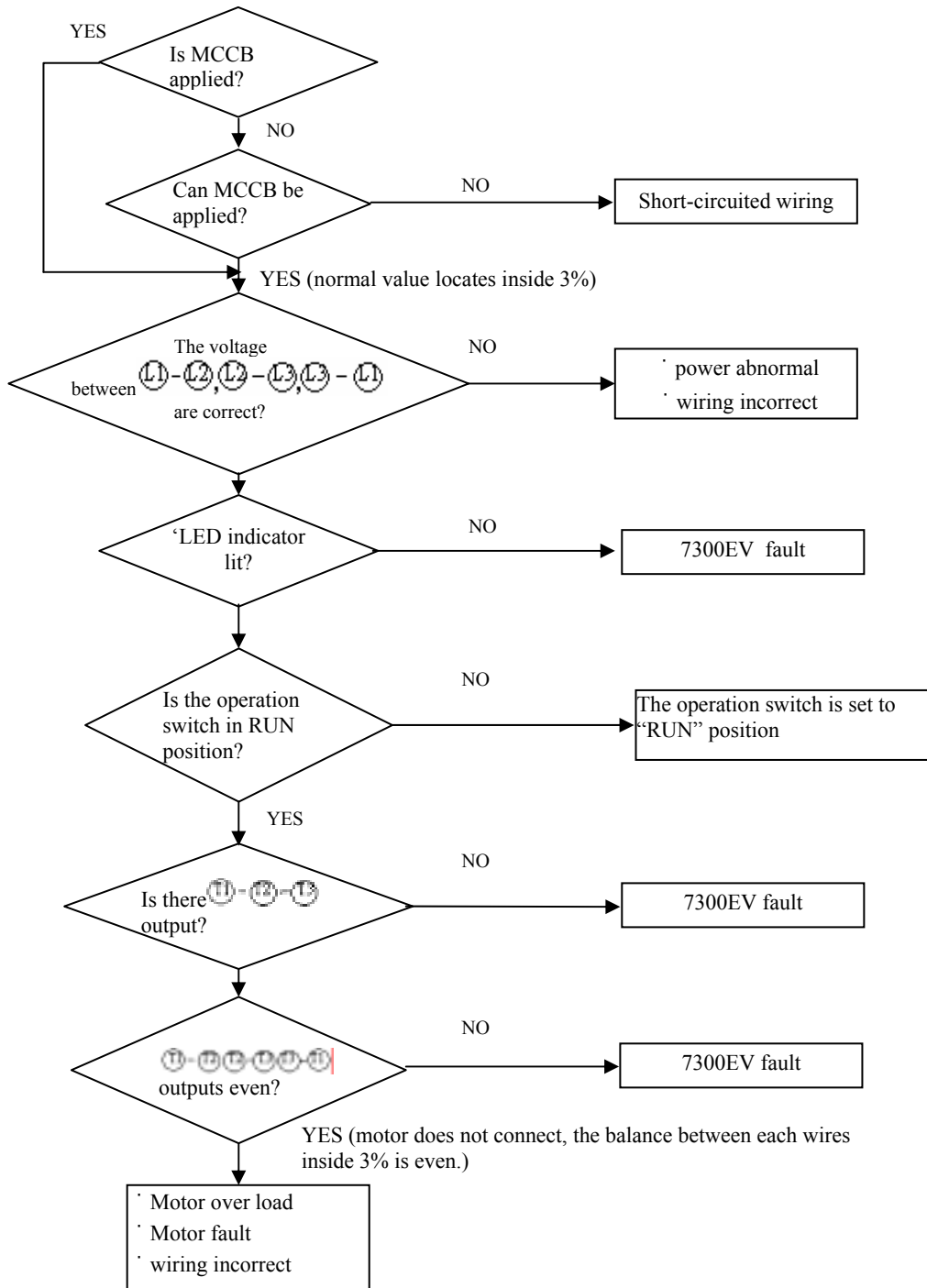

Motor is overheated

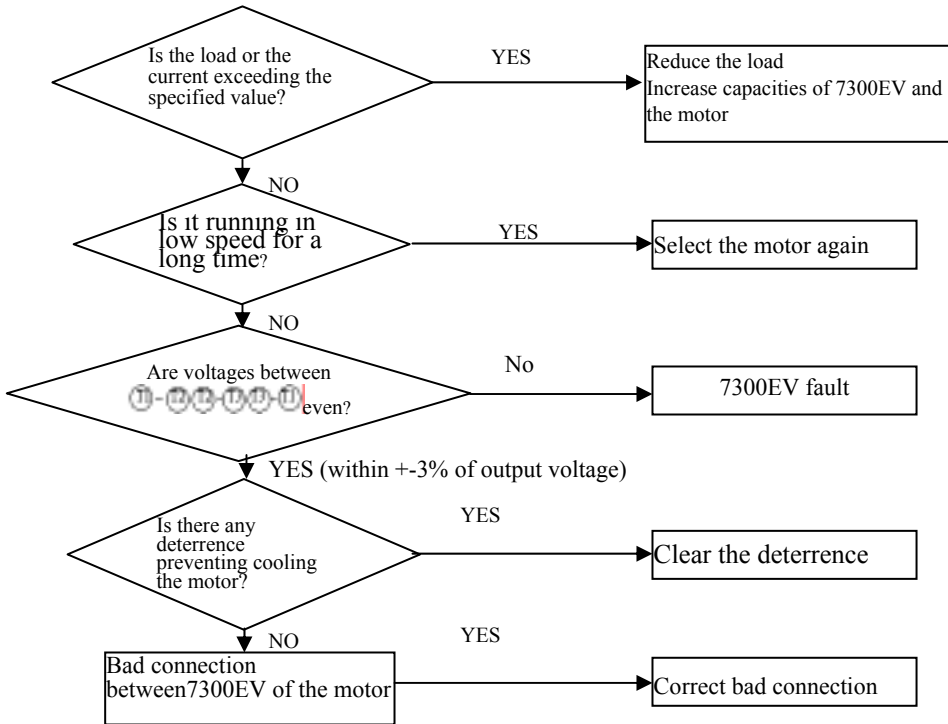

Motor runs unevenly

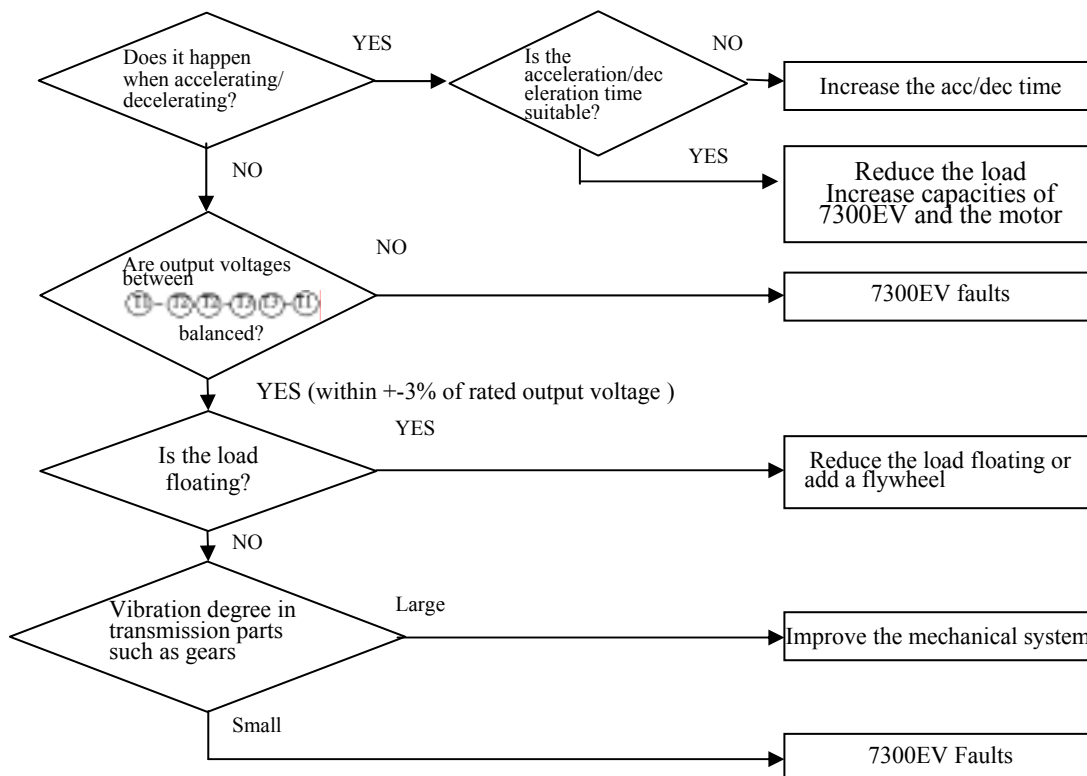

5.4 Routine and periodic checks

To ensure stable and safe operations, check and maintain the inverter regularly and periodically. The table below lists the items to be check to ensure stable and safe operations.

Check these items 5 minutes after the “Charge” indicator goes out to prevent service persons from being hurt by residual electric power.

| Items | Details | Checking period | | Methods | Criteria | Remedies |
|---|---|-----------------|--------|--|--|---------------------------------------|
| | | Daily | 1 year | | | |
| Circumstances around the machine | Confirm the temperature and humidity around the machine | | | Measure with thermometer and hygrometer according to installation notices. | Temperature: -10 – 50°C Humidity: Below 95% RH | Improve the circumstances |
| | Are there inflammables piled up around? | | | Visual check | No foreign matters | |
| Installation and grounding of the inverter | Any unusual vibration from the machine | | | Visual, hearing | No foreign matters | Secure screws |
| | Is the grounding resistance correct? | | | Measure the resistance with the Ground Resistor | 200V series: below 100Ω 400V series: below 10Ω | Improve the grounding |
| Input power voltage | Is the voltage of the main circuit correct? | | | Measure the voltage with a multi-tester | Voltage must conform with the specifications | Improve input voltage |
| External terminals and internal mounting screws of the inverter | Are secure parts loose? | | | Visual check Check with a screwdriver | No abnormalities | Secure or send back for repair |
| | Is the terminal base damaged? | | | | | |
| | Obvious rust stains | | | | | |
| Internal wiring of the inverter | Deformed or crooked | | | Visual check | No abnormalities | Replace or send back for repair |
| | Any damage of the wrapping of the conducting wire | | | | | |
| Heat sink | Heap of dust or mingled trifles | | | Visual check | No abnormalities | Clean up heaped dust |
| Printed circuit board | Heap of conductive metal or oil sludge | | | Visual check | No abnormalities | Clean up or replace the circuit board |
| | Discolored, overheated, or burned parts | | | | | |
| Cooling fan | Unusual vibration and noise | | | Visual or hearing check | No abnormalities | Replace the cooling fan |
| | Heap of dust or mingled trifles | | | Visual check | | Clean up |
| Power component | Heap of dust or mingled trifles | | | Visual check | No abnormalities | Clean up |
| | Check resistance between each terminals | | | Measure with a multi-tester | No short circuit or broken circuit in three-phase output | Replace power component or inverter |
| Capacitor | Any unusual odor or leakage | | | Visual check | No abnormalities | Replace capacitor or inverter |
| | Any inflation or protrusion | | | | | |

5.5 Maintenance and inspection

Inverter doesn't need daily inspection and maintenance.

To ensure long-term reliability, follow the instructions below to perform regular inspection. Turn the power off and wait for the keypad LED display to go out before inspection to avoid potential shock hazard possibly caused by charges resides in high-capacity capacitors.

- (1) Clean up the accumulation of muck inside the inverter.
- (2) Check if there are any loose terminal screws and securing screws. Tighten all loose screws.
- (3) Insulation tests
 - (a) Disconnect all leads connecting 7300EV with external circuit when performing insulation tests against external circuit.
 - (b) Internal insulation test should be performed against the main circuit of the 7300EV inverter only. Use a high resistance DC 500V meter with insulating resistance higher than $5M\Omega$.

Caution! Do not perform this test against the control circuit.

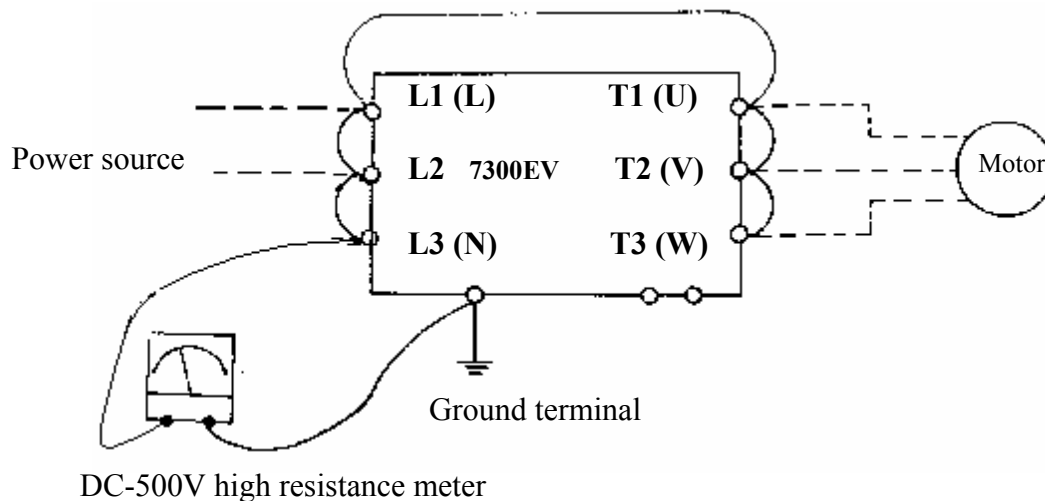

Chapter 6 Peripherals Components

6.1 Input side AC reactor

| Model | | input side AC inductance | |
|------------------|------------------|--------------------------|-----------------|
| | | Current (A) | inductance (mH) |
| JNEV-XXX- HXX | 2P2/2P5-H1(F)/H3 | 5.0 | 2.1 |
| | 201-H1(F)/H3 | 5.0 | 2.1 |
| | 202-H1(F)/H3 | 19.0 | 1.1 |
| | 203-H1(F)/H3 | 25.0 | 0.71 |
| | | | |
| | 401- H3(F) | 2.5 | 8.4 |
| | 402- H3(F) | 5.0 | 4.2 |
| | 403- H3(F) | 7.5 | 3.6 |
| | | | |

6.2 EMC filter

The inverter adopts rapid switching components to improve the efficiency of the motor and to reduce the motor noise. Using the EMC Filter allows the EMI (Electromagnetic Interference)and RFI(Radio Frequency interference)to be controlled within certain range.

EMC standard

The inverter with filter can comply with EMC standard 89/336/EEC on electro-magnetic interruption and radio interruption. The inverters with filter have passed following test and comply with the specified standard.

EMI radio standard and EMS immunity standard:

EN 61800-3 1996/A11: 2000 : First Environment Unrestricted Distribution.

EN 61800-3 1996/A11: 2000 : First Environment Restricted Distribution.

Filter selection:

| Inverter model | | Rated (INPUT) | Build in Filter model (First Environment Unrestricted Distribution./ Restricted Distribution.) | Option Filter model (First Environment Unrestricted Distribution./ Restricted Distribution.) |
|-----------------|---------|--------------------|---|---|
| JNEVXXX -HXX | 1P2-H1 | 1 ϕ 85 ~132V | | JNFS21017-20.8-07 (Restricted Distribution.) |
| | 1P5-H1 | 1 ϕ 85 ~132V | | JNFS21017-20.8-07 (Restricted Distribution.) |
| | 101-H1 | 1 ϕ 85 ~132V | | JNFS21017-20.8-07 (Restricted Distribution.) |
| | 2P2-H1 | 1 ϕ 170 ~264V | | JNFS21017-20.8-07 (Restricted Distribution.) |
| | 2P5-H1 | 1 ϕ 170 ~264V | | JNFS21017-20.8-07 (Restricted Distribution.) |
| | 201-H1 | 1 ϕ 170~264V | | JNFS21017-20.8-07 (Restricted Distribution.) |
| | 2P2-H1F | 1 ϕ 170~264V | Built in (Unrestricted Distribution.) | |
| | 2P5-H1F | 1 ϕ 170 ~264V | Built in (Unrestricted Distribution.) | |
| | 201-H1F | 1 ϕ 170 ~264V | Built in (Unrestricted Distribution.) | |
| | 2P2-H3 | 3 ϕ 170 ~264V | | JNFS21019-8.9-07 (Restricted Distribution.) |
| | 2P5-H3 | 3 ϕ 170 ~264V | | JNFS21019-8.9-07 (Restricted Distribution.) |
| | 201-H3 | 3 ϕ 170 ~264V | | JNFS21019-8.9-07 (Restricted Distribution.) |
| | 202-H1 | 1 ϕ 170 ~264V | | JNFS21015-22-07 (Unrestricted Distribution.) |
| | 203-H1 | 1 ϕ 170 ~264V | | JNFS21015-22-07 (Unrestricted Distribution.) |
| | 202-H1F | 1 ϕ 170 ~264V | Built in (Unrestricted Distribution.) | |
| | 203-H1F | 1 ϕ 170 ~264V | Built in (Unrestricted Distribution.) | |
| | 202-H3 | 3 ϕ 170 ~264V | | JNFS21016-15-07 (Unrestricted Distribution.) |
| | 203-H3 | 3 ϕ 170 ~264V | | JNFS21016-15-07 (Unrestricted Distribution.) |
| | 401-H3 | 3 ϕ 323~528 V | | JNFS20858-7-07 (Restricted Distribution.) |
| | 402-H3 | 3 ϕ 323~528 V | | JNFS20858-7-07 (Restricted Distribution.) |
| | 403-H3 | 3 ϕ 323~528 V | | JNFS20858-7-07 (Restricted Distribution.) |
| | 401-H3F | 3 ϕ 323~528 V | Built in (Restricted Distribution.) | |
| | 402-H3F | 3 ϕ 323~528 V | Built in (Restricted Distribution.) | |
| | 403-H3F | 3 ϕ 323~528 V | Built in (Restricted Distribution.) | |

7300EV EXTERNAL FILTER SIZE

- **JNFS21017-20.8-07 FOR EV-1P2~201-H1**

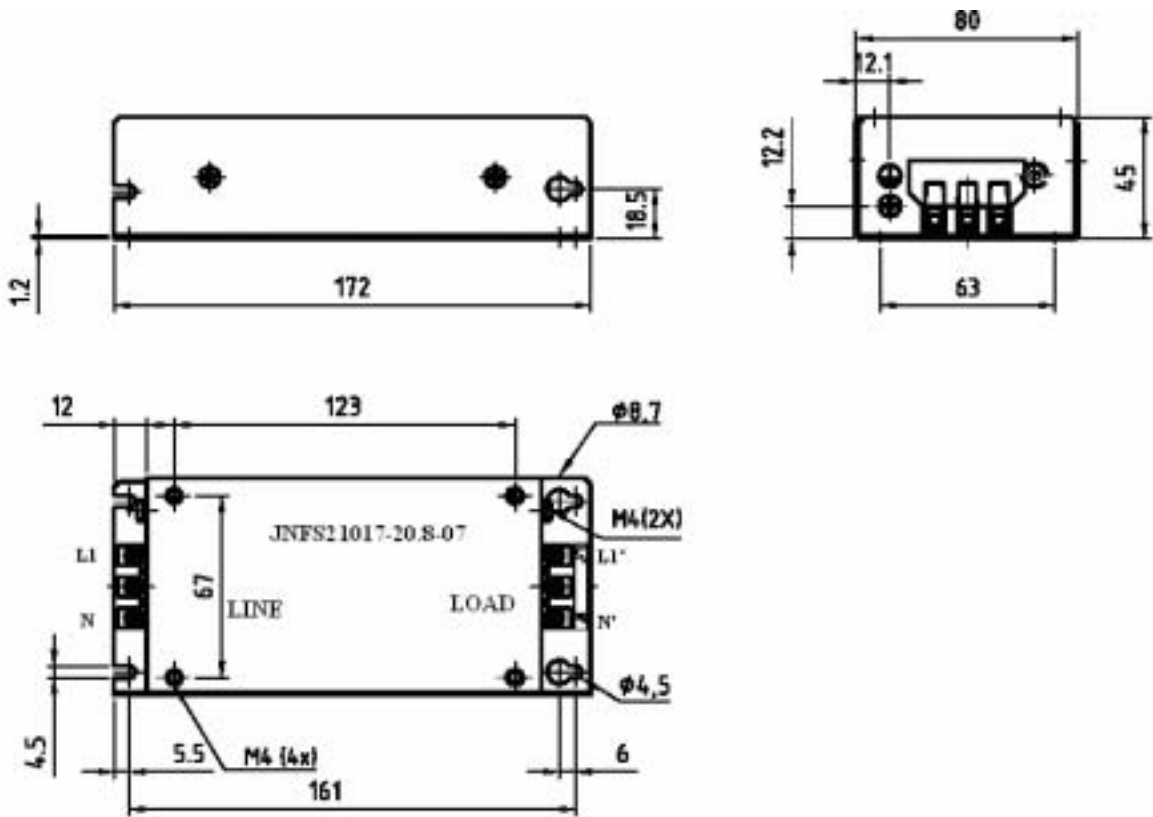

- **JNFS21019-8.9-07 FOR EV-2P2~201-H3**

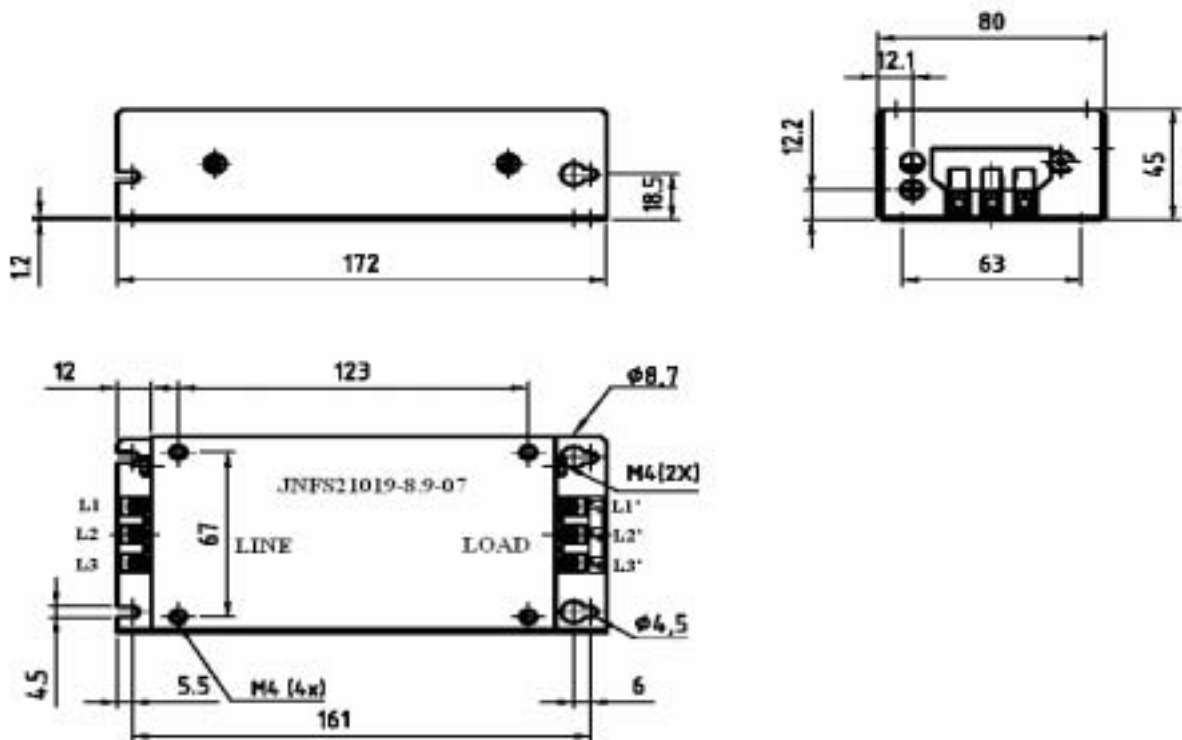

- JNFS21015-22-07 FOR EV-202~203-H1

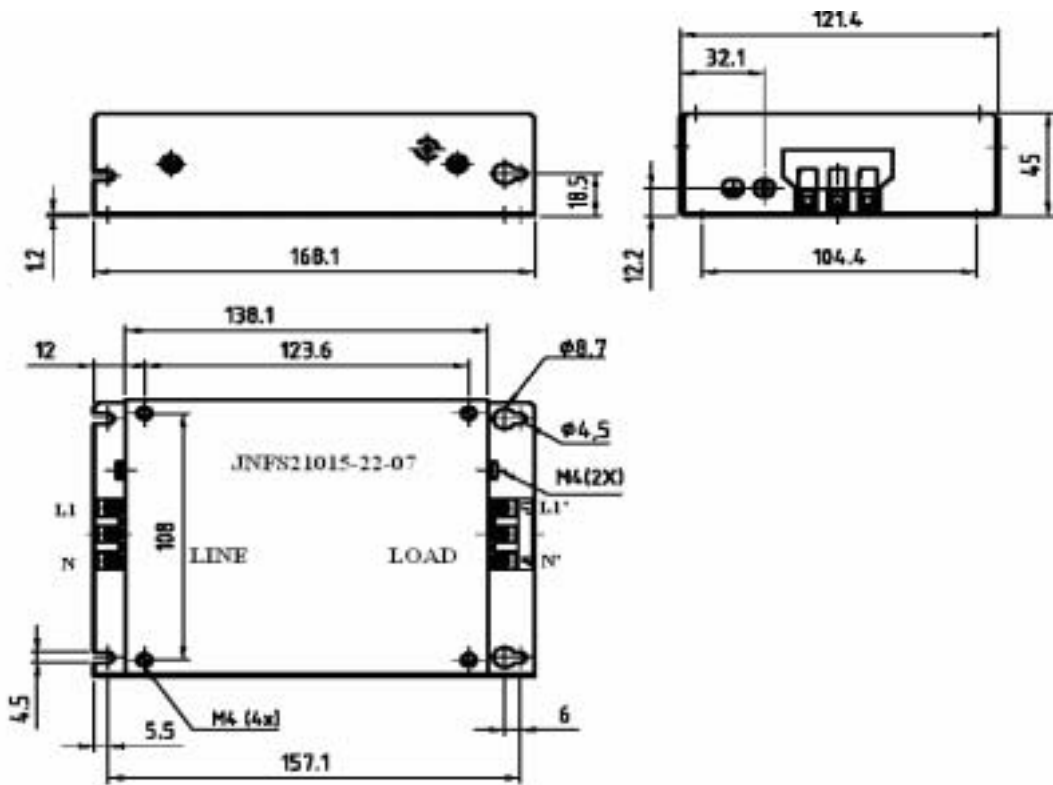

- JNFS21016-15-07 FOR EV-202~203-H3

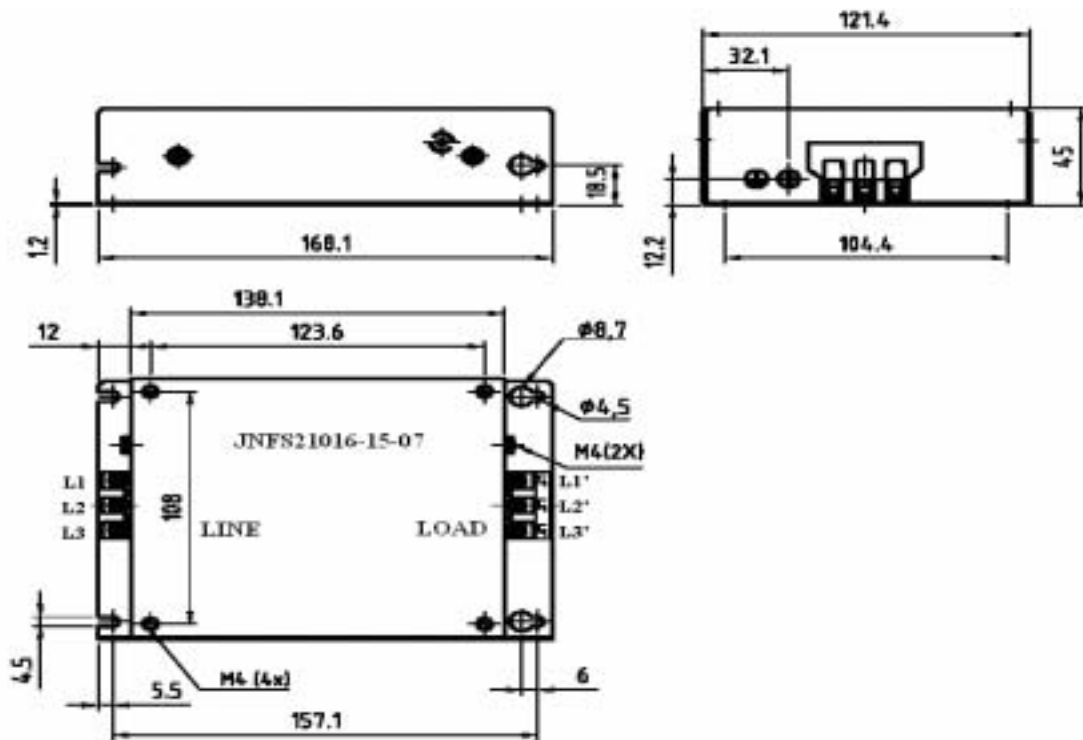

6.3 Option card

6.3.1 RS-485 option card (Model: JNSIF-485)

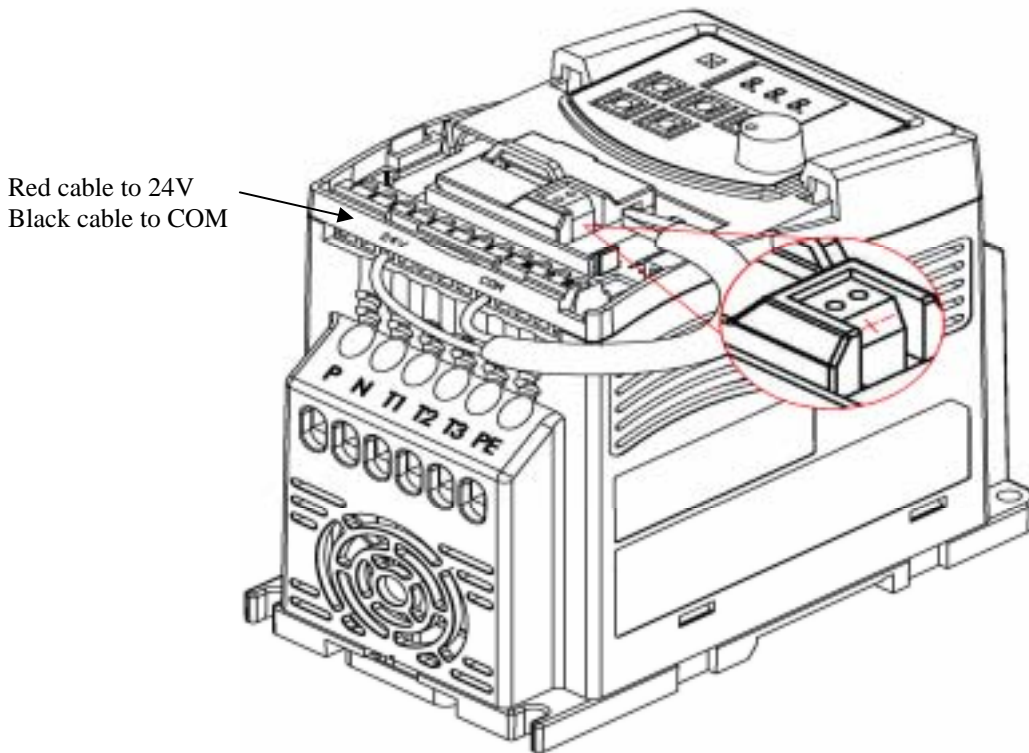

JNSIF-485 wiring diagram:

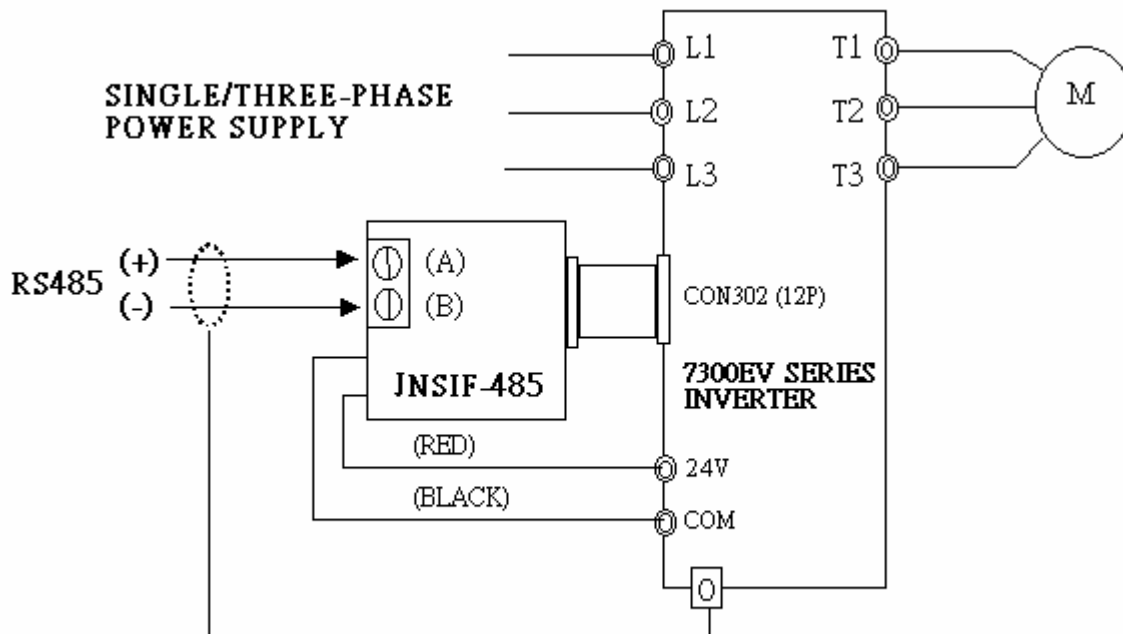

Note :

In order to avoid external static electricity interfere with option card function, please cover the up cover to the main unit as all option card served.

Please use isolated RS232 / RS485 converter connecting with PC and adaptor card to avoid damaging configuration.

6.3.2 RS-232 option card (model: JNSIF-232)

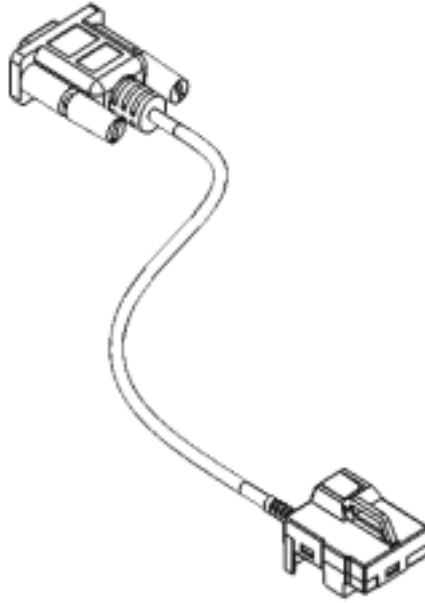

JNSIF-232 wiring diagram

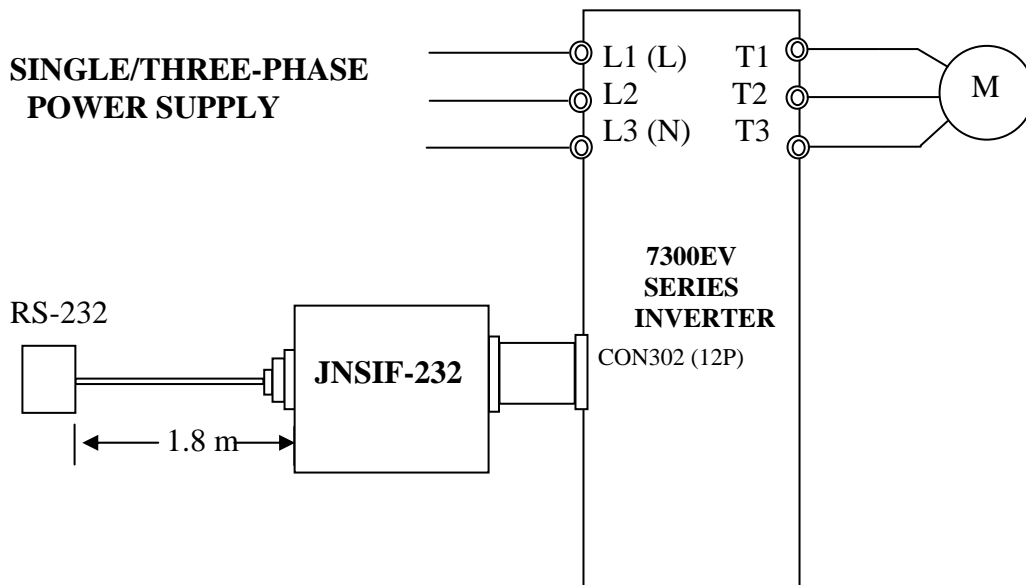

6.3.3 program copy option card (Copy Unit) (model: JNSIF-MP)

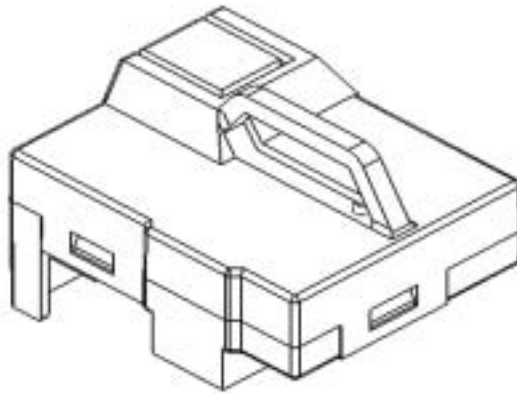

JNSIF-MP Wiring diagram

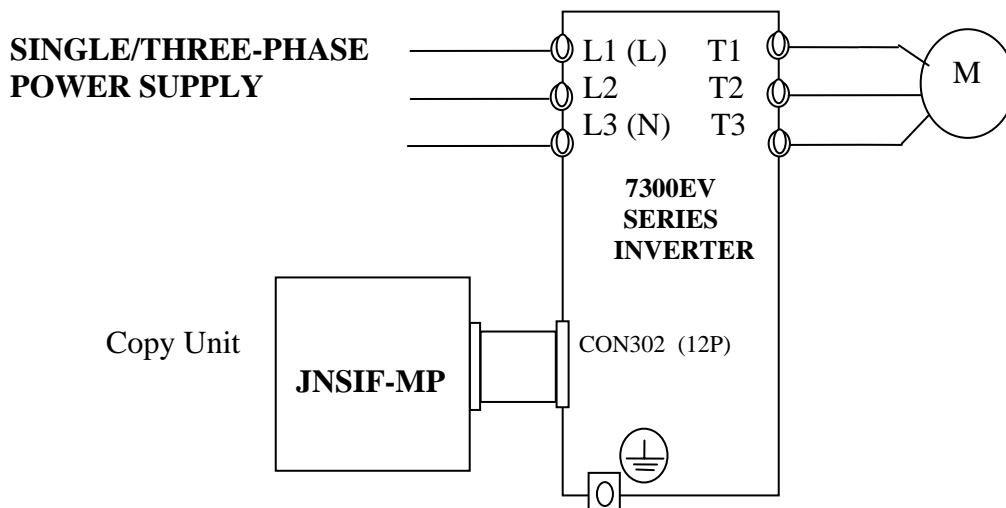

6.3.4 Remote keypad (Remote keypad)(Model: JNSDOP-LED-2M)

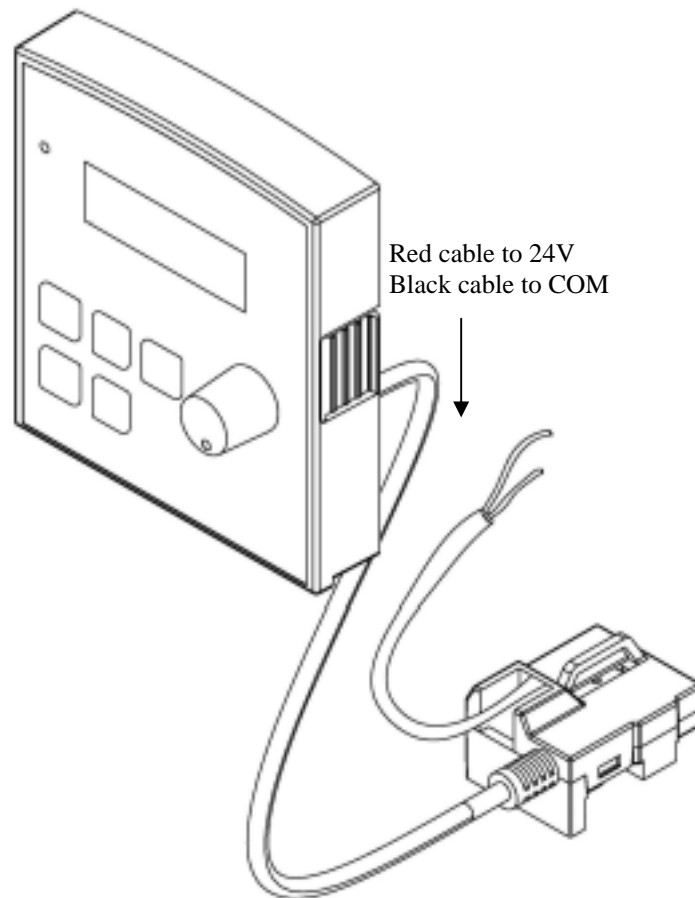

JNSDOP-LED-2M wiring diagram

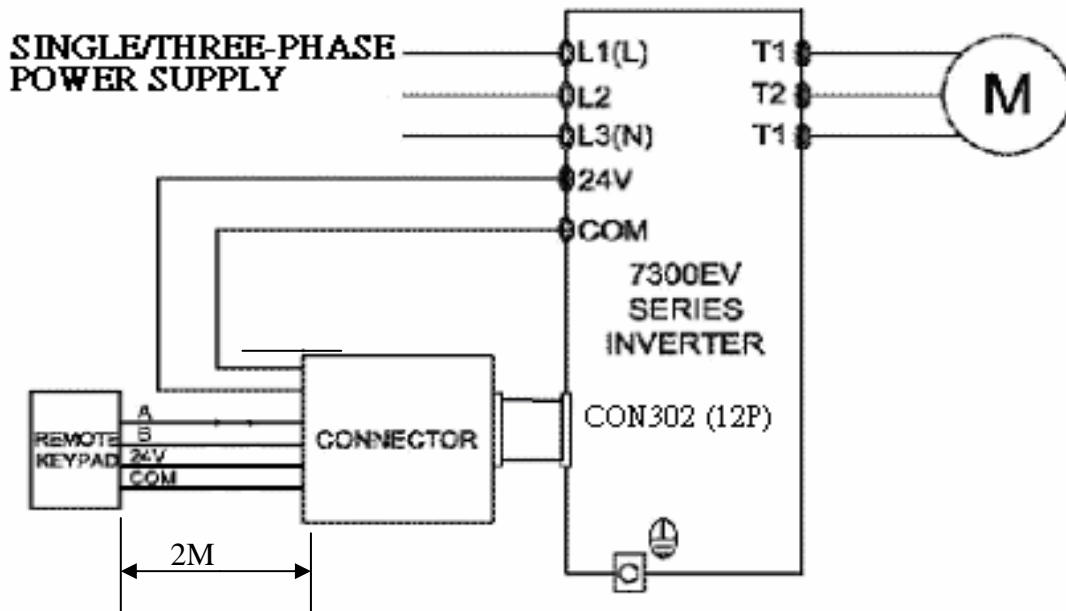

When the inverter is power on or off can set up or remove the remote keypad, but must connect TM2 24V DC power will normal use.

6.3.5 2 In/1 Out card(model: JNSIF-IO)

Red cable to 24V
Black cable to COM

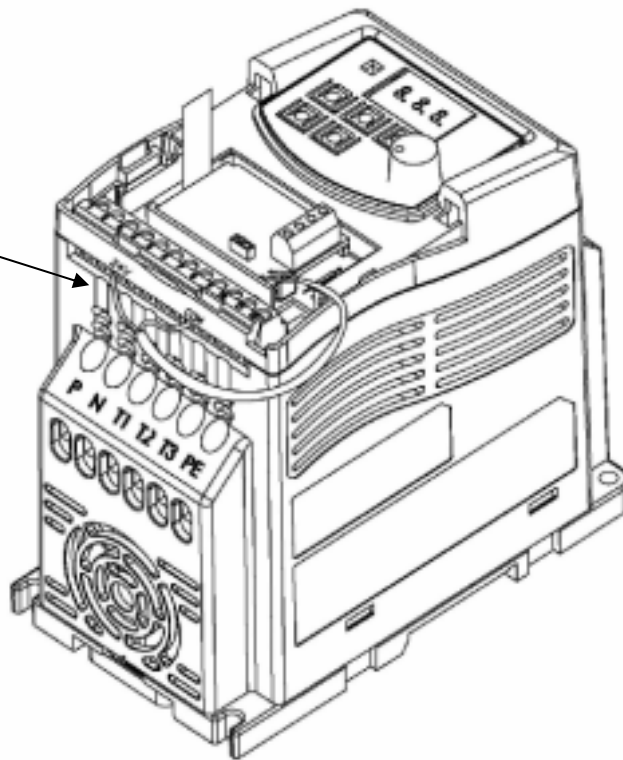

JNSIF-IO wiring diagram

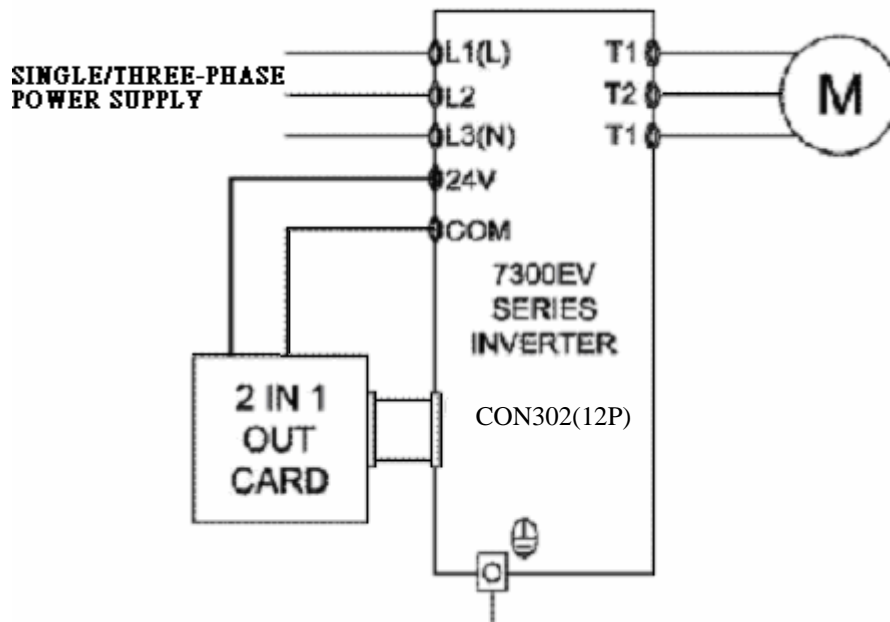

Appendix 7300E Inverter parameter setting list

| Customer Name | | Model of the inverter: | | | |
|---------------------|---------|------------------------------|---------|----------------|---------|
| Location of use: | | Customer's telephone number: | | | |
| Customer's address: | | | | | |
| Parameter code | Setting | Parameter code | Setting | Parameter code | Setting |
| F00 | | F38 | | C22 | |
| F01 | | F39 | | C23 | |
| F02 | | F40 | | C24 | |
| F03 | | F41 | | C25 | |
| F04 | | F42 | | C26 | |
| F05 | | F43 | | C27 | |
| F06 | | F44 | | C28 | |
| F07 | | F45 | | C29 | |
| F08 | | F46 | | C30 | |
| F09 | | F47 | | C31 | |
| F10 | | F48 | | C32 | |
| F11 | | F49 | | C33 | |
| F12 | | F50 | | C34 | |
| F13 | | F51 | | C35 | |
| F14 | | F52 | | C36 | |
| F15 | | F53 | | C37 | |
| F16 | | F54 | | C38 | |
| F17 | | C01 | | C39 | |
| F18 | | C02 | | C40 | |
| F19 | | C03 | | C41 | |
| F20 | | C04 | | C42 | |
| F21 | | C05 | | C43 | |
| F22 | | C06 | | C44 | |
| F23 | | C07 | | C45 | |
| F24 | | C08 | | C46 | |
| F25 | | C09 | | C47 | |
| F26 | | C10 | | C48 | |
| F27 | | C11 | | C49 | |
| F28 | | C12 | | C50 | |
| F29 | | C13 | | C51 | |
| F30 | | C14 | | C52 | |
| F31 | | C15 | | C53 | |
| F32 | | C16 | | C54 | |
| F33 | | C17 | | C55 | |
| F34 | | C18 | | | |
| F35 | | C19 | | | |
| F36 | | C20 | | | |
| F37 | | C21 | | | |