

Solution Drive

Active



BONFIGLIOLI

Active 401/201

Inverter



Bonfiglioli Active frequency inverters are powerful and innovative units specifically designed to control electric motors in sophisticated automation systems.

Bonfiglioli Active range includes both single and three phase units for mains voltages of 230 V or 400 V, ranging from 0.55 kW to 132 kW.

Power ratings within Active range have been chosen to ensure a perfect match with Bonfiglioli motor ratings. The use of Active drives together with Bonfiglioli electric motors exploits at best technical synergy between these two product series.

Hardware flexibility is a fundamental feature of the Active series, and is achieved by means of a generous selection of expansion and communication modules that can be used to "configure" inverters to suit specific application requirements.

Active 401/201 is a "System Drive". Thanks to integrated PLC functions and wide connectivity with mostly used bus systems, Active 401/201 integrates seamlessly with a vast range of automation solutions.

Other main features of Active series:

- extremely compact dimensions
- accurate motor control and silent running, thanks to an 8 kHz switching frequency without derating
- easy mounting and connections, with a large number of panel mounting kits and easy disconnectable plug-in terminals
- exceptional software configurability through a streamlined, intuitive user interface
- versatile control, with very few configuration parameters needed to drive synchronous and asynchronous, feedback and sensorless, braked and brakeless motors
- choice of motor control technologies, including robust scalar control, vectorial sensorless control and accurate field-oriented feedback control: Active frequency converters provide an adequate level of accuracy and dynamics to satisfy the needs of a wide range of applications
- speed and position synchronisation in "multi-drive" automation systems
- extensive choice of accessories, all guaranteed and tested with Active drives, including mains side inductors, EMC filters and braking resistors

Active frequency inverters provide the perfect control solution for any application, from the simplest machine automation systems to the most complex control architectures granting perfectly repeatable high-tech results.

The range of BONFIGLIOLI frequency inverters

ACTIVE series

0,55 ... 132 kW



VCB series

37 ... 800 kW



SYNPLUS series

0,37 ... 11 kW



SYNTHESIS series

0,2 ... 2,2 kW



LMD series

0,37 ... 3,0 kW



Designation

ACT201-13 F A MPSV EMSYS CMCAN KP500

USER INTERFACE

KP500 = programming control unit
KP232 = RS232 serial interface

COMMUNICATION MODULES

CM-CAN = CANopen communication module
CM-PDP = Profibus DP communication module
CM-232 = RS232 serial communication module
CM-485 = RS485 serial communication module

EXPANSION MODULES

EM-SYS = SYSTEMBUS expansion module
EM-IO-xy = I/O expansion modules
EM-ENC-xy = ENCODER expansion modules
EM-RES-xy = RESOLVER expansion modules

INSTALLATION COMPONENTS

MPSV = thru-type mechanical installation kit without fan
MDIN = DIN rail mechanical installation kit
MNVIB = antivibration mechanical installation kit

CONSTRUCTION STYLE

A = style with standard cooling
C = style with cold-plate cooling

EMI FILTER

F = internal filter
- = no internal filter

SIZE

Size 1 ACT201-05 = 0,55 kW
ACT201-07 = 0,75 kW
ACT201-09 = 1,1 kW
Size 2 ACT201-11 = 1,5 kW
ACT201-13 = 2,2 kW
ACT201-15 = 3,0 kW (only 3 ph)
Size 3 ACT201-18 = 4,0 kW (only 3 ph)
ACT201-19 = 5,5 kW (only 3 ph)
Size 4 ACT201-21 = 7,5 kW (only 3 ph)
ACT201-22 = 9,2 kW (only 3 ph)

INVERTER SERIES

ACT201 = inverter ACTIVE 1ph/3ph x 200-240 VAC +/- 10%

Designation

ACT401-15 F A MPSV EMSYS CMCAN KP500

USER INTERFACE

KP500 = programming control unit
KP232 = RS232 serial interface

COMMUNICATION MODULES

CM-CAN = CANopen communication module
CM-PDP = Profibus DP communication module
CM-232 = RS232 serial communication module
CM-485 = RS485 serial communication module

EXPANSION MODULES

EM-SYS = SYSTEMBUS expansion module
EM-IO-xy = I/O expansion modules
EM-ENC-xy = ENCODER expansion modules
EM-RES-xy = RESOLVER expansion modules

INSTALLATION COMPONENTS

MPSV = thru-type mechanical installation kit without fan
MDIN = DIN rail mechanical installation kit
MNVIB = antivibration mechanical installation kit

CONSTRUCTION STYLE

A = style with standard cooling
C = style with cold-plate cooling

EMI FILTER

F = internal filter
- = no internal filter

SIZE

Size 1 ACT401-05 = 0.55 kW
ACT401-07 = 0.75 kW
ACT401-09 = 1.1 kW
ACT401-11 = 1.5 kW
Size 2 ACT401-12 = 1.85 kW
ACT401-13 = 2.2 kW
ACT401-15 = 3.0 kW
ACT401-18 = 4.0 kW
Size 3 ACT401-19 = 5.5 kW
ACT401-21 = 7.5 kW
ACT401-22 = 9.2 kW
Size 4 ACT401-23 = 11 kW
ACT401-25 = 15 kW
Size 5 ACT401-27 = 18.5 kW
ACT401-29 = 22 kW
ACT401-31 = 30 kW
Size 6 ACT401-33 = 37 kW
ACT401-35 = 45 kW
ACT401-37 = 55 kW
ACT401-39 = 65 kW
Size 7 ACT401-43 = 75 kW
ACT401-45 = 90 kW
ACT401-47 = 110 kW
ACT401-49 = 132 kW

INVERTER SERIES

ACT401 = inverter ACTIVE 3ph x 360-480VAC +/- 10%

Technical features

Power range up to 9.2 kW / 200-240 V three phase and 2.2 kW / 200-240 V single phase ^(*)

Designation

ACT201

Size

From 0.55 to 1.1 kW / from 1.5 to 3.0 kW / from 4 to 5.5 kW / from 7.5 to 9.2 kW

Basic equipment

- 200 – 240 V single-phase and three-phase ($\pm 10\%$) / 50 – 60 Hz ($\pm 10\%$)
- TN and IT mains compatible
- overload capacity: 150% for 60s, 200% for 1s
- switching frequency 2 to 16 kHz
- integral EMI filter to EN 61800-3
- speed sensor connection
- integral braking transistor
- DC link connection
- plug-in power terminals up to 4 kW
- plug-in programmable control terminals
- 6 digital inputs, 1 multifunction input
- 1 digital output, 1 multifunction output
- relay output
- freely selectable motor control:
sensorless control, sensorless field-oriented control,
field-oriented control with speed sensor
- additional control and application systems available on request
- motor temperature monitoring
- Standard installation kit

Versions

Cold-plate finish on request

Expansions

- | | |
|-------------|--|
| • KP500 | Removable control unit with parameter copy function |
| • KP232 | Removable RS232 interface adapter |
| • CM-232 | RS232 interface |
| • CM-485 | RS485 interface |
| • CM-CAN | CANopen interface |
| • CM-PDP | Profibus-DP interface |
| • EM-I/O-01 | I/O expansion (3xDI, 1xAI DC ± 10 V, 1xAO DC ± 10 V, 2xRelay, SYSTEMBUS) |
| • EM-I/O-02 | I/O expansion (3xDI, 1xAI DC ± 10 V, 1xAO DC ± 10 V, 1xPTC, 1xRelay, SYSTEMBUS) |
| • EM-I/O-03 | I/O expansion (2xDI, 1xAI DC ± 10 V, 1xAO DC ± 10 V, 1xAO 0-20 mA, 1xRelay, 1xPTC, SYSTEMBUS) |
| • EM-I/O-04 | I/O expansion (1xDI/DO, 2xDI (PNP/NPN), 1xPTC/KTY, SYSTEMBUS) |
| • EM-ENC-01 | Expansion for Line Driver Incremental Speed Sensor at DC 5 V (input signals A, \bar{A} , B, \bar{B} , speed sensor signals repetition FFA, \overline{FFA} , FFB, \overline{FFB} , 1xAI DC ± 10 V, SYSTEMBUS) |
| • EM-ENC-02 | Expansion for Line Driver Incremental Speed Sensor at DC 5 V (input signals A, \bar{A} , B, \bar{B} , 1xDI/DO, 1xAI DC (± 10 V/ ± 20 mA), 1xAO DC 0/4-20 mA, PTC, SYSTEMBUS) |

Power range up to 9.2 kW / 200-240 V three phase and 2.2 kW / 200-240 V single phase^(*)

Technical features

Expansions

- EM-ENC-03 Expansion for Line Driver Incremental Speed Sensor (input signals A, \bar{A} , B, \bar{B} , SYSTEMBUS). Speed sensor external power supply
- EM-ENC-04 Expansion for Line Driver Incremental Speed Sensor at 5 V or 24 V with zero signal (input signals A, \bar{A} , B, \bar{B} , Z, \bar{Z}) 1xAI DC \pm 10 V, 1xAO DC \pm 10 V, 1xRelay
- EM-ENC-05 Expansion for Line Driver Incremental Speed Sensor at 5 V or 24 V with zero signal (input signals A, \bar{A} , B, \bar{B} , Z, \bar{Z}) 1xAI DC \pm 10 V, 1xAO DC \pm 10 V, SYSTEMBUS
- EM-RES-01 Expansion for Resolver (input signals SIN, COS, REF resolver power supply, repetition frequency output FFA, \overline{FFA} , FFB, \overline{FFB} , 1xAI (DC \pm 10 V/ \pm 20 mA)), SYSTEMBUS
- EM-RES-02 Expansion for Resolver (input signals SIN, COS, REF resolver power supply, repetition frequency output FFA, \overline{FFA} , FFB, \overline{FFB} , frequency reference signal, 1xAI (DC \pm 10 V/ \pm 20 mA))
- EM-SYS SYSTEMBUS expansion

Development tools

- VPlus Software for inverter programming and monitoring on PC with Windows operating system. Oscilloscope Function with 4 programmable traces

Accessories

- Installation kit Various mechanical installation kits (MPSV, MPVIB, MDIN) for different types of enclosure mounting solutions
- Line choke Input filter for reducing current harmonics
- EMI filter Input filter for EMC regulation compliance
- dV/dt filter Output filter for dV/dt attenuation
- Sine wave filter Output filter for long inverter/motor cable
- Mains unit PFC and network recovery of regeneration energy
- Braking Resistor External resistor for dynamic braking

6 **Active 401/201** **ACT401-05 ... ACT401-49 series**

Technical features

Power range up to 132 kW / 360-480 V three-phase

Designation

ACT401

Size

From 0.55 to 1.5 kW / from 1.85 to 4.0 kW / from 5.5 to 9.2 kW / from 11 to 15 kW / from 18.5 to 30 kW / from 37 to 65 kW / from 75 to 132 kW

Basic equipment

- 360 - 480 V three-phase ($\pm 10\%$) / 50 - 60 Hz ($\pm 10\%$)
- TN and IT mains capable
- overload capacity: 150% for 60s, 200% for 1s
- switching frequency 2 to 16 kHz
- integral EMI filter to EN 61800-3 up to 7.5 kW
- speed sensor connection
- motor temperature monitoring
- integral braking transistor
- DC link connection
- plug-in power terminals up to 4 kW
- plug-in programmable control terminals
- 6 digital inputs, 1 multifunction input
- 1 digital output, 1 multifunction output
- relay output
- freely selectable motor control system:
sensorless control, sensorless field-oriented control,
field-oriented control with speed sensor
- additional control and application systems available on request
- Standard installation kit

Versions

Cold-plate finish on request

Expansions

- | | |
|--|---|
| <ul style="list-style-type: none"> • KP500 • KP232 | <p>Removable control unit with parameter copy function</p> <p>Removable RS232 interface adapter</p> |
| <ul style="list-style-type: none"> • CM-232 • CM-485 • CM-CAN • CM-PDP | <p>RS232 interface</p> <p>RS485 interface</p> <p>CANopen interface</p> <p>Profibus-DP interface</p> |
| <ul style="list-style-type: none"> • EM-I/O-01 • EM-I/O-02 • EM-I/O-03 • EM-I/O-04 | <p>I/O expansion (3xDI, 1xAI DC ± 10 V, 1xAO DC ± 10 V, 2xRelay, SYSTEMBUS)</p> <p>I/O expansion (3xDI, 1xAI DC ± 10 V, 1xAO DC ± 10 V, 1xPTC, 1xRelay, SYSTEMBUS)</p> <p>I/O expansion (2xDI, 1xAI DC ± 10 V, 1xAO ± 10 V, 1xAO DC 0-20 mA, 1xRelay, 1xPTC, SYSTEMBUS)</p> <p>I/O expansion (1xDI/DO, 2xDI (PNP/NPN), 1xPTC/KTY, SYSTEMBUS)</p> |
| <ul style="list-style-type: none"> • EM-ENC-01 • EM-ENC-02 | <p>Expansion for Line Driver Incremental Speed Sensor at DC 5 V (input signals A, \bar{A}, B, \bar{B}, speed sensor signals repetition FFA, FF\bar{A}, FFB, FF\bar{B}, 1xAI DC ± 10 V, SYSTEMBUS)</p> <p>Expansion for Line Driver Incremental Speed Sensor at DC 5 V (input signals A, \bar{A}, B, \bar{B}, 1xDI/DO, 1xAI DC (± 10 V/± 20 mA), 1xAO DC 0/4-20 mA, PTC, SYSTEMBUS)</p> |

Power range up to 132 kW / 360-480 V three-phase

Technical features

Expansions

- EM-ENC-03 Expansion for Line Driver Incremental Speed Sensor (input signals A, \bar{A} , B, \bar{B} , SYSTEMBUS). Speed sensor external power supply
- EM-ENC-04 Expansion for Line Driver Incremental Speed Sensor at 5 V or 24 V with zero signal (input signals A, \bar{A} , B, \bar{B} , Z, \bar{Z}) 1xAI DC \pm 10 V, 1xAO DC \pm 10 V, 1xRelay
- EM-ENC-05 Expansion for Line Driver Incremental Speed Sensor at 5 V or 24 V with zero signal (input signals A, \bar{A} , B, \bar{B} , Z, \bar{Z}) 1xAI DC \pm 10 V, 1xAO DC \pm 10 V, SYSTEMBUS
- EM-RES-01 Expansion for Resolver (input signals SIN, COS, REF resolver power supply, repetition frequency output FFA, \overline{FFA} , FFB, \overline{FFB} , 1xAI (DC \pm 10 V/ \pm 20 mA)), SYSTEMBUS
- EM-RES-02 Expansion for Resolver (input signals SIN, COS, REF resolver power supply, repetition frequency output FFA, \overline{FFA} , FFB, \overline{FFB} , frequency reference signal, 1xAI (DC \pm 10 V/ \pm 20 mA))
- EM-SYS SYSTEMBUS expansion

Development tools

- VPlus Software for inverter programming and monitoring on PC with Windows operating system. Oscilloscope Function with 4 programmable traces

Accessories

- Installation kit Various mechanical installation kits (MPSV, MPVIB, MDIN) for different types of enclosure mounting solutions
- Line choke Input filter for reducing current harmonics
- EMI filter Input filter for EMC regulation compliance
- dV/dt filter Output filter for dV/dt attenuation
- Sine wave filter Output filter for long inverter/motor cable
- Mains unit PFC and network recovery of regeneration energy
- Braking Resistor External resistor for dynamic braking

Technical features

Hardware

- Range of voltage area:
200 – 240 V single-phase and three-phase ($\pm 10\%$), 360 – 480 V three-phase ($\pm 10\%$)
- TN and IT mains capable thanks to adaptation of basic devices
- Integral EMI filter to EN 61800-3 on devices up to 9.2 kW
- DC link bus for energy exchange and central power feeding
- Plug-in power terminals up to 4 kW
- Plug-in control terminals: ensures easy connection and separation of control terminals
- Multifunction input: ensures high flexibility in defining the reference value using a range of different signal sources
- Connection of digital inputs to software modules in the form of logic signals
- Multifunction output selectable from among a vast range of parameters
- Facility to connect digital outputs and relay output to the software modules for programming requirements
- Motor overtemperature protection by means of thermo-evaluation
- Speed sensor input for high dynamics applications requiring high precision speed and torque control
- Integral braking transistor to limit DC bus voltage in braking operation
- Folding type attachment for extremely compact installation
- DIN rail installation facility for units up to 4 kW
- Lateral installation facility for units up to 4 kW
- Construction with high IP protection ratings thanks to Cold-Plate option
- Supports master / slave operation in basic version for electronic gear applications and similar
- Optional expansion modules to extend control inputs and outputs
- Optional encoder modules to evaluate TTL & HTL encoder and Resolver
- Optional communication modules to connect to standard field bus networks and point-to-point connections
- KP500 control unit with copy function to facilitate parameterisation and control operations
- KP232 interface adapter for high communication flexibility via a serial protocol

Technical features

Software

- Selectable motor control system:
 - sensorless control
 - sensorless field-oriented control
 - field-oriented control with speed sensor (FOC)
 - brushless motor
- Coupling with various reference value sources on reference frequency channel and reference percentage channel
- Intelligent current limits for load-dependant optimisation of operational behaviour
- Mains voltage monitoring enables programmable behaviour in the event of faults
- Use of kinetic energy in the drive system for power failure bridging or controlled motor stopping in mains power loss conditions
- Motor phase monitoring to avoid stressing the coupled load
- Speed sensor monitoring with continuous control of sensor signals
- Overload protection and automatic switching frequency adaptation
- Motor circuit breaker for protection of the connected motor
- Motor chopper function (reduces braking energy without brake unit)
- Programmable starting and stopping behaviour so the drive can be started, stopped, and controlled down to standstill
- S-ramp for separately adjustable acceleration and deceleration ramps and for smooth speed changes (jerk limitation)
- Motor potentiometer controlled via digital input, control unit and communication interface
- Four data sets for parameterisation of various operational behaviour modes
- Parameter identification of the connected motor (tuning) as a supplementary facility of the guided commissioning function
- Auto set-up of dependent parameters during guided commissioning procedure
- Synchronization function to catch a spinning motor
- Auto-start after alarm or power loss
- Automatic acknowledgement of selected faults without motor switch-off (pre-alarm)
- Integrated PI control let to implement (for example) pressure, volumetric flow or speed control (with tacho generator)
- Brake Control and Load Detection for lifting applications
- Programmable timer and logical functions included in the software modules
- Flow control to optimise operational behaviour
- Continuous torque monitoring for control of drive behaviour under load
- Surge-free speed / torque control switch-over
- System bus for transmission of parameter settings, actual and nominal values
- Positioning from reference point with programmable stopping behaviour
- Stability control in synchronous tie applications
- Memory of real mean and peak values
- Alarms video page and report generation with adjustable limits and behaviour responses
- Alarm memory and environment

10 **Active 401/201** ACT201-05 ... ACT201-15 series

Technical data

(from 0.55 to 3.0 kW)

INVERTER

				Size 1			Size 2		
				ACT201-05	ACT201-07	ACT201-09	ACT201-11	ACT201-13	ACT201-15
				F			F		
				A or C			A or C		
Output, motor side	Recommended rated motor power	P _n	kW	0.55	0.75	1.1	1.5	2.2	3.0
	Rated motor current output	I _n	A	3.0	4.0	5.5	7.0	9.5	12.5
	Rated motor voltage output	U _n	V	3 x (from 0 to mains voltage)					
	Overload current for 60 s	I _{pk}	A	4.5	6.0	7.3	10.5	14.3	16.2
	Overload current for 1 s	I _{pk}	A	6.0	8.0	8.0	14.0	19.0	19.0
	Switching frequency	f _c	kHz	From 2 to 16					
	Rated motor frequency	f _n	Hz	From 0 to 1000					
Input, mains side	Nominal mains voltage	U	V	184 ... 264					
	Nominal mains frequency	f	Hz	45 ... 66					
	Nominal current 3 ph/PE	I	A	3.0	4.0	5.5	7.0	9.5	10.5
	Nominal current 1 ph/N/PE; 2 ph/PE	I	A	5.4	7.2	9.5	13.2	16.5	16.5
	EMI filter	-	-	Built-in					
General	Short circuit / ground fault protection	-	-	Yes, unlimited					
	Mounting position	-	-	Vertical					
	Protection class	-	-	IP 20 (EN60529)					
	Dimensions Std. A	HxWxD	mm	190 x 60 x 175			250 x 60 x 175		
	Cold Plate Opt. C	HxWxD	mm	190 x 82 x 140			250 x 85 x 140		
	Weight (approx.)	m	kg	1.2			1.6		
	Environment	Cooling temperature	T _n	°C	From 0 to 40 (3K3 DIN IEC 721-3-3)				
Relative air humidity		-	%	From 15 to 85, non-condensing					
Derating		P	-	2,5%/K above 40°C; T _{max} = 55°C; 5%/1000m above 1000m installation altitude; h _{max} = 4000m					
Options & accessories	Line choke	-	-	external (depending on mains supply)					
	EMI filter	-	-	internal (EN 61800-3); external					
	Brake unit	-	-	internal brake transistor					
	Digital control unit	-	-	yes					

(from 4.0 to 9.2 kW)

Technical data

INVERTER				Size 3		Size 4	
				ACT201-18	ACT201-19	ACT201-21	ACT201-22
				- or F		-	
				A or C		A or C	
Output, motor side	Recommended rated motor power	P _n	kW	4.0	5.5	7.5	9.2
	Rated motor current output	I _n	A	18.0	22.0	32.0	35.0
	Rated motor voltage output	U _n	V	3 x (from 0 to mains voltage)			
	Overload current for 60 s	I _{pk}	A	26.2	30.3	44.5	51.5
	Overload current for 1 s	I _{pk}	A	33.0	33.0	64.0	64.0
	Switching frequency	f _c	kHz	From 2 to 16			
	Rated motor frequency	f _n	Hz	From 0 to 1000			
Input, mains side	Nominal mains voltage	U	V	184 ... 264			
	Nominal mains frequency	f	Hz	45 ... 66			
	Nominal current 3 ph/PE	I	A	18	20	28.2	35.6
	Mains fuses 3 ph/PE	I	A	25		35	50
General	Short circuit / ground fault protection	-	-	Yes, unlimited			
	Mounting position	-	-	Vertical			
	Protection class	-	-	IP 20 (EN60529) ⁽⁰⁾			
	Dimensions Std. A	HxWxD	mm	250 x 100 x 200		250 x 125 x 200	
	Cold Plate Opt. C	HxWxD	mm	—			
	Weight (approx.)	m	kg	3.0		3.7	
Environment	Cooling temperature	T _n	°C	From 0 to 40 (3K3 DIN IEC 721-3-3)			
	Relative air humidity	-	%	From 15 to 85, non-condensing			
	Derating	P	-	2.5%/K above 40 °C; Tmax = 55 °C; 5%/1000 m above 1000 m installation altitude; hmax = 4000m			
Options & accessories	Line choke	-	-	external (depending on mains supply)			
	EMI filter	-	-	internal (EN 61800-3); external (see table on page 48)			
	Brake unit	-	-	internal brake transistor			
	Digital control unit	-	-	yes			

Note: (0) = for protection classes higher than IP20 consult your local Bonfiglioli Drives Service Center

12 **Active 401/201** ACT401-05 ... ACT401-15 series

Technical data

(from 0.55 to 3.0 kW)

INVERTER				Size 1				Size 2		
				ACT401-05	ACT401-07	ACT401-09	ACT401-11	ACT401-12	ACT401-13	ACT401-15
				F				F		
				A or C				A or C		
Output, motor side	Recommended rated motor power	P _n	kW	0.55	0.75	1.1	1.5	1.85	2.2	3.0
	Rated motor current output	I _n	A	1.8	2.4	3.2	3.8	4.2	5.8	7.8
	Rated motor voltage output	U _n	V	3 x (from 0 to mains voltage)						
	Overload current for 60 s	I _{pk}	A	2.7	3.6	4.8	5.7	6.3	8.7	11.7
	Overload current for 1 s	I _{pk}	A	3.6	4.8	6.4	7.6	8.4	11.6	15.6
	Switching frequency	f _c	kHz	From 2 to 16						
	Rated motor frequency	f _n	Hz	From 0 to 1000						
Input, mains side	Nominal mains voltage	U	V	320 ... 528						
	Nominal mains frequency	f	Hz	45 ... 66						
	Nominal current 3 ph/PE	I	A	1.8	2.4	2.8	3.3	4.2	5.8	6.8
	Mains fuses 3 ph/PE	I	A	6				10		
General	Short circuit / ground fault protection	-	-	Yes, unlimited						
	Mounting position	-	-	Vertical						
	Protection class	-	-	IP 20 (EN60529) ⁽⁰⁾						
	Dimensions Std. A	HxWxD	mm	190 x 60 x 175				250 x 60 x 175		
	Cold Plate Opt. C	HxWxD	mm	190 x 82 x 140				250 x 85 x 140		
	Weight (approx.)	m	kg	1.2				1.6		
Environment	Cooling temperature	T _n	°C	From 0 to 40 (3K3 DIN IEC 721-3-3)						
	Relative air humidity	-	%	From 15 to 85, non-condensing						
	Derating	P	-	2.5%/K above 40 °C; Tmax = 55 °C; 5%/1000 m above 1000 m installation altitude; hmax = 4000m						
Options & accessories	Line choke	-	-	external (depending on mains supply)						
	EMI filter	-	-	internal (EN 61800-3); external (see table on page 48)						
	Brake unit	-	-	internal brake transistor						
	Digital control unit	-	-	yes						

Note: (0) = for protection classes higher than IP20 consult your local Bonfiglioli Drives Service Center

(from 4.0 to 15 kW)

Technical data

INVERTER				Size 2	Size 3			Size 4		
				ACT401-18	ACT401-19	ACT401-21	ACT401-22	ACT401-23	ACT401-25	
				F	- or F			-		
				A2 or C2	A or C			A or C		
Output, motor side	Recommended rated motor power	P_n	kW	4.0	5.5	7.5	9.2	11.0	15.0	
	Rated motor current output	I_n	A	9.0	14.0	18.0	22.0	25.0	32.0	
	Rated motor voltage output	U_n	V	3 x (from 0 to mains voltage)						
	Overload current for 60 s	I_{pk}	A	13.5	21.0	26.3	30.3	37.5	44.5	
	Overload current for 1 s	I_{pk}	A	18.0	28.0	33.0	33.0	50.0	64.0	
	Switching frequency	f_c	kHz	From 2 to 16						
	Rated motor frequency	f_n	Hz	From 0 to 1000						
Input, mains side	Nominal mains voltage	U	V	320 ... 528						
	Nominal mains frequency	f	Hz	45 ... 66						
	Nominal mains current 3 ph/PE	I	A	7.8	14.2	15.8	20.0	26.0	28.2	
	Mains fuses 3ph/PE	I	A	10.0	16.0	25.0		35.0		
General	Short circuit / ground fault protection	-	-	Yes, unlimited						
	Mounting position	-	-	Vertical						
	Protection class	-	-	IP 20 (EN60529) ⁽⁰⁾						
	Dimensions Std. A	HxWxD	mm	250 x 60 x 175			250 x 100 x 200		250 x 125 x 200	
	Cold Plate Opt. C	HxWxD	mm	250 x 85 x 140			250 x 125 x 144		250 x 150 x 144	
	Weight (approx.)	m	kg	1.6			3.0		3.7	
	Environment	Cooling temperature	T_n	°C	From 0 to 40 (3K3 DIN IEC 721-3-3)					
Relative air humidity		-	%	From 15 to 85, non-condensing						
Derating		P	-	2.5%/K above 40 °C; Tmax = 55 °C; 5%/1000 m above 1000 m installation altitude; hmax = 4000 m						
Options & accessories	Line choke	-	-	external (depending on mains supply)						
	EMI filter	-	-	internal (EN 61800-3); external				external		
	Brake unit	-	-	internal brake transistor						
	Digital control unit	-	-	yes						

Note: (0) = for protection classes higher than IP20 consult your local Bonfiglioli Drives Service Center

14 **Active 401/201** ACT401-27 ... ACT401-31 series

Technical data

(from 18.5 to 30 kW)

INVERTER

				Size 5		
				ACT401-27	ACT401-29	ACT401-31
				-		
				A or C		
Output, motor side	Recommended rated motor power	P_n	kW	18.5	22.0	30.0
	Rated motor current output	I_n	A	40.0	45.0	60.0
	Rated motor voltage output	U_n	V	3 x (from 0 to mains voltage)		
	Overload current for 60 s	I_{pk}	A	60.0	67.5	90.0
	Overload current for 1 s	I_{pk}	A	80.0	90.0	120.0
	Switching frequency	f_c	kHz	From 2 to 8		
	Rated motor frequency	f_n	Hz	From 0 to 1000		
Input, mains side	Nominal mains voltage	U	V	320 ... 528		
	Nominal mains frequency	f	Hz	45 ... 66		
	Nominal mains current 3 ph/PE	I	A	35.6	52.0	58.0
	Mains fuses 3ph/PE	I	A	50.0		63.0
General	Short circuit / ground fault protection	-	-	Yes, unlimited		
	Mounting position	-	-	Vertical		
	Protection class	-	-	IP 20 (EN60529) ⁽⁰⁾		
	Dimensions Std. A	HxWxD	mm	250 x 200 x 260		
	Cold Plate Opt. C	HxWxD	mm	250 x 225 x 171		
	Weight (approx.)	m	kg	8.0		
Environment	Cooling temperature	T_n	°C	From 0 to 40 (3K3 DIN IEC 721-3-3)		
	Relative air humidity	-	%	From 15 to 85, non-condensing		
	Derating	P	-	2.5%/K above 40 °C; Tmax = 55 °C; 5%/1000 m above 1000 m installation altitude; hmax = 4000 m		
Options & accessories	Line choke	-	-	external (depending on mains supply)		
	EMI filter	-	-	external		
	Brake unit	-	-	internal brake transistor		
	Digital control unit	-	-	yes		

Note: (0) = for protection classes higher than IP20 consult your local Bonfiglioli Drives Service Center

(from 37 to 65 kW)

Technical data

INVERTER				Size 6			
				ACT401-33	ACT401-35	ACT401-37	ACT401-39
				A			
Output, motor side	Recommended rated motor power	P_n	kW	37.0	45.0	55.0	65.0
	Rated motor current output	I_n	A	75.0	90.0	110.0	125.0
	Rated motor voltage output	U_n	V	3 x (from 0 to mains voltage)			
	Overload current for 60 s	I_{pk}	A	112.5	135.0	165.0	187.5
	Overload current for 1 s	I_{pk}	A	150.0	180.0	220.0	250.0
	Switching frequency	f_c	kHz	From 2 to 8			
	Rated motor frequency	f_n	Hz	From 0 to 1000			
Input, mains side	Nominal mains voltage	U	V	320 ... 528			
	Nominal mains frequency	f	Hz	45 ... 66			
	Nominal mains current 3 ph/PE	I	A	72	86	105	120
	Mains fuses 3ph/PE	I	A	80	100	125	125
General	Short circuit / ground fault protection	-	-	Yes, unlimited			
	Mounting position	-	-	Vertical			
	Protection class	-	-	IP 20 (EN60529) ⁽⁰⁾			
	Dimensions Std. A	HxLxP	mm	400 x 275 x 260			
	Cold Plate Opt. C	HxLxP	mm	—			
	Weight (approx.)	m	kg	20			
Environment	Cooling temperature	T_n	°C	From 0 to 40 (3K3 DIN IEC 721-3-3)			
	Relative air humidity	-	%	From 15 to 85, non-condensing			
	Derating	P	-	2.5%/K above 40 °C; Tmax = 55 °C; 5%/1000 m above 1000 m installation altitude; hmax = 4000 m			
Options & accessories	Line choke	-	-	external (depending on mains supply)			
	EMI filter	-	-	external			
	Brake unit	-	-	internal brake transistor			
	Digital control unit	-	-	yes			

Note: (0) = for protection classes higher than IP20 consult your local Bonfiglioli Drives Service Center

16 **Active 401/201** ACT401-43 ... ACT401-49 series

Technical data

(from 75 to 132 kW)

INVERTER

Size 7

ACT401-43	ACT401-45	ACT401-47	ACT401-49
-----------	-----------	-----------	-----------

A

				ACT401-43	ACT401-45	ACT401-47	ACT401-49
Output, motor side	Recommended rated motor power	P_n	kW	75.0	90.0	110.0	132.0
	Rated motor current output	I_n	A	150.0	180.0	210.0	250.0
	Rated motor voltage output	U_n	V	3 x (from 0 to mains voltage)			
	Overload current for 60 s	I_{pk}	A	225.0	270.0	315.0	332.0
	Overload current for 1 s	I_{pk}	A	270.0	325.0	375.0	375.0
	Switching frequency	f_c	kHz	From 2 to 8			
	Rated motor frequency	f_n	Hz	From 0 to 1000			
Input, mains side	Nominal mains voltage	U	V	320 ... 528			
	Nominal mains frequency	f	Hz	45 ... 66			
	Nominal mains current 3 ph/PE	I	A	143	172	208	249
	Mains fuses 3ph/PE	I	A	160	200	250	315
General	Short circuit / ground fault protection	-	-	Yes, unlimited			
	Mounting position	-	-	Vertical			
	Protection class	-	-	IP 20 (EN60529) ⁽⁰⁾			
	Dimensions Std. A	HxLxP	mm	510 x 412 x 351			
	Cold Plate Opt. C	HxLxP	mm	—			
	Weight (approx.)	m	kg	45		48	
Environment	Cooling temperature	T_n	°C	From 0 to 40 (3K3 DIN IEC 721-3-3)			
	Relative air humidity	-	%	From 15 to 85, non-condensing			
	Derating	P	-	2.5%/K above 40 °C; Tmax = 55 °C; 5%/1000 m above 1000 m installation altitude; hmax = 4000 m			
Options & accessories	Line choke	-	-	external (depending on mains supply)			
	EMI filter	-	-	external			
	Brake unit	-	-	optional internal brake transistor			
	Digital control unit	-	-	yes			

Choosing the product size with the ACT 401/201 series is even simpler: one model for each motor power size.
In addition, the new sizes correspond perfectly to the motor sizes in the BONFIGLIOLI range.



ACT401-21 FA



7.5 kW motor



Installation altitude

Power supply reduction (derating):
5%/1000 m a.s.l.; $h_{max} = 4000$ m

Max. cooling temperature
3.3°C/1000 m above 1000 m a.s.l.

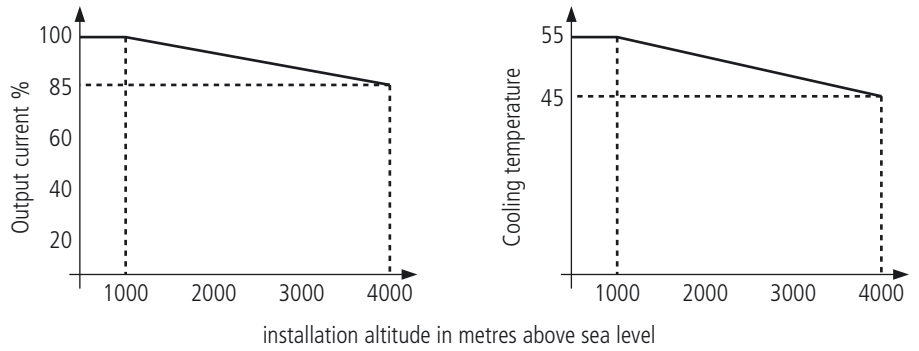

Cooling temperature

Derating in relation to installation temperature 2.5%/K above 40°C; $T_{max} = 55$ °C

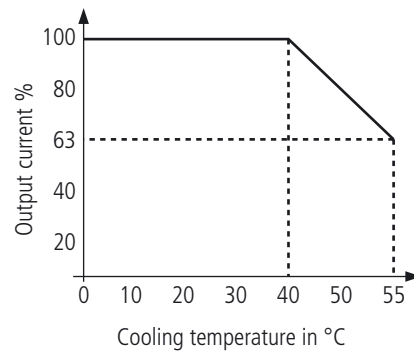

Mains voltage

Derating in relation to power feeding voltage 0.22%/V beyond 400V; $V_{max} = 480$ V

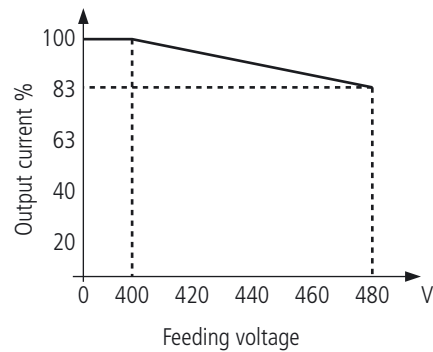

Optional components

Thanks to the modularity of their hardware components, ACTIVE frequency inverters are easily integrated in automation applications. Optional on-board modules are automatically recognised by the inverter when present (plug and play) right from the initialisation phase, and the internal control functions of the unit are automatically adapted accordingly. The modules available for connector **A** (see figure) can be plugged into the inverter directly, while the cover must be removed in order to gain access to plug-in sections **B** and **C**. If a communication module is added to section **B** the perforated part of the cover must be eliminated. Further information on installation and management of the optional modules is given in the specific documentation (optional equipment user handbooks).

A Interface module

Connection of optional control unit KP500, serial interface adapter KP232, or the control unit remotisation cable for accessory KPCMK

B CM communication module

Connection panel for various communication protocols:

- CM-232, RS232 interface
- CM-485, RS485 interface
- CM-PDP, Profibus-DP interface
- CM-CAN, CANopen interface
- Other protocols on request

C EM expansion module

Connection panel for adaptation of control inputs and outputs to the various applications on the basis of specific customer requirements:

- EM-IO, analog and digital inputs and outputs, available in 4 variants
- EM-ENC, speed sensor interface, frequency output and system bus, available in 5 variants
- EM-RES, resolver interface, frequency output and system bus, available in 2 variants
- EM-SYS, system bus for Systembus communication
(On request, system bus combined with CM-CAN communication module)
- Other personalisable modules on request

A single module at a time taken from each corresponding list can be installed in each location (A, B, C). The modules of each seat are compatible with those of the other two, with the exception of CM-CAN and EM-SYS, which cannot be installed together on the same inverter. KP232 and CM-232 are two RS232 serial interfaces accommodated in different locations. The two interfaces are mutually compatible but feature different communication speeds. Only KP232 is compatible with the use of the Oscilloscope function forming part of the VPlus management software.

Hardware modularity

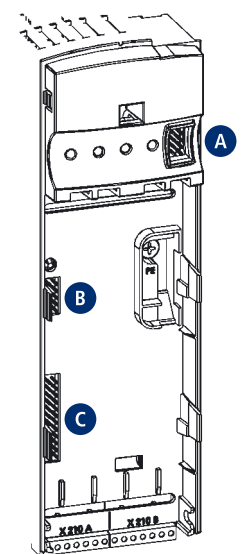

Control unit / KP500



The KP500 control unit is equipped with a Parameters Copy function that allows the user to upload parametric values from the inverter to a non-volatile memory installed in the KP500 device, allowing the same values to be subsequently downloaded to another inverter.

The control unit makes it possible to set up the inverter for specific applications and allows the display of the service values of physical and electrical parameters.

The inverter can also be controlled from the control unit for start/stop and frequency reference increase/decrease commands. Since the control unit is not indispensable for inverter operation it can be connected exclusively when the user considers it useful or necessary.

Technical data

Dimensions (mm)	LxWxD	60 x 75 x 35
Weight	m	50 g
Operating temperature	T	-10°C ... +60°C
Storage temperature	T	-20°C ... +70°C

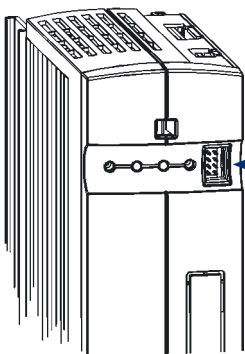
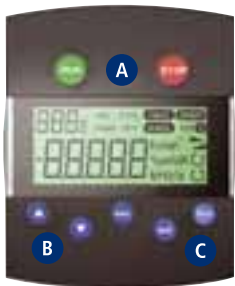

RUN

Starts the drive and opens CTRL menu.
Press RUN to go to the motor potentiometer function.

STOP

Opens the CTRL menu and stops the drive. Error reset.

A

Navigation through the menus and selection of parameters.
Increases or reduces parametric values

B

ENT

Retrieves parameters or makes changes in the menu structure.
Confirms selected function or parameter.

ESC

Abandons parameters or returns to menu structure.
Cancels function or resets parametric value.

FUN

Switches key function and provides access to special functions.

C

Control unit remote installation kit / KPCMK

The KPCMK kit is used to mount the unit KP500 remotely from the inverter.



Handheld remote control unit

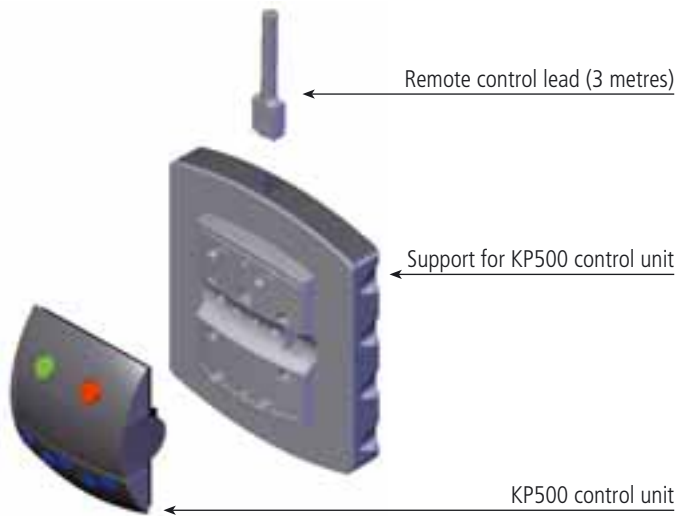

Remote installation on exterior of enclosure

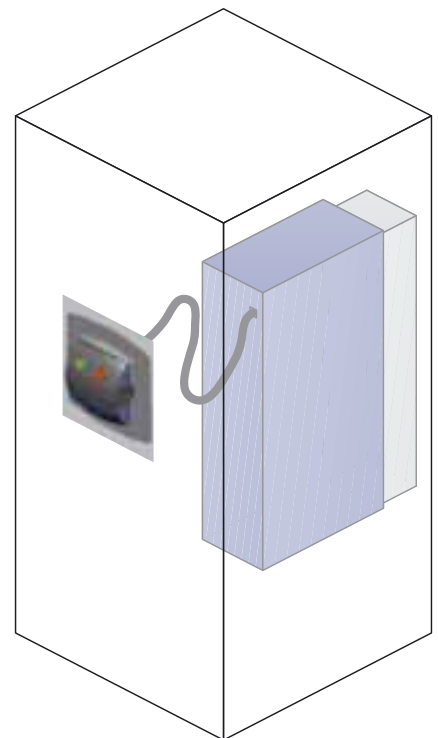

Fixing to enclosure

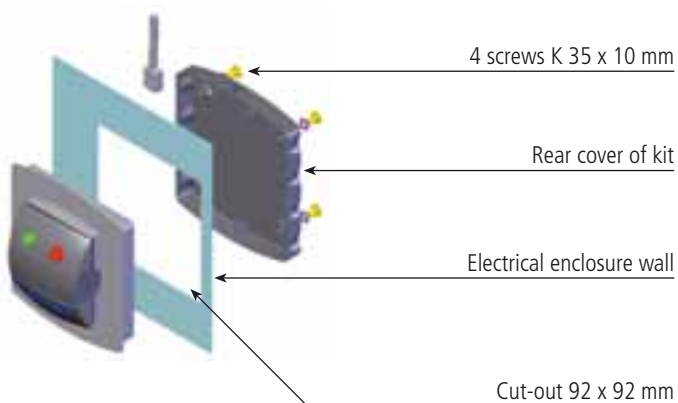

Interface / KP-232



Serial interface KP232 can be used as an alternative to control unit KP500. This connection enables parameterisation, monitoring, setting management, inverter control and even commissioning from a PC or laptop computer. The serial point-to-point connection between inverter and PC complies with specifications for transmission between data terminals (DTE) and data communication equipment (DCE), requiring, in this mode, a serial pin-to-pin cable with DB9 male connector on the inverter side.

The KP232 interface is compatible with lines no longer than 15 metres. The serial transmission protocol ensures high data security and does not require handshake signals between computer and inverter.

The VPlus software application can be supplied as an accessory. This program, which runs in Windows, is dedicated to the complete management of the ACTIVE inverter from a PC, including the functions of commissioning and parameterisation, which calls for the presence of hardware interface KP232, CM232 or CM485. The VPlus package also includes a digital Oscilloscope Function. The oscilloscope has four traces configurable for inverter monitoring also with graphic capabilities.

Technical data

Baud rate (kBaud)

Up to 115.2 kb

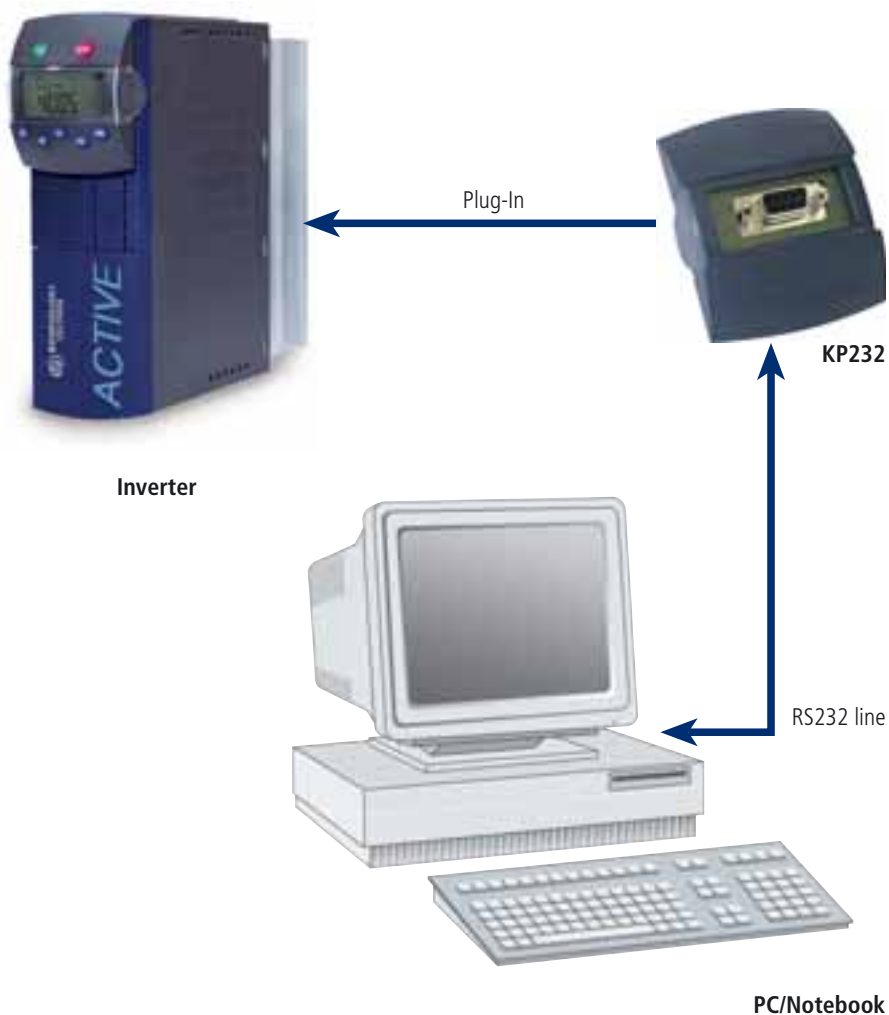

RS232 / CM-232 serial communication

The optional CM-232 communication card enables RS232 serial connection of the ACTIVE inverter to an external control device or PC to ANSI standard EIA/TIA-232E and CCITT V.28. The standard defines the electrical and mechanical characteristics of serial connections between data terminating equipment (DTE) and data communication equipment (DCE).

The serial interface, in the form of a DB9 plug, features DCE type pinouts.

The serial transmission protocol guarantees high data security and allows connection, also without handshake signals, thereby reducing the required number of connection lines to just three.

As in all transmission processes, the maximum permissible distance between the various bus subscribers (inverters) and the master (PC, PLC) depends on the cable used and the selected transmission rate. Also this option can be supplied with the VPlus application for inverter programming and monitoring. Unlike the KP232, the CM232 does not support the oscilloscope function incorporated in the VPlus package, since the baud rate is restricted to 19.2 kb.



Accommodation
of CM-232 module
on the frequency inverter



PC/Notebook

Technical data	
Baud rate (kBaud)	2,4
	4,8
	9,6
	19,2

If a transmission rate of 9.6 kBaud or higher is selected the line must be no longer than 30 metres.

RS485 / CM-485 serial and modbus communication



Accommodation of CM-485 module on the frequency inverter

Serial communication

The CM-485 communication card is designed for the transmission of serial data at high speed over long distances in industrial applications. The RS485 bus supports data transmission among 30 subscribers in a bi-directional two-wire system.

The interface is implemented on a DB9 connector. Physical transmission of data on a 2-wire serial bus complies with standards ITU V.11 and ANSI EIA/TIA-422B. The pinout of the DB9 connector ensures straightforward wiring.

The CM-485 communication card also contains a 150 Ω burden resistor for network termination, which can be activated by means of an on-board dipswitch. The standard interface allows an address node limit of a maximum of 30 inverters on the network bus. The RS485 network address of the inverter is programmed by means of software parameters via the KP500 control unit or by means of serial communication with KP232, which are compatible with the presence of CM485 on board the inverter.

The RS485 transmission protocol complies with ISO standard 1745 for code-bound data transmission. The standard transmission rate and monitoring functions are parameterised by means of the frequency inverter software.

Technical data			
Cable length (m)	2000	Baud rate (kBaud)	2,4
	2000		4,8
	12000		9,6
	12000		19,2

The values given in the table are guideline and are subject to variations in relation to the cable characteristics.

RS485 / CM-485 serial and modbus communication

Modbus communication

The communication module CM-485 allows to use the Modbus Communication profile. The communication profile can be changed to Modbus easily with a parameter. Therefore a very inexpensive solution is available to integrate the ACT inverters in a Modbus Communication environment with the standard ACT devices and a standard module. There are two profiles available. The Modbus RTU profile is well established and known to the experienced Modbus user, which offers quick communication between different devices. Additionally, Modbus ASCII is supported as well, which allows easy set up and diagnosis of the communication between different devices. The address range allows values between 1 to 247.



Accommodation of CM-485 module on the frequency inverter

Technical data

Cable length (m)	2000	Baud rate (kBaud)	2,4
	2000		4,8
	12000		9,6
	12000		19,2

The values given in the table are guideline using a CM485 module and are subject to variations in relation to the cable characteristics.



VPlus for PC



VPlus is a software application for management of Bonfiglioli ACTIVE and VCB inverters using a PC connected to the drive by means of an RS232 or RS485 serial interface.

For this purposes the ACTIVE inverter must be equipped with the optional KP232 interface or with communication module CM232 or CM485.

The program is a highly useful accessory in all phases of the application, from inverter commissioning to run-time monitoring.

The user interface features an ergonomic structure that supports the user during programming, management, and monitoring, allowing storage of data sets by saving them to file and subsequent retrieval for the reverse procedure of downloading to the inverter.

VPlus requires a PC running Windows 98/NT/2000/XP and an RS232 or RS485 standard serial port with DB9 connector, grounded to avoid problems of disturbance on signals exchanged between inverter and computer.

The menus / submenus structure provides subdivision of parameters by uniform groups.

The interface language can be English, Italian, or German.

The VPlus program also provides the facility for modem connection for remote diagnostics operations on the inverter.

OSCILLOSCOPE function

The Oscilloscope Function of the ACTIVE inverter is an application package integrated in the Bonfiglioli VPlus program which, by means of the acquisition of signals arriving from the drive core, enables the graphic representation of both the power and control waveforms for the purposes of field technical diagnosis optimisation of the applications. An essential requirement for the use of the integrated oscilloscope is the installation of interface module KP232 on the inverter. When connected to the PC using a standard DB9 female-female cable this interface creates 115 kbit/s acquisition channels of the four traces shown on the computer screen.

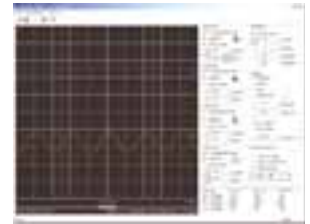

Salient features of the Oscilloscope Function:

- 4 channels
- Display of absolute values
- Amplitude and time measurement cursors
- Timebase from 20 ms/div to 50 s/div
- Various trigger types
- Graphic memory up to 1 Mbyte
- Trace recording memory up to 60 min.
- Sampling times from 2 ms to 32 ms (depending on the PC)
- Various trace storage formats

Minimum inverter requirements:

- ACTIVE with firmware version 4.1.X or higher
- KP232 interface ver. 0204 or more recent

ACTIVE oscilloscope graphic presentation

The functionality and practicality of the virtual oscilloscope are identical to those of a powerful and modern conventional oscilloscope, with the added benefit that all the parameters controlled by the inverter microprocessor can be displayed, whether of a physical nature (current, voltage, frequency, etc.) or a virtual nature (internal control variables, timer signals, comparator signals, internal digital signals, etc.).

DP / CM-PDP Profibus Communication



Internal dipswitch to enable the 220 Ω terminating burden resistor incorporated in the module



Accommodation of module CM-PDP on the frequency inverter

The PROFIBUS DP interface complies with European field bus standard EN50170 and German standard DIN 19245. The PROFIBUS version, which is optimised in order to provide excellent performance in terms of speed and reduced connection costs, has been adapted in a targeted manner for communication between automation systems and decentralised peripheral devices.

The "variable speed drives" profile (PROFIDRIVE) for electrical drives technology identifies five standardised data messages, the so-called parametric process data objects (PPO), which must be previously configured in the Profibus master at the time the GSD file is loaded. The software of the ACTIVE inverter supports types PPO1, PPO2, PPO3 and PPO4.

The CM-PDP interface supports different transmission rates in compliance with EN 50170 standard. The transmission rate is not fixed explicitly, because the Profibus supports the Auto_Baud function, which automatically defines the baud rate set on the bus by the master.

The CM-PDP module is equipped with a DIP switch for activating of the 220 Ω termination burden resistor.

Technical data			
Cable length (m)	Baud rate (kbaud)	1200	9,6
		1200	19,2
		1200	45,45
		1200	93,75
		1000	187,5
		400	500
		200	1500
		100	3000
		100	6000
		100	12000

The values shown in the table are guideline and may be subject to variations in relation to the wiring and cable characteristics.

CANopen/ CM-CAN communication

The CM-CAN communication card with controller area network interface complies with ISO/DIS 11898 transmission standard. The pinout of connector DB9 is based on the "CAN in Automation e.V." specification, which permits the connection of up to 127 nodes in the network. The network node addresses are assigned via software. The 120Ω burden resistor is activated by means of a DIP switch on the module. The current transmission protocol complies with CANopen specifications DS-301 V4.02. As in all transmission processes, the maximum permissible distance between the various bus nodes depends on the cable used and the selected transmission rate.



Internal dipswitch to enable the 120 Ω terminating burden resistor incorporated in the module



Accommodation of CM-CAN module on the frequency inverter

Technical data

Cable length (m)	5000	Baud rate (kBaud)	10
	2500		20
	1000		50
	800		100
	500		125
	250		250
	100		500
	25		1000

The values shown in the table are guideline and may be subject to variations in relation to the wiring and cable characteristics.

System bus / EM-SYS module



Accommodation of EM-SYS module on the frequency inverter

The system bus of ACT inverters is a communication means based on the CANopen protocol that enables rapid exchange of data between the inverters and access, by a system bus master, to the parametric data of all devices connected on the system bus. The system bus nodes (max. 64) are connected by a two-wire line.

The bus termination at the physically first and last node can alternatively be activated via two DIP switches of the EM-SYS module. Active or passive bus termination can be selected.

The system bus is equipped with three PDO (Process Data Object) channels that allow rapid exchanges of process data for each inverter. There are also two SDO (Service Data Object) channels for parameterisation purposes.

Thanks to the three PDO channels with one transmission and one reception channel, all inverter data can be transmitted. Among other advantages, this makes it possible to create master/slave and daisy chain configurations easily, while ensuring very high precision and speed.

Each transmission and reception channel includes 8 bytes that can be freely occupied by objects, thereby offering the maximum flexibility for a very broad range of applications. The selection of transmission objects and reception objects is simplified by the VPlus program, and no additional configuration tools are needed.

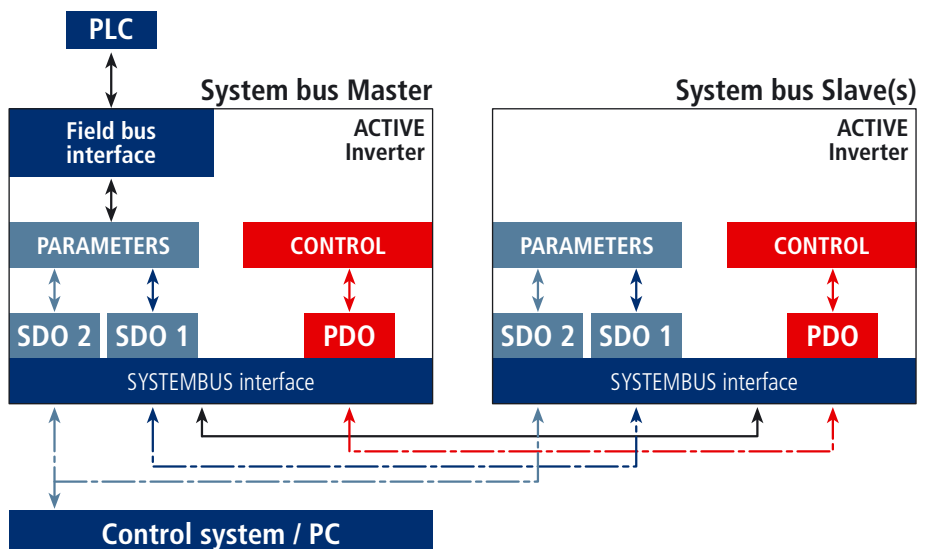

Input-output module / EM-IO-01

The EM-IO-01 expansion modules extends the number of the standard inputs and outputs provided on the ACT inverter for connection of various applications.

Analog inputs and outputs can be available also with bipolar signals and must therefore be configured with inverter parameters.

The supplementary digital inputs provided on the expansion module are electrically equivalent to the standard inputs. The relay changer contact constitutes an alternative for the activation of high power with respect to the relay output available as a standard feature.

The SYSTEMBUS is available on two control terminals and supports easy control of decentralised drive systems.

The module is equipped with a removable terminal board divided into two parts (X410A and X410B) that are physically separated one from the other.

- 3 Digital inputs
- 2 Relay outputs
- 1 Analogue input
- 1 Analogue output
- DC 20 V output
- Systembus



Accommodation of EM-IO-01 module on the frequency inverter

Terminal board layout and functions:

Terminal	Function
X410A.1	DC 20 V power supply output (180 mA)
X410A.2	GND for DC 20 V
X410A.3	EM-S1IND multifunction digital input $V_{max} = DC 30 V(24 V/10 mA)$, PLC compatible
X410A.4	EM-S2IND multifunction digital input $V_{max} = DC 30 V(24 V/10 mA)$, PLC compatible
X410A.5	EM-S3IND multifunction digital input $V_{max} = DC 30 V(24 V/10 mA)$, PLC compatible
X410A.6	EM-S1OUTD multifunction relay output, $U_{max} = DC 24 V, 1 A$ (ohmic)
X410A.7	

Terminal board X410A

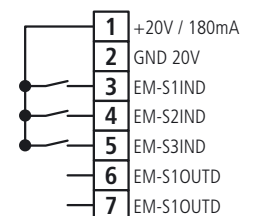

Terminal	Function
X410B.1 X410B.2	EM-S2OUTD multifunction relay output, $U_{max} = DC 24 V, 1 A$ (ohmic)
X410B.3	EM-S1INA DC +/- 10 V and DC +/- 20 mA analog input
X410B.4	EM-S1OUTA DC +/- 10 V multifunction analog output
X410B.5	CAN-Low Systembus
X410B.6	CAN-High Systembus
X410B.7	GND for +/- 10 V signals

Terminal board X410B

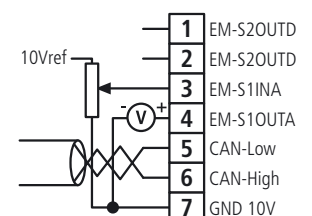

Input-output module / EM-IO-02



Like the previously illustrated EM-IO-01, the EM-IO-02 expansion module extends the standard inputs and outputs featured on ACT frequency inverters. The EM-IO-02 module has a slightly modified layout compared to the -01 version, featuring an input for a PTC thermal probe in place of one of the module relay outputs. The functions of all the other terminals are identical to the version illustrated above.

- 3 Digital inputs
- 1 Relay outputs
- 1 Analog input
- 1 Analog output
- DC 20 V output
- Motor PTC evaluation
- Systembus



Accommodation of EM-IO-02 module on the frequency inverter

Terminal board layout and functions:

Terminal board X410A

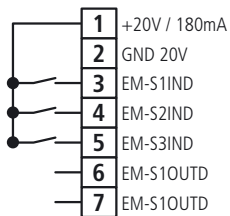

Terminal	Function
X410A.1	DC 20 V power supply output (180 mA)
X410A.2	GND for DC 20 V
X410A.3	EM-S1IND multifunction digital input $V_{max} = DC 30 V(24 V/10 mA)$, PLC compatible
X410A.4	EM-S2IND multifunction digital input $V_{max} = DC 30 V(24 V/10 mA)$, PLC compatible
X410A.5	EM-S3IND multifunction digital input $V_{max} = DC 30 V(24 V/10 mA)$, PLC compatible
X410A.6	EM-S1OUTD multifunction relay output, $U_{max} = DC 24 V, 1 A$ (ohmic)
X410A.7	

Terminal board X410B

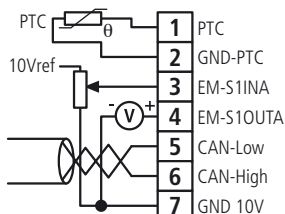

Terminal	Function
X410B.1	Input for motor PTC
X410B.2	GND for motor PTC
X410B.3	EM-S1INA DC +/- 10 V and DC +/- 20 mA analog input
X410B.4	EM-S1OUTA DC +/- 10 V multifunction analog output
X410B.5	CAN-Low Systembus
X410B.6	CAN-High Systembus
X410B.7	GND for +/- 10 V signals

Input-output module / EM-IO-03

The EM-IO-03 expansion module is another variant for the extension of I/O facilities of ACTIVE frequency inverters.

- 2 Digital inputs
- 1 Relay outputs
- 1 Analog input
- 2 Analog output
- DC 20 V output
- Motor PTC evaluation
- Systembus



Accommodation of EM-IO-03 module on the frequency inverter

Terminal board layout and functions:

Terminal	Function
X410A.1	DC 20 V power supply output (180 mA)
X410A.2	GND for DC 20 V
X410A.3	EM-S2OUTA DC +/- 10 V multifunction analog output
X410A.4	EM-S2IND multifunction digital input $V_{max} = DC 30 V(24 V/10 mA)$, PLC compatible
X410A.5	EM-S3IND multifunction digital input $V_{max} = DC 30 V(24 V/10 mA)$, PLC compatible
X410A.6	EM-S1OUTD multifunction relay output, $U_{max} = DC 24 V, 1 A$ (ohmic)
X410A.7	

Terminal	Function
X410B.1	Input for motor PTC
X410B.2	GND for motor PTC
X410B.3	EM-S1INA DC +/- 10 V and DC +/- 20 mA analog input
X410B.4	EM-S1OUTA DC +/- 10 V multifunction analog output
X410B.5	CAN-Low Systembus
X410B.6	CAN-High Systembus
X410B.7	GND for +/- 10 V signals

Terminal board X410A

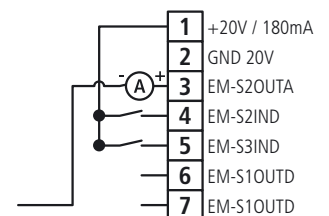

Terminal board X410B

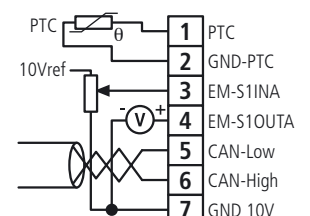

Input-output module / EM-IO-04



The EM-IO-04 expansion module is another variant for the extension of I/O facilities of ACTIVE frequency inverters.

- 2 Digital inputs
- 1 Digital Port (input or output)
- DC 20 V output
- Motor PTC or KTY evaluation
- Systembus



Accommodation of EM-IO-04 module on the frequency inverter

Terminal board layout and functions:

Terminal board X410A

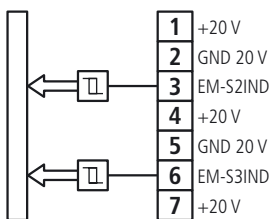

Terminal	Function
X410A.1	DC 20 V power supply output (max. 180 mA)
X410A.2	GND for DC 20 V
X410A.3	EM-S2IND multifunction digital input $V_{max} = DC 30 V(24 V/10 mA)$, PLC compatible
X410A.4	DC 20 V power supply output (max. 180 mA)
X410A.5	GND for DC 20 V
X410A.6	EM-S3IND multifunction digital input $V_{max} = DC 30 V(24 V/10 mA)$, PLC compatible
X410A.7	DC 20 V power supply output (max. 180 mA)

Terminal board X410B

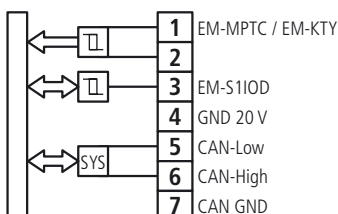

Terminal	Function
X410B.1 X410B.2	Motor PTC thermistor connection EM-MPTC or connection motor temperature sensor EM-KTY
X410B.3	Digital Port EM-S1IOD / Digital input or digital output
X410B.4	GND for DC 20 V
X410B.5	CAN-Low Systembus
X410B.6	CAN-High Systembus
X410B.7	GND for +/- 10 V signals

Speed sensor module / EM-ENC-01

The EM-ENC-01 expansion module extends the number of speed sensor inputs with respect to the standard terminal board of the frequency inverter, and also increases the number of configurable pulse outputs.

This module is able to manage TTL and HTL incremental speed sensors to standard EIA RS422 (line driver) with 5-volt logic. The EM-ENC-01 speed sensor module is equipped with connection terminals for signals A, \bar{A} , B and \bar{B} of the line driver speed sensor and terminals for repetition output of the same signals (speed sensor emulation). This makes it possible to create master-slave configurations between several separate units using the output signals of one unit as the input signals of the next.

The DC +/- 10 V analog input can be used for the inverter frequency reference signal. The same terminal board also provides a DC + 5 V (200 mA) power supply for the line driver speed sensor.

Like the other EM expansion modules, the EM-ENC-01 features a Systembus interface.

- TTL or HTL encoder evaluation (without Zero-Pulse)
- DC +5 V encoder supply
- Analog output
- Frequency repetition output



Accommodation of EM-ENC-01 module on the frequency inverter

Terminal board layout and functions:

Terminal	Function
X410A.1	Channel A speed sensor input
X410A.2	Channel \bar{A} speed sensor input
X410A.3	Channel B speed sensor input
X410A.4	Channel \bar{B} speed sensor input
X410A.5	DC +5 V power supply output (max. 200 mA)
X410A.6	5 V power supply GND
X410A.7	Speed sensor channel A repetition output

Terminal	Function
X410B.1	Channel \bar{A} speed sensor repetition output
X410B.2	Channel B speed sensor repetition output
X410B.3	Channel \bar{B} speed sensor repetition output
X410B.4	EM-S1INA +/- 10 V analog input
X410B.5	CAN-Low Systembus
X410B.6	CAN-High Systembus
X410B.7	GND

Terminal board X410A

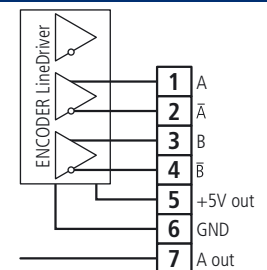

Terminal board X410B

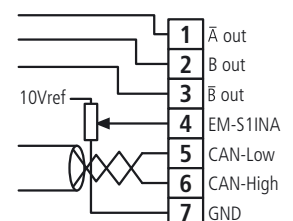

Speed sensor module / EM-ENC-02



Accommodation of EM-ENC-02 module on the frequency inverter

The EM-ENC-02 speed sensor module extends the standard terminal board of the inverter, providing an interface for line driver encoders with relative DC + 5 V power supply.

The same module is equipped also with a DC 0 ... 20 mA and +/- 20 mA analog input and a DC + 20 mA analog output, together with an input for a PTC thermal probe and a digital port configurable as an input or output.

Also this module is equipped with a Systembus port.

- TTL or HTL encoder evaluation (without Zero-Pulse)
- DC +5 V encoder supply
- 1 Digital Port (input or output)
- 1 Analog input
- 1 Analog output
- Motor PTC evaluation
- Systembus

Terminal board layout and functions:

Terminal board X410A

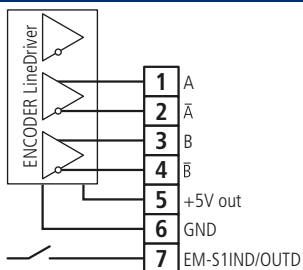

Terminal	Function
X410A.1	Channel A speed sensor input
X410A.2	Channel A-bar speed sensor input
X410A.3	Channel B speed sensor input
X410A.4	Channel B-bar speed sensor input
X410A.5	+ 5 V (200 mA) power supply output
X410A.6	5V power supply GND
X410A.7	EM-S1IND/OUTD digital input/output

Terminal board X410B

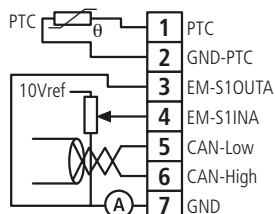

Terminal	Function
X410B.1	Input for motor PTC
X410B.2	GND for motor PTC
X410B.3	EM-S1OUTATA 0 ... 20 mA analog output
X410B.4	EM-S1INA +/- 10 V and +/- 20 mA analog input
X410B.5	CAN-Low Systembus
X410B.6	CAN-High Systembus
X410B.7	GND

Speed sensor module / EM-ENC-03

The EM-ENC-03 extends the standard terminal board of the inverter, providing an interface for line driver speed sensors.

Also this module is equipped with a Systembus port.

Unlike the other EM-ENC-XX modules, the EM-ENC-03 module is not equipped with a power supply output for the speed sensor.

- TTL or HTL encoder evaluation (without Zero-Pulse)
- Systembus



Accommodation of EM-ENC-03 module on the frequency inverter

Terminal board layout and functions:

Terminal	Function
X410A.1	Channel A speed sensor input
X410A.2	Channel \bar{A} speed sensor input
X410A.3	Channel B speed sensor input
X410A.4	Channel \bar{B} speed sensor input
X410A.5	-
X410A.6	GND
X410A.7	-

Terminal	Function
X410B.1	-
X410B.2	-
X410B.3	-
X410B.4	-
X410B.5	CAN-Low Systembus
X410B.6	CAN-High Systembus
X410B.7	GND

Terminal board X410A

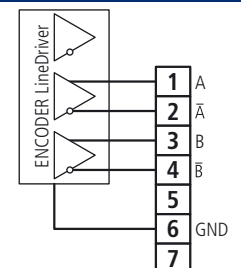

Terminal board X410B

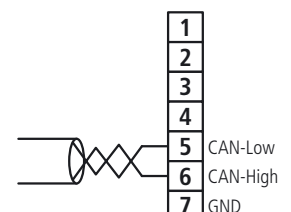

Speed sensor module / EM-ENC-04



Accommodation of EM-ENC-04 module on the frequency inverter

The EM-ENC-04 speed sensor module extends the standard terminal board of the inverter, providing an interface for line driver speed sensors with Z channel. This module is able to manage TTL, HTL, or push-pull incremental speed sensors to standard EIA RS422 (line driver). The EM-ENC-04 speed encoder module is equipped with 6 control terminals for A, \bar{A} , B, \bar{B} direction signals and Z and \bar{Z} zero signals transmitted by the speed sensor. The same module also features a ± 10 V and ± 20 mA analog input and a ± 10 V voltage output in addition to a digital relay output. The module also features two output voltages (+ 5 V and + 24 V) for the speed sensor power supply.

- TTL or HTL encoder evaluation (with Zero-Pulse)
- DC +5 V encoder supply
- DC +20 V encoder and external supply
- 1 Relay output
- 1 Analog input
- 1 Analog output

Terminal board layout and functions:

Terminal board X410A

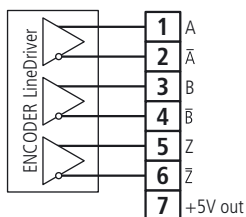

Terminal	Function
X410A.1	Channel A speed sensor input
X410A.2	Channel \bar{A} speed sensor input
X410A.3	Channel B speed sensor input
X410A.4	Channel \bar{B} speed sensor input
X410A.5	Channel Z speed sensor input
X410A.6	Channel \bar{Z} speed sensor input
X410A.7	DC +5 V power supply output (max. 200 mA)

Terminal board X410B

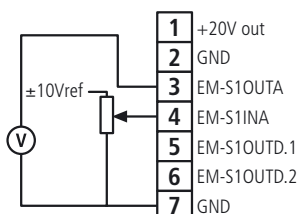

Terminal	Function
X410B.1	DC +20 V power supply output (max. 180 mA)
X410B.2	GND for DC 20 V
X410B.3	EM-S1OUTA DC +/- 10 V multifunction analog output
X410B.4	EM-S1INA DC +/- 10 V or DC +/- 20 mA input
X410B.5	EM-S1OUTD multifunction relay output, $U_{max} = DC 24 V, 1 A$ (ohmic)
X410B.6	
X410B.7	GND for +/- 10 V signals

Speed sensor module / EM-ENC-05

The EM-ENC-05 speed sensor module extends the standard terminal board of the inverter, providing an interface for line driver speed sensors with Z channel. This module is able to manage TTL, HTL, or push-pull incremental speed sensors to standard EIA RS422 (line driver). The EM-ENC05 speed encoder module is equipped with 6 control terminals for A, \bar{A} , B, \bar{B} direction signals and Z and \bar{Z} zero signals transmitted by the speed sensor. The same module also features a ± 10 V and ± 20 mA analog input and a ± 10 V voltage output in addition to a digital relay output. It is also equipped with a SYSTEMBUS communication bus.

- TTL or HTL encoder evaluation (with Zero-Pulse)
- DC +5 V encoder supply
- DC +20 V encoder and external supply
- 1 Analog input
- 1 Analog output



Accommodation of EM-ENC-05 module on the frequency inverter

Terminal board layout and functions:

Terminal	Function
X410A.1	Channel A speed sensor input
X410A.2	Channel \bar{A} speed sensor input
X410A.3	Channel B speed sensor input
X410A.4	Channel \bar{B} speed sensor input
X410A.5	Channel Z speed sensor input
X410A.6	Channel \bar{Z} speed sensor input
X410A.7	DC +5 V power supply output (max. 200 mA)

Terminal board X410A

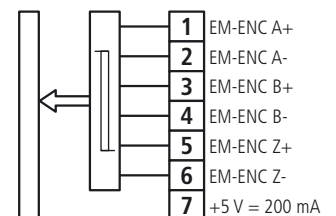

Terminal	Function
X410B.1	DC +20 V power supply output (max. 180 mA)
X410B.2	GND for DC 20 V
X410B.3	EM-S10UTA DC +/- 10 V multifunction analog output
X410B.4	EM-S11INA DC +/- 10 V or DC +/- 20 mA input
X410B.5	CAN-Low Systembus
X410B.6	CAN-High Systembus
X410B.7	GND for +/- 10 V signals

Terminal board X410B

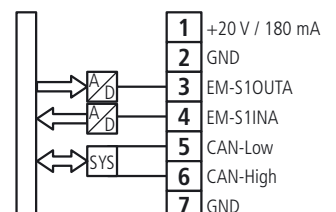

Resolver Module / EM-RES-01



Accommodation of EM-RES-01 module on the frequency inverter

The EM-RES-01 angular position transducer module extends the standard functions of the frequency inverter by providing a supplementary input for a resolver (electromechanical absolute speed sensor).

Speed sensors of this type, referred to also as angular position transducers or angle speed sensors, provide the instantaneous motor shaft position value also when the motor is at a standstill, and its current angular position with respect to a complete revolution.

The 6 terminals of the module EM-RES-01 are provided for connection of the two $\sin\theta$ and $\cos\theta$ track signals generated by the transducer and also carry the resolver power supply voltage.

The module EM-RES-01 also supplies an emulation output of a digital incremental speed sensor through the generation of squarewave signals A, \bar{A} , B, \bar{B} , which can be utilised for spinning shaft synchronisation of any connected slave inverters.

The EM-S11NA multifunction analog input ($\pm 10\text{ V}$ or $\pm 20\text{ mA}$) extends the standard functions of the ACT frequency inverter.

- Resolver evaluation
- Frequency repetition output without Zero-Pulse
- Analog input
- Systembus

Terminal board layout and functions:

Terminal board X410A

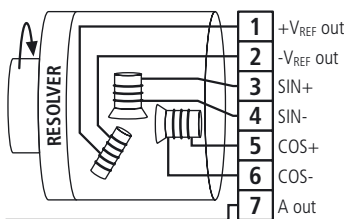

Terminal	Function
X410A.1	(+) ~6 VAC resolver power supply
X410A.2	(-) ($I_{\max} = 60\text{mA}$)
X410A.3	Resolver $\sin\theta$ signal input
X410A.4	
X410A.5	Resolver $\cos\theta$ signal input
X410A.6	
X410A.7	Channel A speed sensor emulation

Terminal board X410B

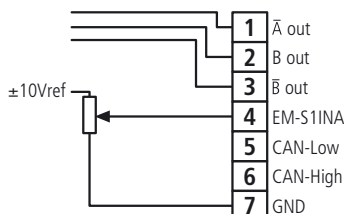

Terminal	Function
X410B.1	Channel \bar{A} speed sensor emulation
X410B.2	Channel B speed sensor emulation
X410B.3	Channel \bar{B} speed sensor emulation
X410B.4	EM-S11NA DC $\pm 10\text{ V}$ or DC $\pm 20\text{ mA}$ input
X410B.5	CAN-Low Systembus
X410B.6	CAN-High Systembus
X410B.7	GND

Resolver Module / EM-RES-02

Also the EM-RES-02 angular position transducer module extends the standard functions of the frequency inverter by providing a supplementary input for a resolver. This module shares all the features of the previously illustrated EM-RES-01 except for the emulation of the encoder zero signal, which in this case is replaced by the Systembus port.

- Resolver evaluation
- Frequency repetition output with Zero-Pulse
- Analog input



Accommodation of EM-RES-02 module on the frequency inverter

Terminal board layout and functions:

Terminal	Function
X410A.1	(+) ~6 VAC resolver power supply
X410A.2	(-) ($I_{max} = 60mA$)
X410A.3	Resolver $sen\theta$ signal input
X410A.4	
X410A.5	Resolver $cos\theta$ signal input
X410A.6	
X410A.7	Channel A speed sensor emulation

Terminal	Function
X410B.1	Channel \bar{A} speed sensor emulation
X410B.2	Channel B speed sensor emulation
X410B.3	Channel \bar{B} speed sensor emulation
X410B.4	EM-S1INA DC +/- 10 V or DC +/- 20 mA input
X410B.5	Channel Z speed sensor emulation
X410B.6	Channel \bar{Z} speed sensor emulation
X410B.7	GND

Terminal board X410A

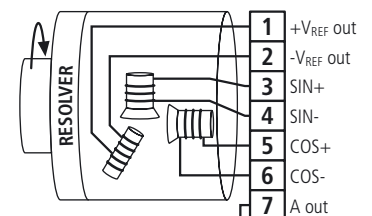

Terminal board X410B

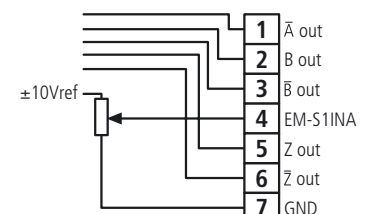

- 110** - Simple Sensorless Control
- 111** - Simple Sensorless Control with PI function
- 115** - Simple Sensorless Control with master / slave control
- 116** - Simple Sensorless Control with synchronisation control
- 160** - Simple Sensorless Control with Brake Control and Load Detection
- 210** - Field-oriented control with speed sensor
- 211** - Field-oriented control with speed sensor and PI function
- 215** - Field-oriented control with speed sensor with master / slave function
- 216** - Field-oriented control with speed sensor with electric shaft
- 230** - Field-oriented control with speed sensor with torque/speed switching
- 260** - Field-oriented control with speed sensor with Brake Control and Load Detection
- 410** - Sensorless Control with extended tuning
- 411** - Sensorless field orientation control with PI regulator
- 415** - Sensorless field orientation control with electronic gearbox and position control
- 430** - Sensorless Control with extended tuning and torque / speed control switching
- 460** - Sensorless Control with extended tuning and with Brake Control and Load Detection
- 510** - Sensorless field orientation control of a synchronous machine
- 515** - Sensorless field orientation control of a synchronous machine with electronic gear and position control
- 516** - Sensorless field orientation control of a synchronous machine with electronic gear and index control
- 530** - Sensorless field orientation control of a synchronous machine with torque/speed switching
- 560** - Sensorless field orientation control of a synchronous machine with electronic gear and position control

By default the ACT frequency inverter is supplied with configuration 110.

Configurations can be changed from the control unit or PC (VPlus) by means of parameter P030.

Configuration 110 is recommended for low dynamic applications or for speed control of several motors in parallel (in the event that the inverter selection criterion is based on the sum of the rated currents of the motors to be driven).

Configuration 111 is recommended for driving turbine machinery (pumps and fans).

Configuration 410 provides high dynamic performance also at low speed without the use of a speed sensor. For enhanced performance the motor data must be entered and the system must be tuned; in addition, the speed controller must be set up for the optimisation of dynamic performance in accordance with the moment of inertia of the load.

This configuration can also be used for simple resolvers by implementing the internal function for positioning from an external reference point (e.g. proximity switch).

Configuration 460 is particularly suitable for elevators and lifting drives in general (cranes, travelling hoists, etc.).

Configuration 210 requires the use of a speed sensor (push-pull or line driver); this configuration allows the most precise load control in terms of speed and torque, including control with nominal torque at zero rpm (standstill with torque).

Configuration 216 can be utilised for synchronous tie applications between several motors with definition of angular phase differences between each axis.

Configuration 510 is the standard synchronous motor operation. This configuration needs a synchronous motor with Resolver and an ACT device with EM-RES.

Configuration 515 adds the functionality of the electronic gear to the configuration 510. Configuration 516 allows synchronous tied applications with an index control.

Configuration 560 adds extended brake control and is suited especially for vertical movements.

Parking brake control (X60 configurations)

Many drives, particularly in the mechanical engineering industry, require a holding brake that maintains the position that has been reached even in the event of power losses. An extended system is available for holding brake control for lifting drives. In addition to holding brake control, this includes also control of the circuit breaker between motor and inverter in certain cases (e.g. elevators).

To compensate for the response time of mechanical components, parameterisation of switching times can be executed with timers. This solution makes it possible to optimise starting and stopping behaviour in the case of suspended loads.

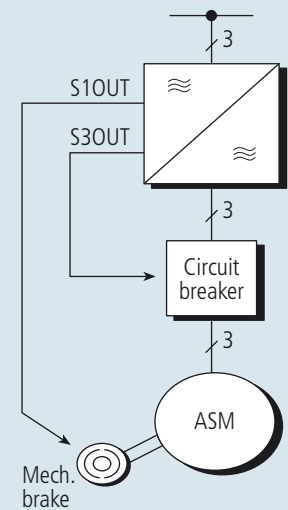
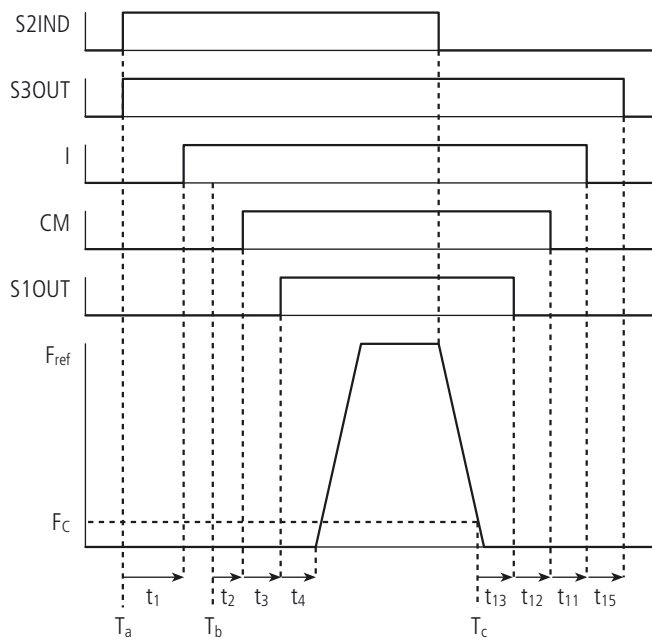

Motor brake (motor chopper) parameter P507

The Motor Chopper function (P507) allows efficient braking of drives with high flywheel loads without requiring external components such as brake units or mains recovery devices.

Positioning (parameters from P458 to P464)

With "Positioning from a reference point" (Parameters P458 to P464), users can position a drive starting from an external signal (e.g. proximity switch). The reference point is acquired on the digital inputs and the target position can be parameterised. "Positioning from a reference point" can be employed independently of the control configuration (with/without speed sensor). Since it is possible to select drive behaviour once the target position has been reached, "Positioning from a reference point" is also suitable for fully automatic drive systems.

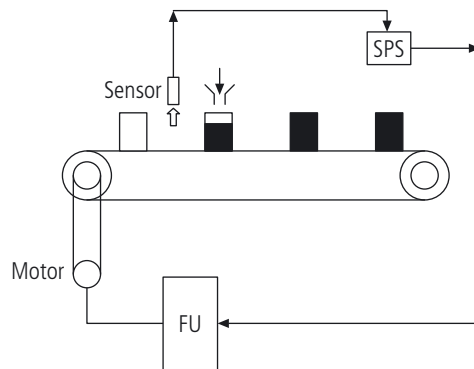

Timer Functions (parameters P790 to P795)

The system is equipped with two timers which are connected, in the standard configuration, to a digital input and a digital output but which can be associated, by means of programming, with the I/Os and several internal functions. Delay times can be programmed in a range from 10 ms up to 650 hours. Multiple operating modes permit the adaptation of the Timer function to meet the requirements of a broad range of applications.

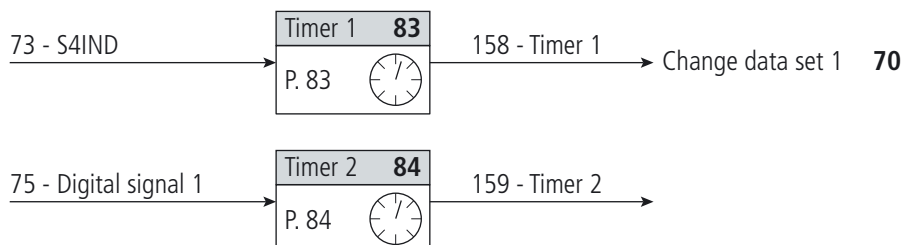

The ACT frequency inverter systembus is an economical and powerful communication system allowing the connection of up to 64 ACT inverters. Taking account of its characteristics, the systembus is based on CAN and is implemented along the lines of CANopen methods. The systembus has two SDO channels and three PDO channels.

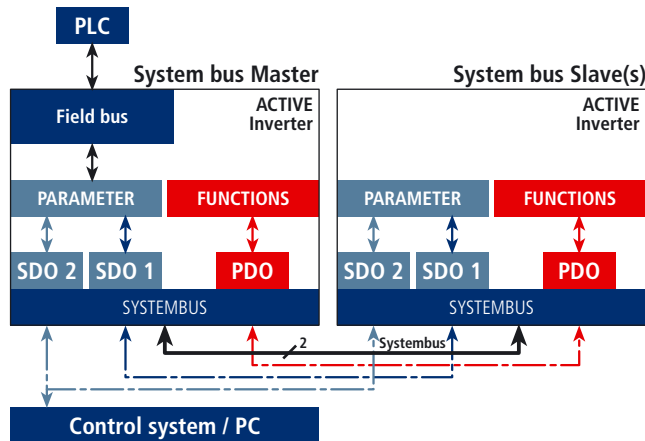

Channel SDO1 allows access to the real parameters and values of all the inverters in the systembus from an external control system (e.g. PLC, NC, etc.). For this reason the master inverter must be interfaced with the field bus. Channel SDO2 is used for connection of a PC display tool for Windows. This display tool allows parameterisation and monitoring of the process on-line.

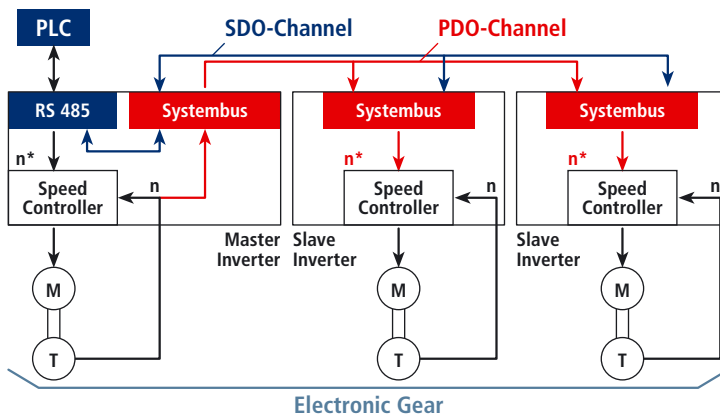

Data can be exchanged between inverters with very high speed and precision by means of the PDO channels. Data exchange can take place between any of the inverters in the systembus.

In the case of a master/slave control, nominal speed is transmitted from the master inverter to the slaves. This strategy makes it possible to obtain an adjustable speed ratio between the master and one or more slaves. In the case that speed sensors are used on the master and on the slaves, it is possible to implement a synchronous tie with angular ratios that can be modified on-line.

Master/slave synchronisation (X16 configurations)

Synchronisation of handling processes (e.g. conveyor belts) is one of the functions available with the standard firmware.

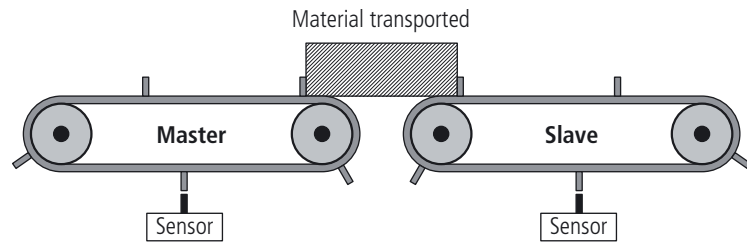

There are several dedicated inputs for synchronisation signals (electronic gear). For master-slave control it is possible to set angular ratios with very high resolution. An offset can be programmed between two conveyor belts. The synchronism regulator can be activated/deactivated by means of a programmable digital input, e.g. for alignment procedures.

For functional control the current deviation between master and slave can be monitored. If a programmable threshold value is exceeded an error signal can be generated by means of a freely configurable digital output.

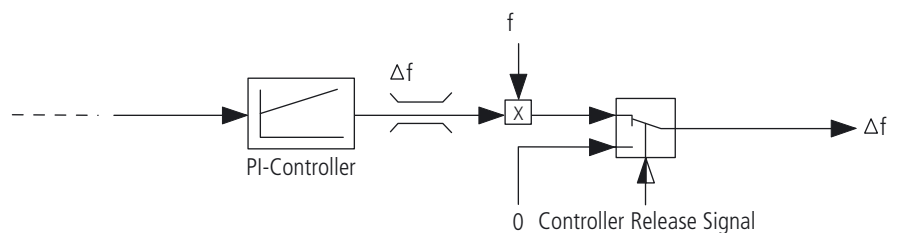
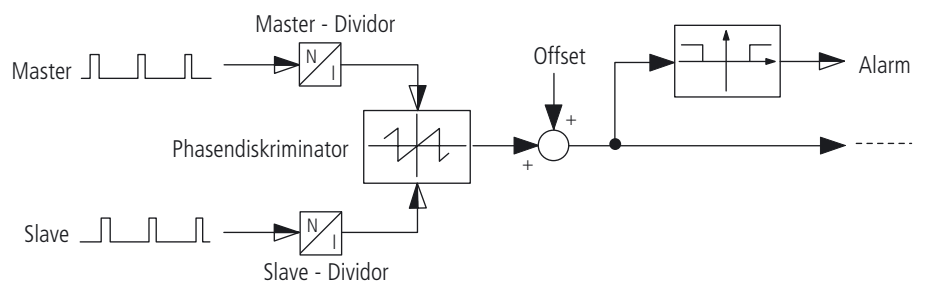

A wide range of mechanical accessories is available for ACT Series frequency converters, to make installation extremely easy in all sorts of application.

In standard mountings the unit can be installed directly on the mounting plate or through-the-wall. A vibration-proof mounting variant and a standard DIN bar mounting variant are also available.

The range of mounting variants also includes an optional support with shielded brackets, so that the right solution for all possible needs can always be found.

Installations are practically identical for all sizes, so the examples shown below can be taken as representative solutions and ideal for all installers seeking a mechanically simple, compact installation solution.

Types of assembly kits

The drive is supplied complete with a standard installation kit for fixing to an electrical cabinet mounting panel.

3 different optional installation kits are available on request.

MPSV

Thru-type assembly for higher protection classes or enhanced cooling characteristics

MNVIB

Anti-vibration mounting for installations on machines that generate significant vibrational stress

MDIN

DIN rail assembly for fast and modular installation / coupling

Size 1

Standard assembly

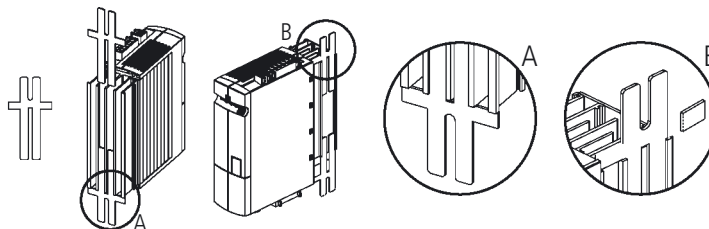

Inverter BONFIGLIOLI

Assembly kit

Description

ACT 201-05 ... ACT 201-09
ACT 401-05 ... ACT 401-11

MPSV1

Thru-type assembly

MNVIB1

Antivibration assembly

MDIN1

DIN rail assembly

MPSV1

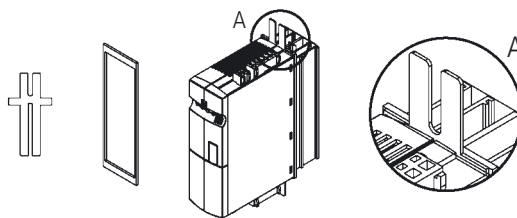

MNVIB1

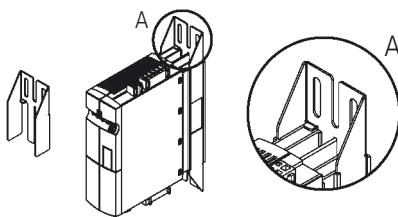

MDIN1

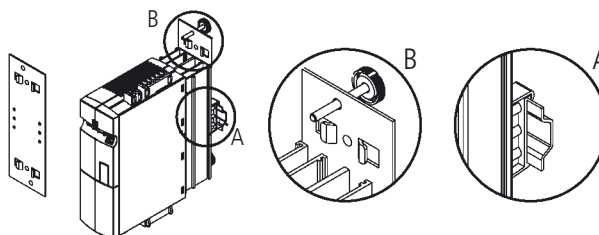

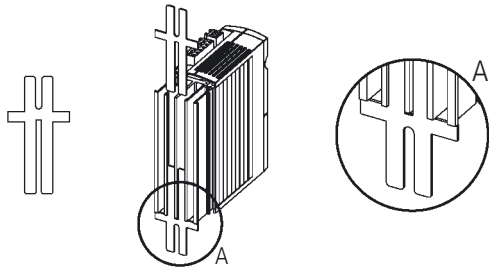

Standard assembly

Size 2

Inverter BONFIGLIOLI	Assembly kit	Description
ACT 201-11 ... ACT 201-15 ACT 401-12 ... ACT 401-18	MPSV2	Thru-type assembly
	MNVIB2	Antivibration assembly
	MDIN2	DIN rail assembly

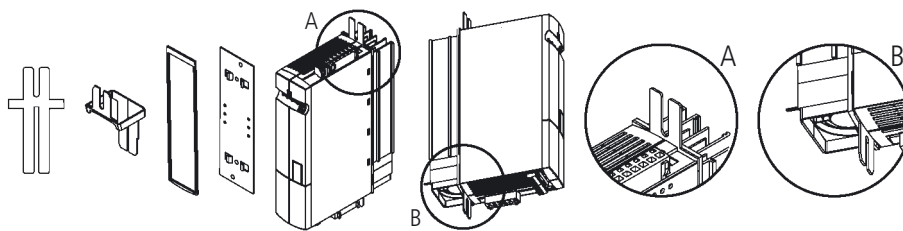

MPSV2

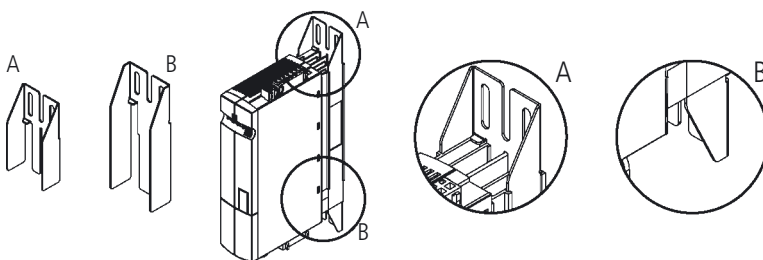

MNVIB2

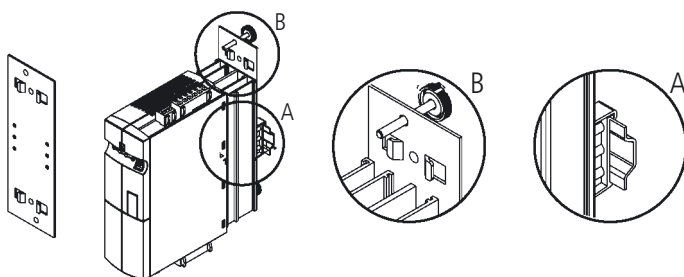

MDIN2

Size 3

Standard assembly

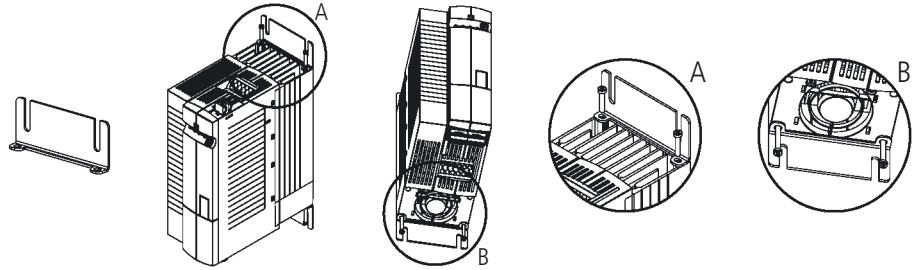

Inverter BONFIGLIOLI

ACT 201-18 ... ACT 201-19
ACT 401-19 ... ACT 401-22

Assembly kit

Description

MPSV3

Thru-type assembly

MNVIB3

Antivibration assembly

MPSV3

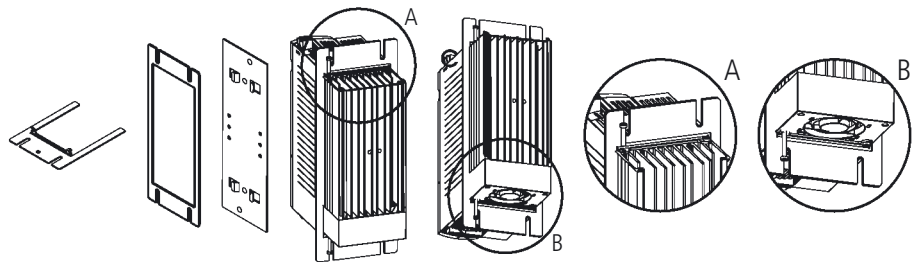

MNVIB3

Accessories available subject to the Drive Service
Centre's analysis and approval

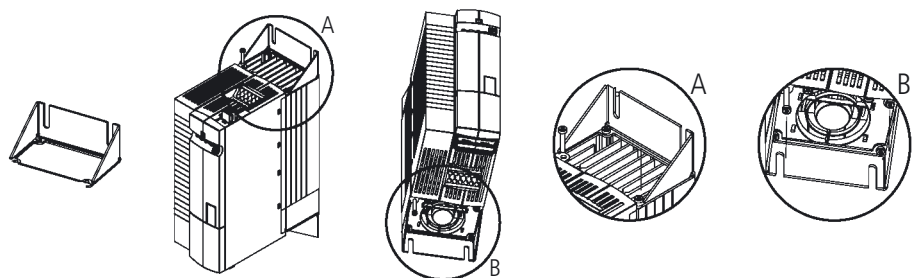

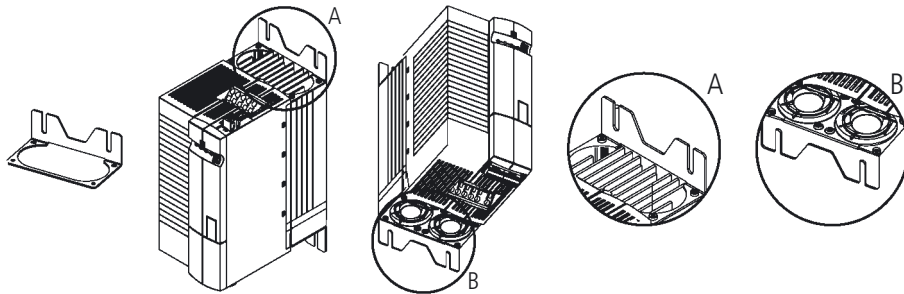

Standard assembly

Size 4

Inverter BONFIGLIOLI	Assembly kit	Description
ACT 201-21 ... ACT 201-22	MPSV4	Thru-type assembly
ACT 401-23 ... ACT 401-25	MNVIB4	Antivibration assembly

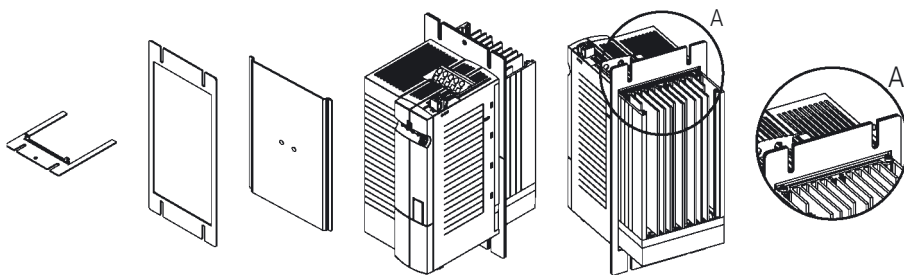

MPSV4

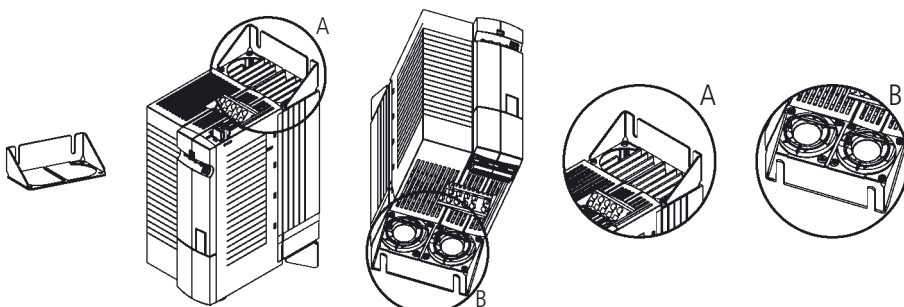

MNVIB4

Accessories available subject to the Drive Service Centre's analysis and approval

Size 5

Standard assembly

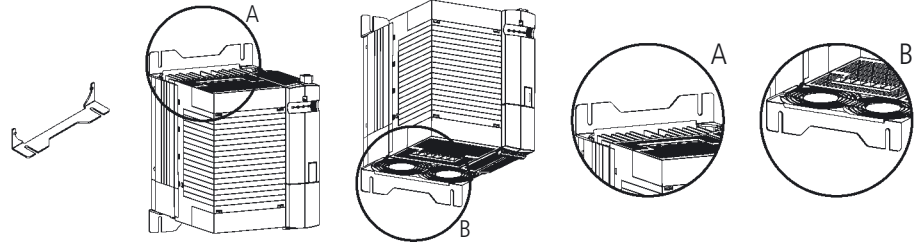

Inverter BONFIGLIOLI

Assembly kit

Description

ACT 401-27 ... ACT 401-31

MPSV5

Thru-type assembly

MNVIB5

Antivibration assembly

MPSV5

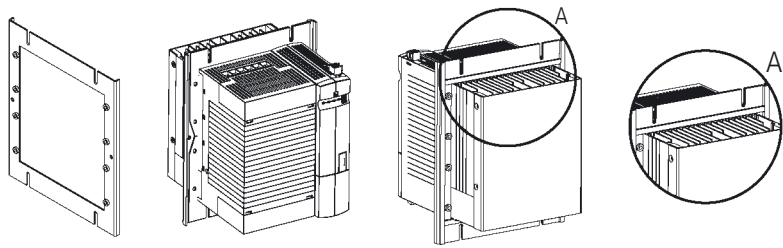

MNVIB5

Accessories available subject to the Drive Service Centre's analysis and approval

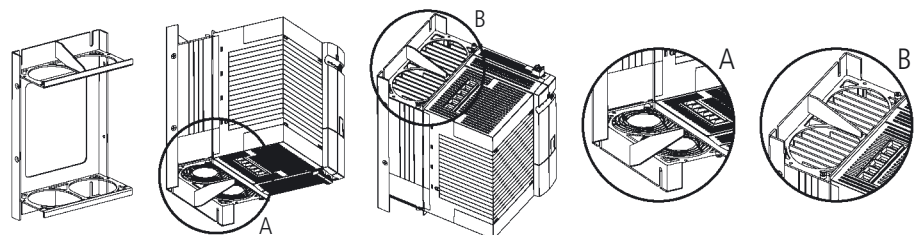

Standard assembly

Size 6

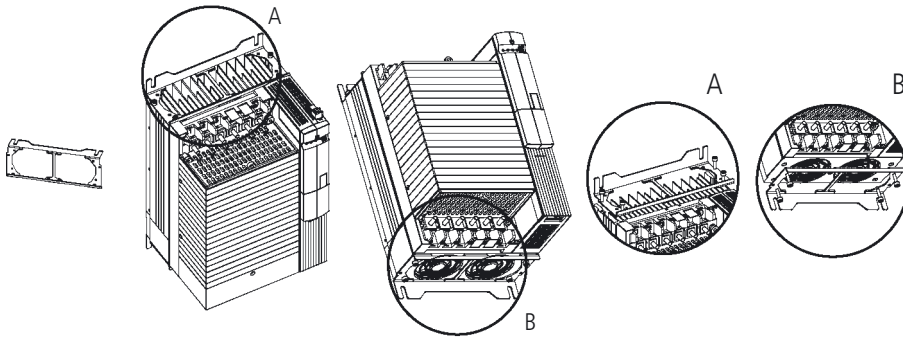

Inverter BONFIGLIOLI	Assembly kit	Description
ACT 401-33 ... ACT 401-39	MPSV6	Thru-type assembly
	MNVIB6	Antivibration assembly

MPSV6

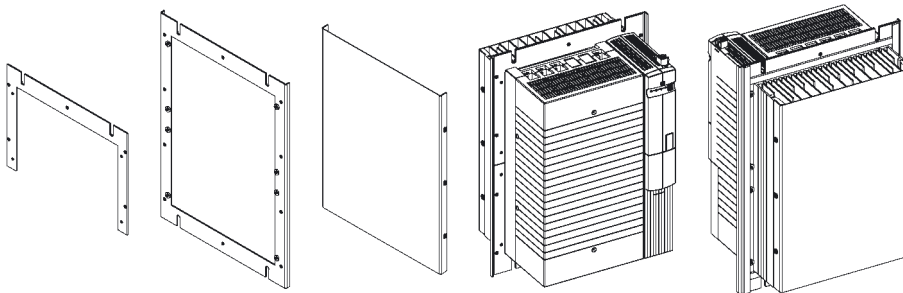

MNVIB6

Accessories available subject to the Drive Service
Centre's analysis and approval

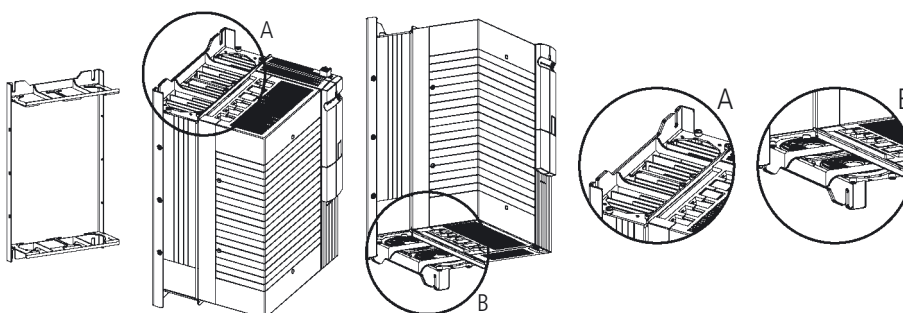

Size 7

Standard assembly

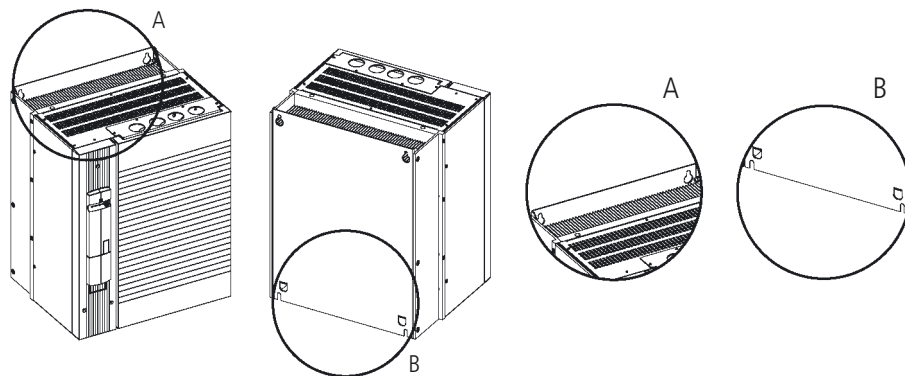

Inverter BONFIGLIOLI

ACT 401-43...ACT 401-49

Assembly kit

MPSV7

Description

Thru-type assembly

MPSV7

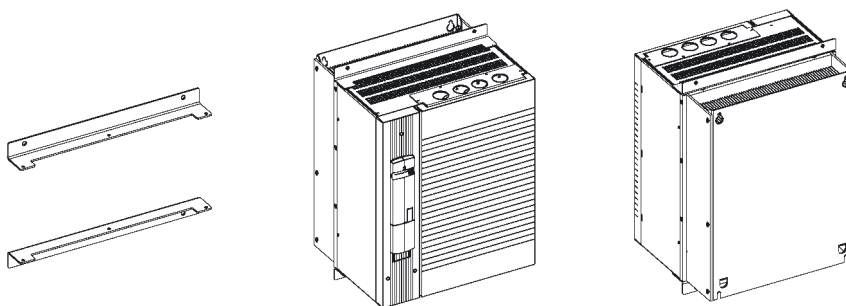

Why an input filter?

An Input Filter is a filtration device to be installed up-line from the frequency inverter and down-line from the power feeding contactor.

The AC/DC rectifier at the inverter input generates harmonic disturbance on the absorbed current and returns disturbance generated by switching components towards the mains. This causes voltage distortions on the mains resulting in electromagnetic interference phenomena.

This harmonic distortion is reduced by means of line chokes, while disturbance is countered with EMI filters (attenuation of EMI voltages) such as those described below.

Note: The use of input filters reduces the inverter input voltage. If required, these filters should be installed up-line from the inverter in the following order:

1. Mains supply
2. Line choke
3. EMI filter
4. Inverter

Line choke

- Line chokes are not strictly necessary: their use depends on the system engineer's need to reduce harmonic distortion in the short circuit point, and the need to reinforce the action of the EMI filter. A line choke is normally used if the mains short circuit power is lower than 1%.
- A line choke is recommended for the ACT201 and ACT401 frequency inverter series in the presence of high continuous input current required by the application, in order to increase the lifetime of the electrolytic capacitors.
- A line choke is always required in single and two-phase operation of the ACT201 frequency inverters.

EMI filter

- An EMI filter can be used in order to achieve Class "A" (groups 1, 2) or Class "B" interference suppression
- The EMI filter is available in a low leakage current version for special applications.
- The EMI - filter is part of the standard outfit in sizes of up to 4.0 kW and it is supplied as an optional for higher sizes in an internal (up to 7.5 kW) or external (above 7.5 kW) version.

Note: Connection to public power networks without further measures must be considered in relation to the provisions of standard EN 61000-3-2. Inverters $\leq 9,2$ kW with integral EMI filters meet the emission thresholds defined by the standard EN 61800-3 with a motor cable length of up to 10 m without requiring any additional measures. Higher requirements related to the need of the specific application in which the frequency inverter is installed can be fulfilled by fitting optional components. Line chokes and EMI filters are available as optional equipment for the inverter series described in this manual.

Input filter

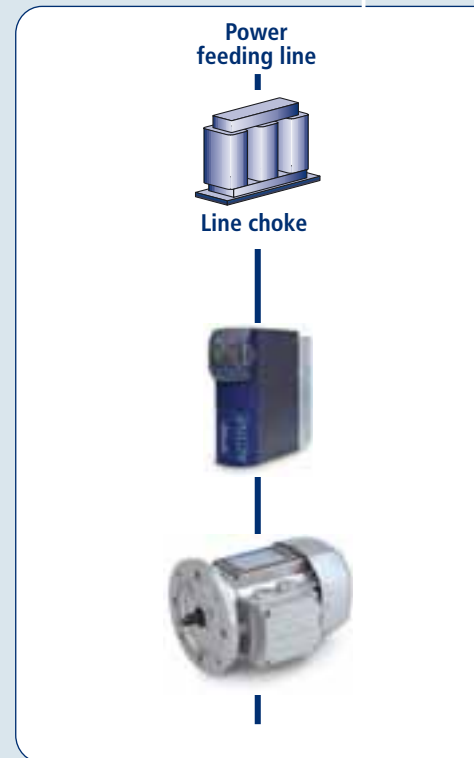

Input filter

ACTIVE inverter - Line choke / EMI filter combination

	Mains Cable Length	Compliance with Class A Group 2		Compliance with Class A Group 1		Compliance with Class B	
		< 10 m	< max*	< 10 m	< max*	< 10 m	< max*
ACT 1 (Standard internal filter)	Standard	Standard	external choke	external choke	external filter	external choke	external filter
ACT 2 (Standard internal filter)	Standard	Standard	external choke	external choke	external filter	external choke	external filter
ACT 3	internal filter or external choke	internal filter or external choke	internal filter + external choke	internal filter + external choke	internal filter + external choke	external filter	external filter
ACT 4	external choke	external filter	external filter	external filter	external filter	external filter + external choke	external filter + external choke
ACT 5	external choke	external choke	external filter	external filter	external filter	external filter + external choke	external filter + external choke
ACT 6	external choke	external choke	external filter	external filter	external filter	external filter	external filter
ACT 7	external choke	external choke	external filter	external filter	—	—	—

* See the operation manual

Line choke



The simplest way of reducing high harmonic components and hence reactive power is connecting a choke in series on the mains side of the inverter. Depending on the system, reactive power consumption can be reduced by approximately 20% of the figure without line choke.

The line choke increases inductance towards the mains. Mains feed line choke can be regarded as sufficient if short-circuit power is from 20 to 40 times higher than the inverter nominal output.

The inverter is suitable for connection to public or industrial mains supplies in compliance with technical data. If the supply mains transformer output is ≤ 500 kVA, the optional mains choke is needed only if specified in the inverter technical data. The other inverters are suitable for the connection to the mains without a mains choke with relative impedance $\geq 1\%$. If it is desired to connect more than one inverter, use the sum of the nominal outputs as a basis.

Since experience has shown that the nominal short circuit power on the inverter connection point is often unknown, BONFIGLIOLI recommends the use of mains chokes with 4% voltage drop.

The relative short circuit voltage equivalent to a 4% voltage drop represents the percentage of the nominal voltage at which a current equal to rated current flows in the case of a short circuit.

The European reference standard for harmonics is EN 60 555, while in the US and Canada systems must comply with standard IEEE 519 and various generic national regulations.

Technical data

Nominal voltages

230V +/- 10%

400V +/- 10%

Frequencies

50/60 Hz

uk (a IN / 50 Hz) 4%

Insulating material class

T40/F

Ambient temperature

40°C maximum

Protection class

IP00 / VBG4

Connection type

Contact-protected terminals

Note: The line choke must be installed between the mains connection point and the EMI filter. Both the line choke and inverter should be installed on a common metal baseplate and each should be connected to the metal mounting plate and earthed by means of a large contact area copper braid.

Line choke

Dimensions

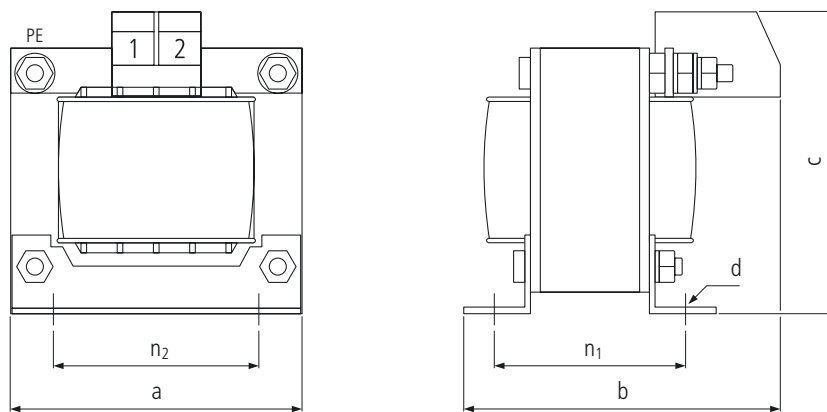

Technical data

BONFIGLIOLI frequency inverter – Line choke combination, **1x230V~**

BONFIGLIOLI Inverter	BONFIGLIOLI Choke	Nominal current	Power dissipation
		[A]	[W]
ACT 201-05	LCVS006	6	8.0
ACT 201-07	LCVS008	8	8.0
ACT 201-09	LCVS010	10	10.0
ACT 201-11	LCVS015	15	12.0
ACT 201-13	LCVS018	18	15.0

Technical assembly data

BONFIGLIOLI Choke	Dimensions			Assembly			Weight	Connection terminal		
	a	b	c	n ₂	n ₁	d		[mm]	[Nm]	PE
	[mm]	[mm]	[mm]	[mm]	[mm]	[mm]	[mm]	[kg]	[mm]	[Nm]
LCVS006	60	62	75	44	38	3.6	0.5	0.75-2.5	1.0-1.2	2.5 mm ²
LCVS008	60	67	75	44	43	3.6	0.6	0.75-2.5	1.0-1.2	2.5 mm ²
LCVS010	66	80	70	50	51	4.8	0.8	0.75-2.5	1.0-1.2	M4
LCVS015	78	78	80	56	49	4.8	1.1	0.75-4.0	1.5-1.8	M4
LCVS018	85	85	95	64	50	4.8	1.8	0.75-4.0	1.5-1.8	M4

Line choke

Dimensions

LCVT004 ... LCVT025

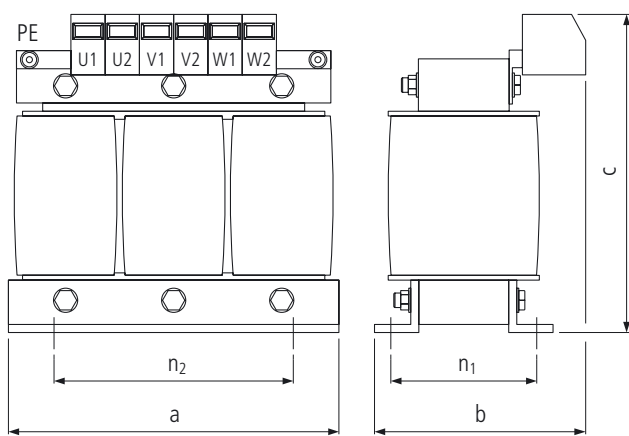

LCVT034 ... LCVT250

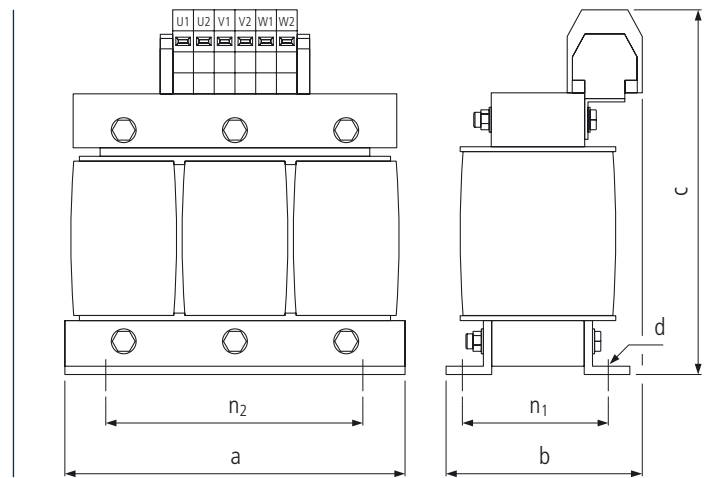

BONFIGLIOLI frequency inverter – Line choke combination, 3x230V~

Technical data

BONFIGLIOLI Inverter	BONFIGLIOLI Choke	Nominal current	Choke	Power dissipation
		[A]	[mH]	[W]
ACT 201-05	LCVT004	4	7,32	20
ACT 201-07	LCVT004	4	7,32	20
ACT 201-09	LCVT006	6	4,88	25
ACT 201-11	LCVT008	8	3,66	30
ACT 201-13	LCVT010	10	2,93	30
ACT 201-15	LCVT015	15	1,95	45
ACT 201-18	LCVT018	18	1,63	70
ACT 201-19	LCVT025	25	1,17	70
ACT 201-21 ACT 201-22	LCVT034	34	0,86	85

Line choke

Technical data

BONFIGLIOLI frequency inverter – Line choke combination, **3x400V~**

BONFIGLIOLI Inverter	BONFIGLIOLI Choke	Nominal current [A]	Choke [mH]	Power dissipation [W]
ACT 401-05	LCVT004	4	7,32	20
ACT 401-07	LCVT004	4	7,32	20
ACT 401-09	LCVT004	4	7,32	20
ACT 401-11	LCVT004	4	7,32	20
ACT 401-12	LCVT004	4	7,32	20
ACT 401-13	LCVT006	6	4,88	25
ACT 401-15	LCVT008	8	3,66	30
ACT 401-18	LCVT010	10	2,93	30
ACT 401-19	LCVT015	15	1,95	45
ACT 401-21	LCVT018	18	1,63	70
ACT 401-22	LCVT025	25	1,17	70
ACT 401-23	LCVT025	25	0,86	85
ACT 401-25	LCVT034	34	0,86	85
ACT 401-27	LCVT050	50	0,59	100
ACT 401-29	LCVT060	60	0,49	100
ACT 401-31	LCVT060	60	0,49	100
ACT 401-33	LCVT075	75	0,37	110
ACT 401-35	LCVT090	90	0,33	120
ACT 401-37	LCVT115	115	0,25	140
ACT 401-39	LCVT135	135	0,22	180
ACT 401-43	LCVT160	160	0,18	180
ACT 401-45	LCVT180	180	0,16	185
ACT 401-47	LCVT210	210	0,14	200
ACT 401-49	LCVT250	250	0,12	210

Technical assembly data

BONFIGLIOLI Choke	Dimensions			Assembly			Weight [kg]	Connection terminal		
	a [mm]	b [mm]	c [mm]	n ₂ [mm]	n ₁ [mm]	d [mm]		[mm]	[Nm]	PE
LCVT004	80	65	95	55	37	4	0,8	0,75-2,5	1,0-1,2	4 mm ²
LCVT006	100	75	115	60	39	4	1,0	0,75-2,5	1,0-1,2	4 mm ²
LCVT008	100	75	115	60	48	4	1,5	0,75-2,5	1,0-1,2	4 mm ²
LCVT010	100	75	115	60	48	4	1,5	0,75-2,5	1,0-1,2	4 mm ²
LCVT015	125	85	135	100	55	5	3,0	0,75-4,0	1,5-1,8	4 mm ²
LCVT018	155	90	135	130	57	8	4,0	0,75-4,0	1,5-1,8	4 mm ²
LCVT025	155	100	160	130	57	8	4,0	0,75-10	4,0-4,5	4 mm ²
LCVT034	155	100	190	130	57	8	4,5	2,5-16	2,0-4,0	M5
LCVT050	155	115	190	130	72	8	4,5	2,5-16	2,0-4,0	M5
LCVT060	190	110	220	170	58	8	9,0	2,5-35	2,5-5,0	M5
LCVT075	190	120	250	170	68	8	12	25-50	3,0-6,0	M6
LCVT090	190	130	250	170	78	8	12	25-50	3,0-6,0	M6
LCVT115	210	140	270	180	82	8	14	25-50	3,0-6,0	M6
LCVT135	240	160	300	190	100	11	20	16-70	6,0-7,0	M8
LCVT160	240	160	310	190	100	11	20	50-95	6,0-12,0	M8
LCVT180	240	175	320	190	106	11	22	50-95	6,0-12,0	M8
LCVT210	240	200	335	190	121	11	26	95-150	10,0-20,0	M8
LCVT250	240	210	350	190	126	11	28	95-150	10,0-20,0	M8

EMI filters

Because of their intrinsic characteristics, all frequency inverters often generate unwanted high frequency voltages generally referred to as "interference". Mains filters are installed to reduce this interference.

Within the European Union reference standard EN 61800-3 defines the maximum thresholds for electromagnetic interference for different classes of equipment.

Active Series frequency converters up to size 9.2 kW can be ordered with a built-in EMI filter conforming to the requirements of the standard for "class A – group 2" environments.

Two series of external interference filters are available for larger size Active frequency inverters and for installations where conformity to the stricter requirements of class B is necessary. The two series differ both in construction and power range.

The first set of filters are "backplate filters". They are available in sizes 7 to 40 A (suitable for Active frequency inverters up to size 4), and allow the frequency inverter to be installed on board the filter itself.

The second series of filters are "book filters". They cover all other Active sizes up to 130 A and are designed for installation on the same mounting panel alongside the drive.

Mains filters with very low dispersion currents are available upon request for specific applications.

Basic circuit diagram

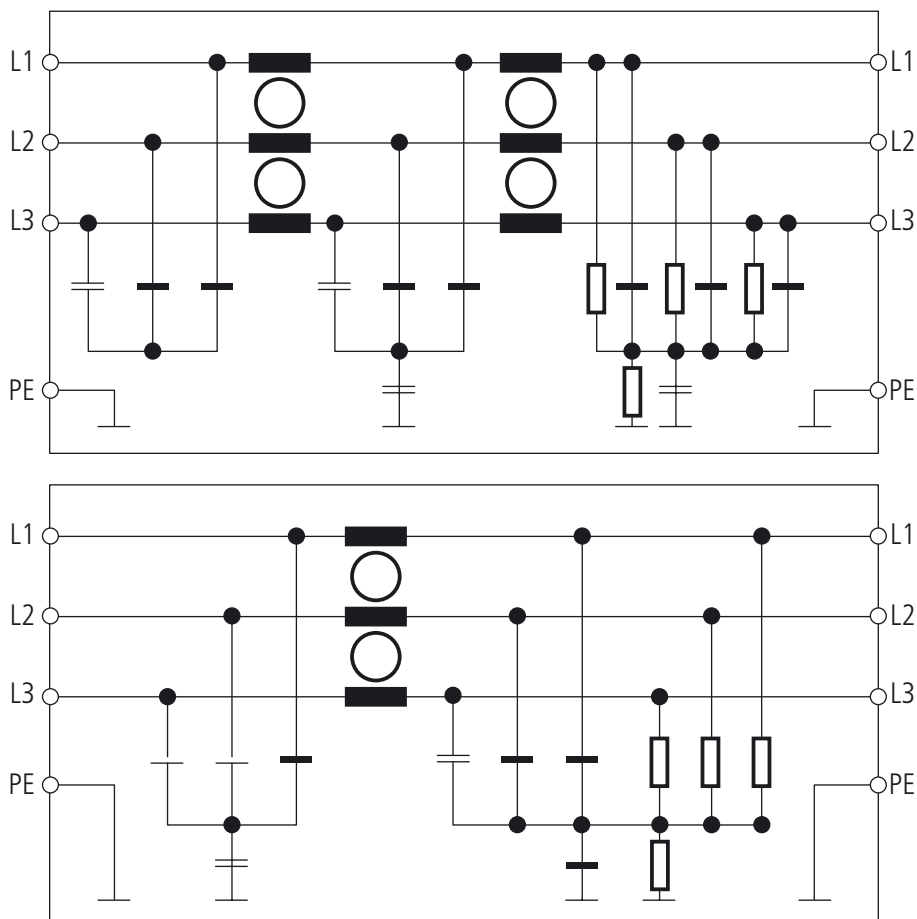

Backplate EMI filters



Technical data

Mains voltage

3 x 480V~ maximum +10%

Nominal current

8A ... 40A

Frequency

50/60 Hz

Operating and storage temperature

-25 °C ... +100 °C (climate class acc. to CEI 25/100/21)

Ambient temperature

+40°C maximum

Protection class

IP00

Connection type

Contact-protected terminals

Strand connection on load side (only up to ACT 401-18)

Metal fasteners are included in the supply

Note: These mains filters are installed between the line choke and the frequency inverters. The frequency inverters installed on the EMI filter must be connected to the metal baseplate with a short, large section earth connection.
Overload capacity is 1.5 times rated current for 1 minute, every 30 minutes.

BONFIGLIOLI Inverter		BONFIGLIOLI EMI filter	Rated current [A]	Leakage current [mA]	Power dissipation [W]
Size	Type				
1	ACT 201-05	FTV007B	8	5	10
	ACT 201-07				
	ACT 201-09				
	ACT 401-05				
	ACT 401-07				
	ACT 401-09				
2	ACT 401-11	FTV018B	18	1,2	10
	ACT 201-11				
	ACT 401-12				
	ACT 401-13				
3	ACT 401-15	FTV040B	40	1,2	10
	ACT 401-18				
	ACT 401-19				
4	ACT 401-21	FTV040B	40	1,2	10
	ACT 401-23				
	ACT 401-25				

Technical specifications

Mains voltage

3 x 480 VAC

Rated current

7 A ... 130 A

Frequency

up to 60 Hz

Operating and storage temperature

-25 °C ... +80 °C (climate class acc. to CEI 25/80/21)

Type of protection

IP20

Maximum length of motor cables:

ACT 401-05 to ACT 401-15: 25 m class B

ACT 401-18 to ACT 401-25: 50 m class B

ACT 401-27 to ACT 401-39: 10 m class B, 100 m class A group 1

ACT 401-43 to ACT 401-49: 10 m class B, 100 m class A group 1

Book type EMI filters



BONFIGLIOLI Inverter		BONFIGLIOLI EMI filter	Rated current	Leakage current	Power dissipation
Size	Type		[A]	[mA]	[W]
1	ACT 201-05	FTV007A	7	33	3,8
	ACT 201-07				
	ACT 201-09				
	ACT 401-05				
	ACT 401-07				
	ACT 401-09				
2	ACT 401-11	FTV016A	16	33	6,1
	ACT 201-11				
	ACT 401-12				
	ACT 401-13				
3	ACT 401-15	FTV030A	30	33	11,8
	ACT 201-13				
	ACT 201-15				
	ACT 401-18				
	ACT 401-19				
4	ACT 401-21	FTV055A	55	33	25,9
	ACT 201-18				
	ACT 201-19				
	ACT 401-22				
5	ACT 201-21	FTV075A	75	33	32,2
	ACT 401-23				
	ACT 401-25				
6	ACT 201-22	FTV100A	100	33	34,5
	ACT 401-27				
	ACT 401-29				
	ACT 401-31				
	ACT 401-33	FTV130A	130	33	43,1
	ACT 401-35				
	ACT 401-37				
	ACT 401-39				
	ACT 401-43	FTV150	150	13	88
	ACT 401-45	FTV180	180		150
	ACT 401-47	FTV210	210		180
	ACT 401-49	FTV250	250		

Note: Overload capacity is 4 times rated current at switch-on; 1.5 times rated current for 1 minute, once per hour.

Braking Resistors



When an electric motor controlled by a frequency inverter is braked, it enters regenerative mode and actually returns power to the inverter. Voltage in the drive's intermediate circuit soon rises as a result. Beyond a certain point excess energy must be yielded to an external braking system. Braking resistors are designed to absorb excess energy and convert it into heat that can then be dissipated. The use of braking resistors permits motors and frequency inverters to be used in work cycles characterised by fierce or extended periods of braking, or by frequent braking.

Bonfiglioli Vectron offers a wide range of safe and compact external braking resistors with protection ratings from IP20 to IP55.

BR series resistors are designed for mounting in a control panel and are also equipped with built-in thermal protection.

Outline of connection

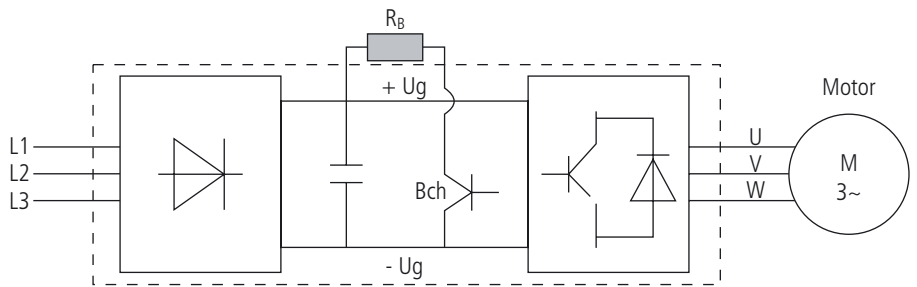

R_B = external braking resistor
Bch = brake chopper integrated in standard ACTIVE inverter

Connection terminals

The Rb1 and Rb2 braking resistor terminals on Active frequency inverters are located on the X2 power output terminal strip. Access to these terminals on size 1 and 2 units is made even easier by the use of disconnectable power terminal strips. Refer to the manual provided with your frequency inverter for further details on materials and connection methods.



**Frequency converter
(from 0.55 to 4.0 kW)**

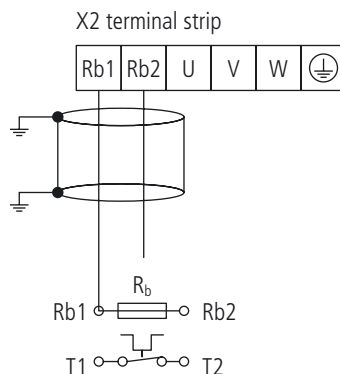

**Frequency converter
(from 5.5 to 65 kW)**

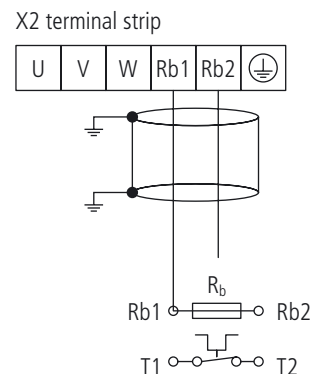

Braking Resistors

Active drive combination chart

These charts show recommended combinations for each model in the Active range, and specify the corresponding duty cycles on the basis of rated drive power. Contact your nearest Bonfiglioli Drive Centre for particularly heavy-duty braking applications or if you need to customise a product.

ACTIVE Series	kW	Bonfiglioli braking resistor	Resistance Ohm	Continuous rated power	Duty cycle at the drive's rated power
ACT 201-05	0,55	BR 160/100	100	160	29%
ACT 201-07	0,75	BR 160/100	100	160	21%
ACT 201-09	1,1	BR 160/100	100	160	15%
ACT 201-11	1,5	BR 432/37	37	432	29%
ACT 201-12	2,2	BR 432/37	37	432	20%
ACT 201-15	3	BR 432/37	37	432	14%
ACT 201-18	4	BR 667/24	24	667	17%
ACT 201-19	5,5	BR 667/24	24	667	12%
ACT 201-21	7,5	BR 1333/12	12	1333	18%
ACT 201-22	9,2	BR 1333/12	12	1333	14%
ACT 401-05	0,55	BR 213/300	300	213	39%
ACT 401-07	0,75	BR 213/300	300	213	28%
ACT 401-09	1,1	BR 213/300	300	213	19%
ACT 401-11	1,5	BR 213/300	300	213	14%
ACT 401-12	1,85	BR 471/136	136	471	25%
ACT 401-13	2,2	BR 471/136	136	471	21%
ACT 401-15	3	BR 471/136	136	471	16%
ACT 401-18	4	BR 696/92	92	696	17%
ACT 401-19	5,5	BR 1330/48	48	1330	24%
ACT 401-21	7,5	BR 1330/48	48	1330	18%
ACT 401-22	9,2	BR 1330/48	48	1330	14%
ACT 401-23	11	BR 2000/32	32	2000	18%
ACT 401-25	15	BR 2000/32	32	2000	13%
ACT 401-27	18,5	BR 4000/16	16	4000	22%
ACT 401-29	22	BR 4000/16	16	4000	18%
ACT 401-31	30	BR 4000/16	16	4000	13%
ACT 401-33	37	BR 8000/7	7,5	8000	22%
ACT 401-35	45	BR 8000/7	7,5	8000	18%
ACT 401-37	55	BR 8000/7	7,5	8000	15%
ACT 401-39	65	BR 8000/7	7,5	8000	12%
ACT 401-43	75	BR8000/7	7,5	8000	11%
ACT 401-45	90	2xBR8000/7	3,75	16000	18%
ACT 401-47	110	2xBR8000/7	3,75	16000	15%
ACT 401-49	132	2xBR8000/7	3,75	16000	12%

Note:

For further information refer to the Bonfiglioli braking resistor catalogue.





Bonfiglioli is a Partner Worldwide for Power Transmission and Motion Control



The ever-growing export share has led Bonfiglioli into the most far away Countries. With expansion plans entailing a further growth of the sales network Bonfiglioli aims at improving both the competitiveness of its products and the effectiveness of the Customer service. In every market place Bonfiglioli is committed to improve the Customer satisfaction by offering state-of-the-art technology and shorter deliveries. Nowadays branch companies and BEST Partners bearing the Bonfiglioli name are operating in seventeen Countries outside Italy, with sales and service in the other countries managed by appointed dealers. The domestic network is made up of 30 sales office and representatives and 100 dealers operating with their own warehouse and supporting Customers locally. Throughout the World Bonfiglioli's reputed know-how and Service guarantee effective and timely assistance.

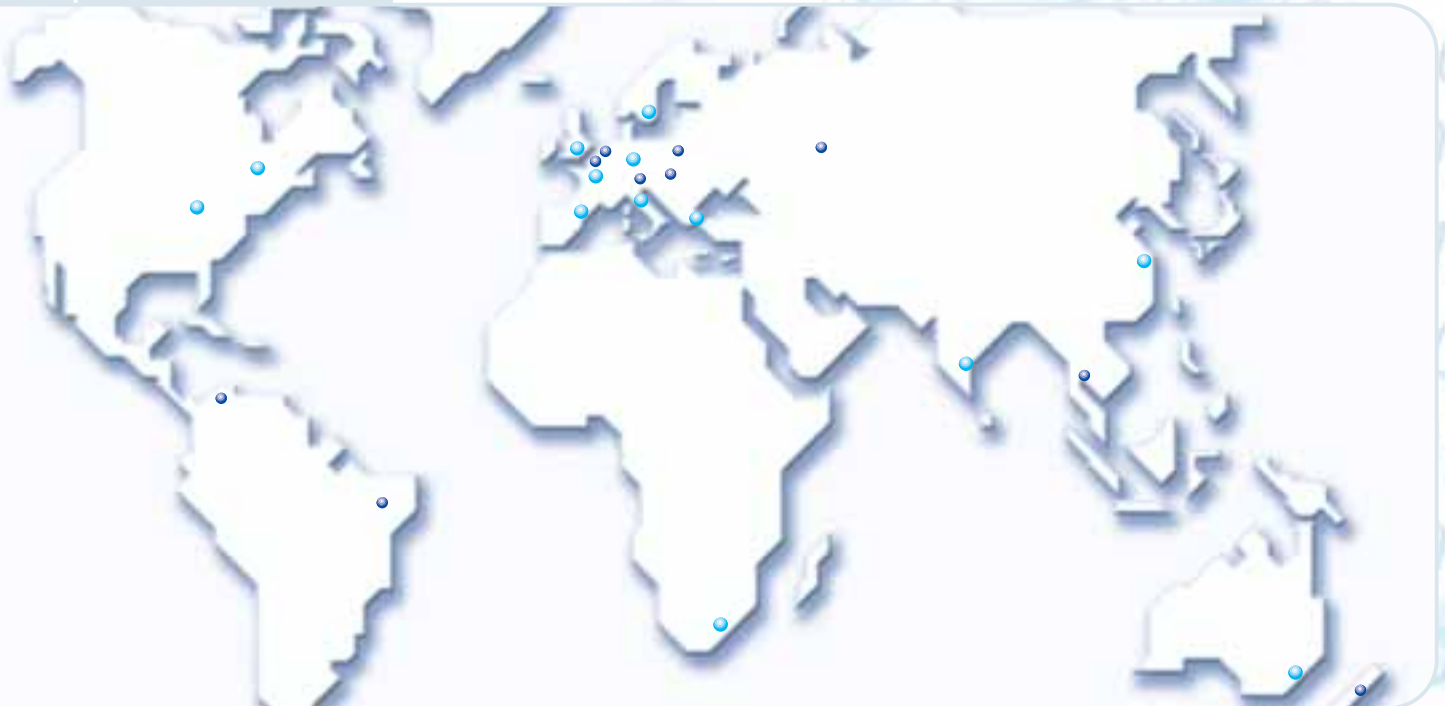

Bonfiglioli Worldwide & BEST Partners

AUSTRALIA

BONFIGLIOLI TRANSMISSION (Aust) Pty Ltd.
101, Plumpton Road, Glendenning NSW 2761, Australia
Locked Bag 1000 Plumpton NSW 2761
Tel. (+ 61) 2 8811 8000 - Fax (+ 61) 2 9675 6605
www.bonfiglioli.com.au - sales@bonfiglioli.com.au

AUSTRIA *BEST*

MOLL MOTOR GmbH
Industriestrasse 8 - 2000 Stockerau
Tel. (+43) 2266 63421+DW - Fax (+43) 6342 180
www.mollmotor.at - office@mollmotor.at

BELGIUM *BEST*

ESCO TRANSMISSION N.V./S.A.
Culliganlaan 3 - 1831 Machelem Diegem
Tel. 0032 2 7176460 - Fax 0032 2 7176461
www.esco-transmissions.be - info@esco-transmissions.be

BRASIL *BEST*

ATI BRASIL
Rua Omlio Monteiro Soares, 260 - Vila Fanny - 81030-000
Tel. (+41) 334 2091 - Fax (+41) 332 8669
www.atibrasil.com.br - vendas@atibrasil.com.br

CANADA

BONFIGLIOLI CANADA INC.
2-7941 Jane Street - Concord, Ontario L4K 4L6
Tel. (+1) 905 7384466 - Fax (+1) 905 7389833
www.bonfigliolicanada.com - sales@bonfigliolicanada.com

CHINA

BONFIGLIOLI DRIVES (SHANGHAI) CO. LTD.
No. 8 Building, 98 Tian Ying Road
Qingpu District, Shanghai, PRC 201712
Tel. +86 21 69225500 - Fax +86 21 69225511
www.bonfiglioli.cn - bds@bonfiglioli.com.cn

FRANCE

BONFIGLIOLI TRANSMISSIONS S.A.
14 Rue Eugène Pottier BP 19
Zone Industrielle de Moimont II - 95670 Marly la Ville
Tel. (+33) 1 34474510 - Fax (+33) 1 34688800
www.bonfiglioli.fr - btf@bonfiglioli.fr

GERMANY

BONFIGLIOLI DEUTSCHLAND GmbH
Hamburger Straße 18 - 41540 Dormagen
Tel. (+49) 2133 50260 - Fax (+49) 2133 502610
www.bonfiglioli.de - info@bonfiglioli.de

GREAT BRITAIN

BONFIGLIOLI UK Ltd
Industrial Equipment - Unit 3 Colemeadow Road
North Moons Moat - Redditch. Worcestershire B98 9PB
Tel. (+44) 1527 65022 - Fax (+44) 1527 61995
www.bonfiglioli-uk.com - salesindustrial@bonfiglioli-uk.com

Mobile Equipment
5 Grosvenor Grange, Woolston, Warrington
Cheshire WA1 4SF
Tel. (+44) 1925 852667 - Fax (+44) 1925 852668
www.bonfiglioli-uk.com - salesmobile@bonfiglioli-uk.com

GREECE *BEST*

B.E.S.T. HELLAS S.A.
O.T. 48A T.O. 230
C.P. 570 22, Industrial Area - Thessaloniki
Tel. (+30) 2310 796456 - Fax (+30) 2310 795903
www.bonfiglioli.gr - info@bonfiglioli.gr

HOLLAND *BEST*

ELSTO AANDRIJFTECHNIEK
Loosterweg, 7 - 2215 TL Voorhout
Tel. (+31) 252 219 123 - Fax (+31) 252 231 660
www.elsto.nl - info@elsto.nl

HUNGARY *BEST*

AGISYS AGITATORS & TRANSMISSIONS Ltd
2045 Törökbalint, Tó u.2. Hungary
Tel. +36 23 50 11 50 - Fax +36 23 50 11 59
www.agisys.hu - info@agisys.hu

INDIA

BONFIGLIOLI TRANSMISSIONS PVT Ltd.
PLOT AC7-AC11 Sidco Industrial Estate
Thirumudivakkam - Chennai 600 044
Tel. +91(0) 44 24781035 / 24781036 / 24781037
Fax +91(0) 44 24780091 / 24781904
www.bonfiglioli.co.in - bonfig@vsnl.com

ITALY

BONFIGLIOLI ITALIA srl
Via Sandro Pertini lotto 7b - 20080 Carpiano (Milano)
Tel. (+39) 02 985081 - Fax (+39) 02 985085817
customerservice.italia@bonfiglioli.it - www.bonfiglioli.it

NEW ZEALAND *BEST*

SAECO BEARINGS TRANSMISSION
36 Hastie Avenue, Mangere Po Box 22256, Otahuhu - Auckland
Tel. +64 9 634 7540 - Fax +64 9 634 7552
mark@saeco.co.nz

POLAND *BEST*

POLPACK Sp. z o.o. - Ul. Chrobrego 135/137 - 87100 Torun
Tel. 0048.56.6559235 - 6559236 - Fax 0048.56.6559238
www.polpack.com.pl - polpack@polpack.com.pl

PORTUGAL *BEST*

BT BONFITEC Equipamentos Industriais, Lda.
Largo do Colegio de Ermesinde, 70 - Formiga 4445-382 Ermesinde
Tel. 00351 229759634/5/6 - Fax 00351 229752211
bonfitec@bonfitec.pt - www.bonfitec.pt

RUSSIA *BEST*

FAM
57, Maly prospekt, V.O. - 199048, St. Petersburg
Tel. +7 812 3319333 - Fax +7 812 3271454
www.fam-drive.ru - info@fam-drive.ru

SPAIN

TECNOTRANS BONFIGLIOLI S.A.
Pol. Ind. Zona Franca sector C, calle F, nº6 08040 Barcelona
Tel. (+34) 93 4478400 - Fax (+34) 93 3360402
www.tecnotrans.com - tecnotrans@tecnotrans.com

SOUTH AFRICA

BONFIGLIOLI POWER TRANSMISSION Pty Ltd.
55 Galaxy Avenue, Linbro Business Park - Sandton
Tel. (+27) 11 608 2030 OR - Fax (+27) 11 608 2631
www.bonfiglioli.co.za - bonfigsales@bonfiglioli.co.za

SWEDEN

BONFIGLIOLI SKANDINAVIEN AB
Koppargatan 8 - 234 35 Lomma, Sweden
Tel. +46 40418230 - Fax +46 40414508
www.bonfiglioli.se - info@bonfiglioli.se

THAILAND *BEST*

K.P.T MACHINERY (1993) CO.LTD.
259/83 Soi Phiboones, Sukhumvit 71 Rd. Phrakhanong-nur,
Wattana, Bangkok 10110
Tel. 0066.2.3913030/7111998 - Fax 0066.2.7112852/3811308/3814905
www.kpt-group.com - sales@kpt-group.com

TURKEY

BONFIGLIOLI TURKIYE
Atatürk Organize Sanayi Bölgesi, 10015 Sk. No: 17, Çiğli - Izmir
Tel. +90 (0) 232 328 22 77 (pbx) - Fax +90 (0) 232 328 04 14
www.bonfiglioli.com.tr - info@bonfiglioli.com.tr

USA

BONFIGLIOLI USA, INC.
3541 Hargrave Drive Hebron, Kentucky 41048
Tel. (+1) 859 334 3333 - Fax (+1) 859 334 8888
www.bonfiglioliusa.com
industrialsales@bonfiglioliusa.com - mobilesales@bonfiglioliusa.com

VENEZUELA *BEST*

MAICA SOLUCIONES TECNICAS C.A.
Calle 3B - Edif. Comindu - Planta Baja - Local B
La Urbina - Caracas 1070
Tel. 0058.212.2413570 / 2425268 / 2418263
Fax 0058.212.2424552 - Tlx 24780 Maica V
maica1@cantv.net

HEADQUARTERS
BONFIGLIOLI RIDUTTORI S.p.A.
Via Giovanni XXIII, 7/A
40012 Lippo di Calderara di Reno
Bologna (ITALY)
Tel. (+39) 051 6473111
Fax (+39) 051 6473126
www.bonfiglioli.com
bonfiglioli@bonfiglioli.com

SPARE PARTS BONFIGLIOLI
B.R.T.
Via Castagnini, 2-4
Z.I. Bargellino - 40012
Calderara di Reno - Bologna (ITALY)
Tel. (+39) 051 727844
Fax (+39) 051 727066
www.brtonfiglioliricambi.it
brt@bonfiglioli.com



www.bonfiglioli.com

