

Adjustable handles for quick mounting

• Lever body

Glass-fibre reinforced polyamide based (PA) technopolymer. Resistant to solvents, oils, greases and other chemical agents.

• Colour

Grey-black with matte finish.

• Clamping element

Glass-fibre reinforced technopolymer in black colour with knurling on the projecting part to make initial mounting easier. Number of teeth "z" indicated in the table.

For quick mounting (Elesa Patent) six lobe socket ISO 10664 to fit TORX® T15 tool.

• Push button

Technopolymer in RAL 2004 orange with glossy finish. On request and for sufficient quantities it can be supplied in one of the other Ergostyle colours.

• Bushing

Brass with tapped blind hole.

• Axial retaining pin

Glass-fibre reinforced technopolymer.

• Return spring

AISI 302 stainless steel.

Applications

ERX.AV adjustable handles offer the possibility of a quick initial tightening by means of electric or pneumatic screwdrivers with controlled tightening torque systems. These handles are particularly suitable when the lever turning angle is limited owing to lack of space.

Instructions

To adjust during clamping, lift the lever to disengage clamping device toothing and bring it back to start position. By releasing the lever, the return spring automatically engages toothing once again.

Ergonomy and design

The slightly arched shape of the handle with the ergonomic terminal enlargement gives the operator a comfortable and safe grip, while the thumb rests naturally on the push button.

TORX® is a registered trade mark of TEXTRON Inc.

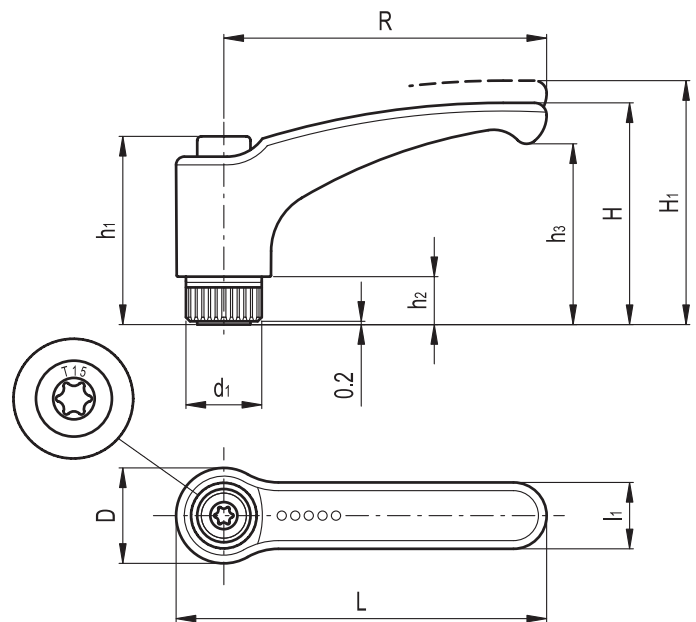
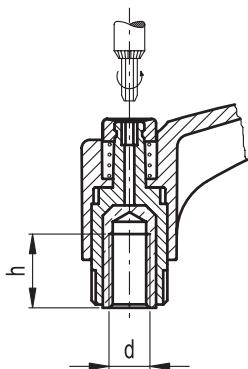

Standard elements		Main dimensions										Mounting hole		Teeth no.	Weight
Code	Description	R	L	D	H	H1	h1	h2	h3	d1	l1	d 6H	h	z	grams
233158-C2	ERX.78 AV B-M10-C2	78	90.5	23	54	58	45	12	44	19	16	M10	18	24	44
233163-C2	ERX.78 AV B-M12-C2											M12	17		43