

## Distance bushings



### • Material

AISI 303 stainless steel.

### Features and applications

St. Steel-Distance bushings GN 609.5 compensate for the body thread lengths on the indexing plungers to allow mounting through walls of varying thickness.

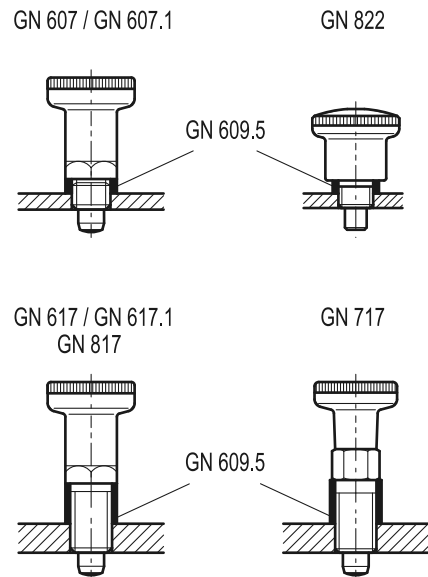
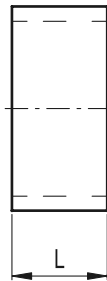
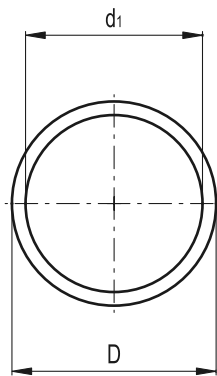

| Standard Elements | Main dimensions |        |        | For indexing plungers |                    |                    |        |        | ⚖ |
|-------------------|-----------------|--------|--------|-----------------------|--------------------|--------------------|--------|--------|---|
|                   | Description     | d1 H12 | D -0.1 | L ±0.1                | GN 607<br>GN 607.1 | GN 617<br>GN 617.1 | GN 717 | GN 817 |   |
| GN 609.5-8-10-2   | 8               | 10     | 2      | -                     | -                  | d=5                | d=4    | d=4/5  | 1 |
| GN 609.5-8-10-3   | 8               | 10     | 3      | -                     | -                  | d=5                | d=4    | d=4/5  | 1 |
| GN 609.5-8-10-4   | 8               | 10     | 4      | -                     | -                  | d=5                | d=4    | d=4/5  | 1 |
| GN 609.5-8-10-6   | 8               | 10     | 6      | -                     | -                  | d=5                | d=4    | d=4/5  | 1 |
| GN 609.5-8-10-8   | 8               | 10     | 8      | -                     | -                  | d=5                | d=4    | d=4/5  | 2 |
| GN 609.5-8-10-10  | 8               | 10     | 10     | -                     | -                  | d=5                | d=4    | d=4/5  | 2 |
| GN 609.5-10-12-2  | 10              | 12     | 2      | -                     | d=5                | d=6                | d=5    | d=6/7  | 1 |
| GN 609.5-10-12-4  | 10              | 12     | 4      | -                     | d=5                | d=6                | d=5    | d=6/7  | 1 |
| GN 609.5-10-12-6  | 10              | 12     | 6      | -                     | d=5                | d=6                | d=5    | d=6/7  | 2 |
| GN 609.5-10-12-8  | 10              | 12     | 8      | -                     | d=5                | d=6                | d=5    | d=6/7  | 2 |
| GN 609.5-10-12-10 | 10              | 12     | 10     | -                     | d=5                | d=6                | d=5    | d=6/7  | 3 |
| GN 609.5-10-12-12 | 10              | 12     | 12     | -                     | d=5                | d=6                | d=5    | d=6/7  | 3 |
| GN 609.5-12-14-2  | 12              | 14     | 2      | -                     | d=6                | d=8                | d=6    | -      | 1 |
| GN 609.5-12-14-4  | 12              | 14     | 4      | -                     | d=6                | d=8                | d=6    | -      | 1 |
| GN 609.5-12-14-6  | 12              | 14     | 6      | -                     | d=6                | d=8                | d=6    | -      | 2 |
| GN 609.5-12-14-8  | 12              | 14     | 8      | -                     | d=6                | d=8                | d=6    | -      | 2 |
| GN 609.5-12-17-2  | 12              | 17     | 2      | d=6                   | -                  | -                  | -      | -      | 2 |
| GN 609.5-12-17-4  | 12              | 17     | 4      | d=6                   | -                  | -                  | -      | -      | 3 |
| GN 609.5-12-17-5  | 12              | 17     | 5      | d=6                   | -                  | -                  | -      | -      | 4 |
| GN 609.5-16-17-4  | 16              | 17     | 4      | -                     | -                  | -                  | d=8/10 | -      | 1 |
| GN 609.5-16-17-6  | 16              | 17     | 6      | -                     | -                  | -                  | d=8/10 | -      | 1 |
| GN 609.5-16-17-8  | 16              | 17     | 8      | -                     | -                  | -                  | d=8/10 | -      | 1 |
| GN 609.5-16-17-10 | 16              | 17     | 10     | -                     | -                  | -                  | d=8/10 | -      | 2 |
| GN 609.5-16-17-12 | 16              | 17     | 12     | -                     | -                  | -                  | d=8/10 | -      | 2 |
| GN 609.5-16-19-2  | 16              | 19     | 2      | d=8                   | d=8                | -                  | -      | -      | 1 |
| GN 609.5-16-19-4  | 16              | 19     | 4      | d=8                   | d=8                | -                  | -      | -      | 2 |
| GN 609.5-16-19-6  | 16              | 19     | 6      | d=8                   | d=8                | -                  | -      | -      | 4 |
| GN 609.5-16-19-8  | 16              | 19     | 8      | d=8                   | d=8                | -                  | -      | -      | 5 |
| GN 609.5-16-19-10 | 16              | 19     | 10     | d=8                   | d=8                | -                  | -      | -      | 6 |
| GN 609.5-16-19-12 | 16              | 19     | 12     | d=8                   | d=8                | -                  | -      | -      | 7 |