

GN 712

Cam action indexing plungers

- **Material**
Zinc-plated steel.
- **Plunger**
Nitrided steel.
- **Bolt**
Technopolymer, black colour, matte finish, not removable.
- **Standard executions available**
 - Execution **A**: without rest position, without nut.
 - Execution **AK**: without rest position, with lock nut.
 - Execution **R**: with rest position, without lock nut.
 - Execution **RK**: with rest position and lock nut.
 - Execution **S**: with safety-rest position and without lock nut.
 - Execution **SK**: with safety-rest position and lock nut.

Special executions on request (For sufficient quantities)

Stainless steel cam action indexing plungers GN 712.5.

Features and applications

Cam action indexing plungers GN 712 are used in such applications where the plunger must not protrude continually. When turning the cam by 90 resp. 120 degrees in anti-clockwise direction, the plunger is moved through a curved opening in the body. After that, the plunger is protruding.

Depending on the type, the plunger is moved back by a spring in its original position (execution **A**), is held in protruding position (execution **R**), resp. is secured against accidental operation (execution **S**).

In order to move the plunger, safety version Execution **S** requires an additional lifting of the bolt.

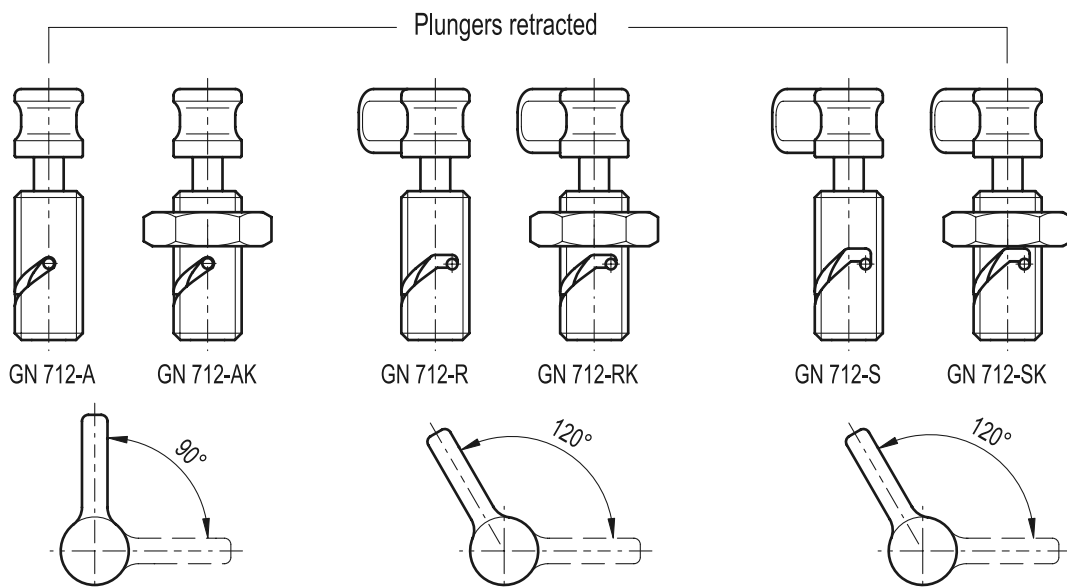

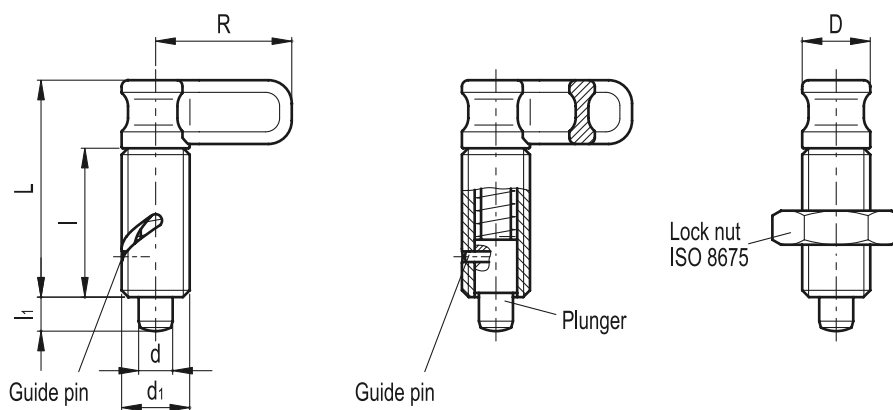

Standard Elements	Main dimensions							Spring pressure	
	Description	$d_{-0.04}^{-0.02}$	d_1	D	L~	l_{min}	l_1	R	Preload [N~]
GN 712-6-M16x1.5-A	6	M16x1.5	16	51	35	8	32	6.5	20
GN 712-8-M16x1.5-A	8	M16x1.5	16	51	35	8	32	6.5	20
GN 712-10-M16x1.5-A	10	M16x1.5	16	51	35	8	32	6.5	20
GN 712-6-M16x1.5-AK	6	M16x1.5	16	51	35	8	32	6.5	20
GN 712-8-M16x1.5-AK	8	M16x1.5	16	51	35	8	32	6.5	20
GN 712-10-M16x1.5-AK	10	M16x1.5	16	51	35	8	32	6.5	20
GN 712-6-M16x1.5-R	6	M16x1.5	16	51	35	8	32	6.5	20
GN 712-8-M16x1.5-R	8	M16x1.5	16	51	35	8	32	6.5	20
GN 712-10-M16x1.5-R	10	M16x1.5	16	51	35	8	32	6.5	20
GN 712-6-M16x1.5-RK	6	M16x1.5	16	51	35	8	32	6.5	20
GN 712-8-M16x1.5-RK	8	M16x1.5	16	51	35	8	32	6.5	20
GN 712-10-M16x1.5-RK	10	M16x1.5	16	51	35	8	32	6.5	20
GN 712-6-M16x1.5-S	6	M16x1.5	16	51	35	8	32	6.5	20
GN 712-8-M16x1.5-S	8	M16x1.5	16	51	35	8	32	6.5	20
GN 712-10-M16x1.5-S	10	M16x1.5	16	51	35	8	32	6.5	20
GN 712-6-M16x1.5-SK	6	M16x1.5	16	51	35	8	32	6.5	20
GN 712-8-M16x1.5-SK	8	M16x1.5	16	51	35	8	32	6.5	20
GN 712-10-M16x1.5-SK	10	M16x1.5	16	51	35	8	32	6.5	20