

GN 900.6

Rotary tables

- **Rotary disc**
AISI 303 stainless steel.
- **Operating knob**
Black anodised aluminium.
- **Other parts**
Rustproof steel

Features and applications

Rotary tables GN 900.6 is a turning unit for manual operation. To get the turning movement we use a high quality worm gear.

The rotary table is also fitted with a fast adjustment and for this purpose a grub screw on the side of the rotary disc has to be released. In addition the rotary disc can also be clamped via an easily accessible grub screw. In both cases internal conically shaped arresting components come into use.

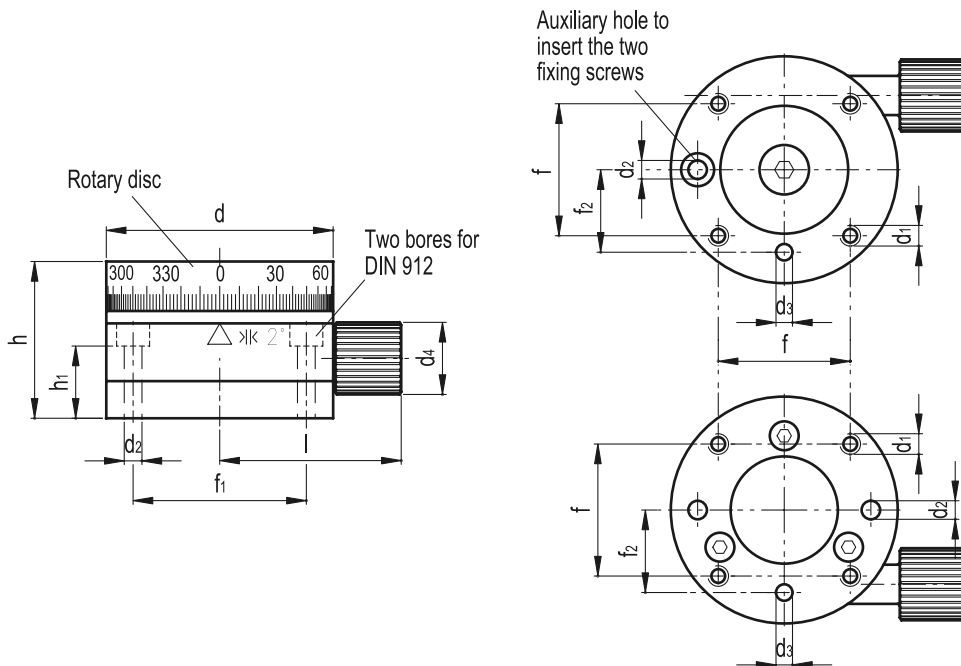
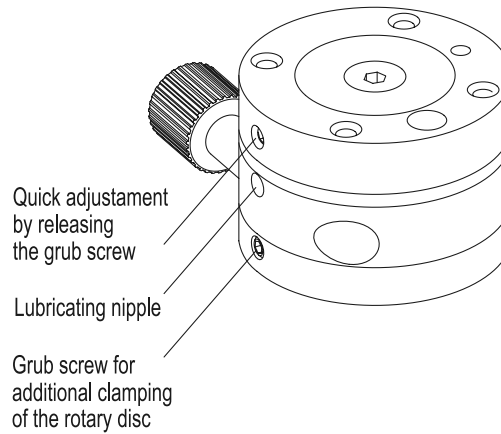

Standard Elements	Main dimensions										
Description	d H7	d1	d2	d3 H7	d4	h	h1	l	f	f1	f2 ±0.02
GN 900.6-55	55	8	4.3	4	17	38	17.5	44	32	42	20
GN 900.6-88	88	8	5.4	4	23	42	24	59	40	60	30