

A detailed close-up photograph of a HEPCO DTS driven track system. The image shows a complex assembly of precision-machined metal components. A central feature is a long, dark-colored track with a series of small, evenly spaced holes along its length. This track is supported and guided by several rectangular metal brackets, which are secured with screws. The brackets are mounted on a sturdy metal frame. In the foreground, a large, circular metal flange or pulley is visible, which is part of the drive mechanism. The background is a solid, vibrant green color, which makes the metallic parts stand out. The overall appearance is that of a high-precision industrial machine.

HEPCO

DTS
driven track system

Introducing the Hepco DTS – Driven Track System

Complementary to the Hepco Ring Slides & Track System*, the DTS is a ready-assembled unit providing a facility to drive Hepco carriages around a Hepco Track circuit under either continuous or intermittent motion. At all times the carriages are rigidly guided along the precision track and can thus maintain accurate alignment and resist deflection from external loads.

The carriages are usually positioned at equal pitches as specified by the customer and are connected to a high strength timing belt.

Aware that customer's integrated equipment could be damaged in the event of a jam, Hepco have devised an ingenious Trip Latch mechanism which allows each carriage to disengage from the drive belt if motion is impeded.

The DTS has been designed with no protrusions above the level of the carriage mounting surface to enable customer's fixtures or components to overhang the carriages if required, and also to allow clear access for loading purposes. The design allows plenty of space for the accommodation of other equipment including effective guarding of the mechanism.

The DTS is supplied by Hepco as a complete unit, ready to be incorporated into the customer's machine or framework. It is compatible with the Hepco MCS Machine Construction System** and can therefore be supplied as a free-standing unit if required.

The system is available with either an AC Geared Motor or a Gearbox with an IEC flange suitable for many motor choices. A plain output shaft is also available to enable customers to attach indexing units or other drive sources.

The DTS comes in two basic sizes incorporating Track System sizes 25 and 44 (see Hepco Ring Slides & Track System catalogue for details). Each size of DTS is available in either:

Oval circuit format



or

Rectangular circuit format

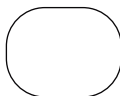

The lower cost oval circuit is of fixed width, whilst the rectangular circuit may be ordered to any width above the minimum prescribed.

Both types of circuit can be ordered to any length above the minimum prescribed.

(See dimensions W and L pages 5 & 6).

Applications utilising intermittent motion will benefit from the Hepco Carriage Locking System which can be provided along any straight section of the circuit to precisely position and lock the required number of carriages at their stationary positions. Customers can therefore rely on precise location of their components whilst other operations take place.

* Ref. Hepco catalogue: 'Ring Slides and Track System'

** Ref. Hepco catalogue: 'MCS Machine Construction System'

High Tensile 10mm Pitch Timing Belt with drive profiles attached to the belt at the desired spacing, transmits power to the carriages.

Track Sizes * provided for the DTS are: 25 mm track width with 351 diameter segments Ref. DTS25-351 and 44 mm track width with 612 diameter segments Ref. DTS44-612.

Carriages of the 'fixed centre' type * are used on the DTS pitched at 10 mm increments from a minimum of: 110 mm on the 25-351 size system, 160 mm on the 44-612 size system.

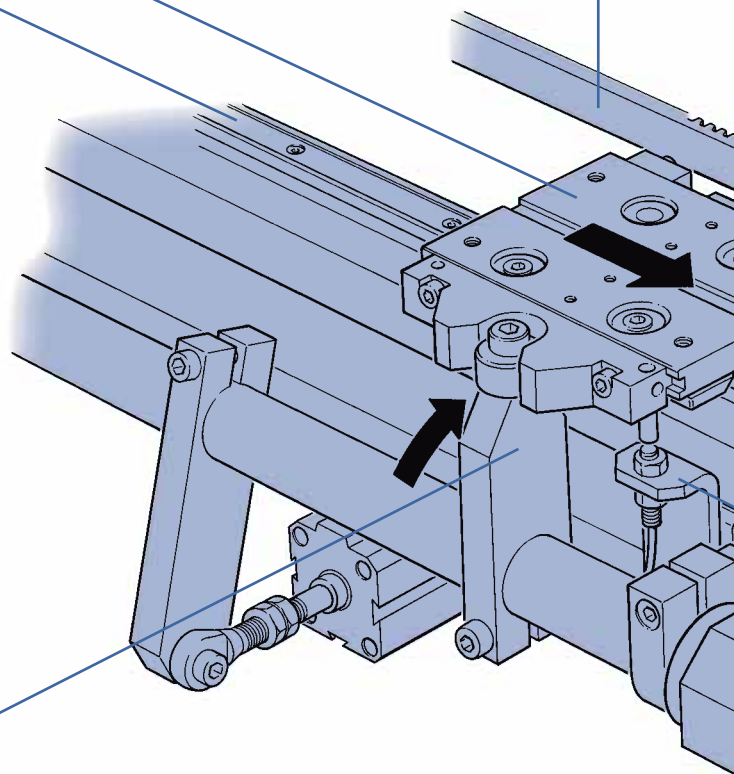

Carriage Locking System (optional with intermittent motion): Aligns specific carriages to a repeatable position anywhere along any straight section of the circuit to ± 0.05 mm.

The slight compliance of the belt allows each carriage to be guided to its exact stop position by cam roller.

Individual or multiple locking devices can be operated by a single air cylinder (air service unit, valves and restrictors not provided). The stationary position of each individual carriage can be adjusted to precise requirements by simply unclamping and moving the locking arm. Complete repositioning of carriages can also be achieved.

System Composition

Pulley Bearing Units - with sealed bearing cartridges can be adjusted to provide tension for the belt. The bearings are 'greased for life'. Any one of the pulley bearing units may be specified as the drive unit, which will then incorporate a 25 mm diameter plain shaft extension for motor mounting or for the attachment of other power sources. More than one drive unit per system may be specified. Drive pulleys have teeth, idler pulleys are plain.

The drive motor may be selected from a range of compatible AC Geared Motors supplied by Hepco. Alternatively, customers may choose from a range of gearboxes with IEC flanges suitable for connection to other motors (see page 8).

Trip Latches - transmit the drive from the belt to the carriages and can be set to trip out of engagement at any force up to 60N thus protecting customer's integrated equipment. When disengaged, the trip arms clear the belt and remain in their retracted positions until manually re-engaged.

Customers requiring early warning of a disengaged carriage should fit proximity sensors at frequent positions around the circuit.

Customers are advised to choose the standard Trip Latch safety system, where loads permit. Lower cost fixed belt/carriage connectors are also available.

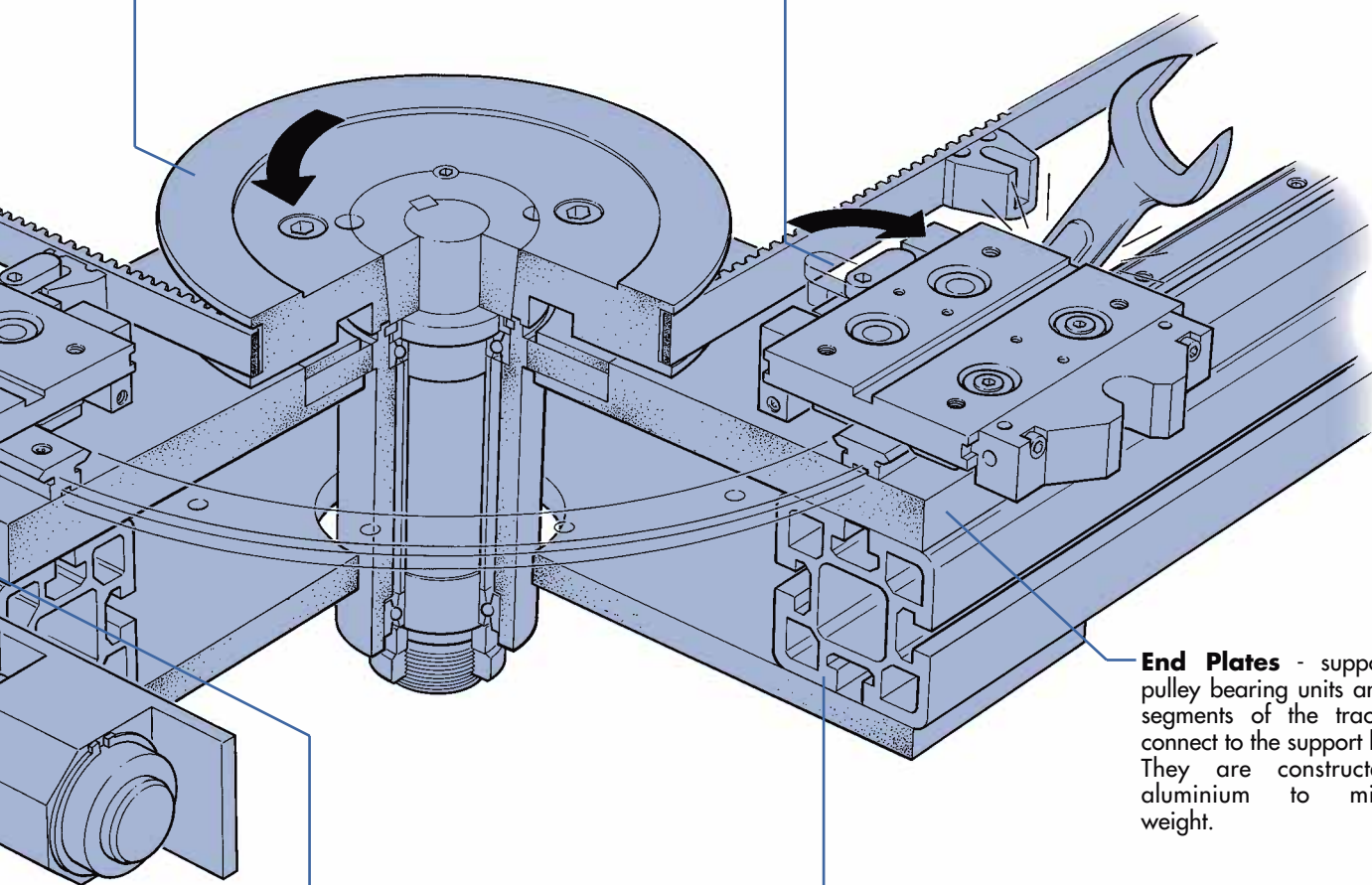

Sensor Mounting Brackets (optional)

- can be positioned anywhere along a straight section and are available from Hepco to suit M8 threaded proximity switches (not supplied).

Intermittent motion will normally require PLC control via outputs from proximity sensors at the stop positions. Proximity sensors are also necessary to warn of carriage disengagement when using the recommended Trip Latch carriage/belt connection system.

The carriage locking cam houses the actuator for the proximity switches. If the Carriage Locking System is not required, dedicated proximity switch actuators may need to be specified (see page 10).

End Plates - support the pulley bearing units and ring segments of the track and connect to the support beams. They are constructed in aluminium to minimise weight.

Support Beams

- form the framework of the DTS and comprise of a special high precision aluminium extrusion to support the straight sections of the track. The support beam is compatible with the MCS Machine Construction System**.

The beams feature T slots to accept a variety of fastenings available for attaching customer's components. A plastic cover strip is available to close off the T slots and provide a routing for wiring.

Large DTS units will incorporate aluminium profile cross members for reasons of strength and for ease of attachment of customer's equipment.

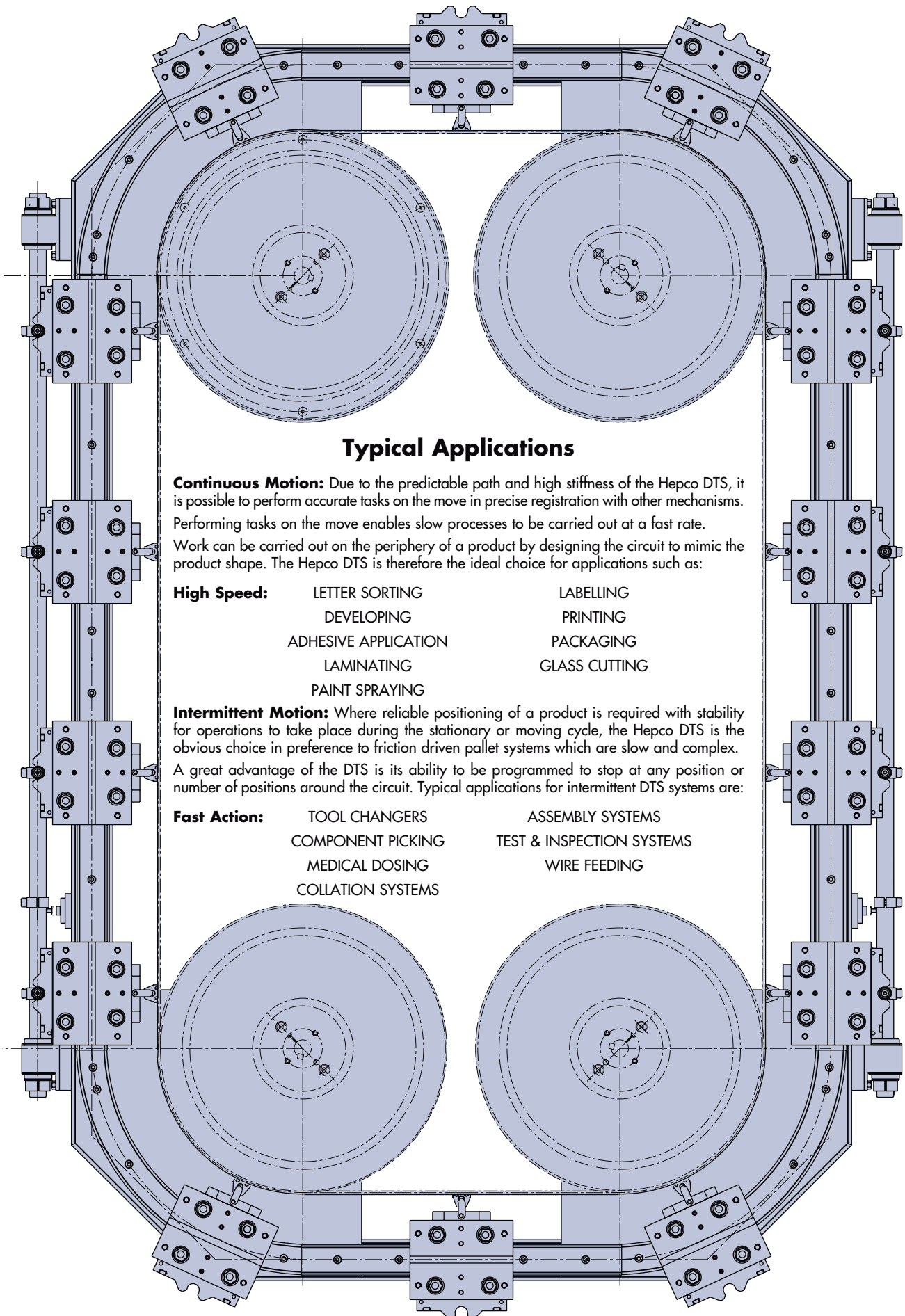

Typical Applications

Continuous Motion: Due to the predictable path and high stiffness of the Hepco DTS, it is possible to perform accurate tasks on the move in precise registration with other mechanisms. Performing tasks on the move enables slow processes to be carried out at a fast rate. Work can be carried out on the periphery of a product by designing the circuit to mimic the product shape. The Hepco DTS is therefore the ideal choice for applications such as:

High Speed:

LETTER SORTING	LABELLING
DEVELOPING	PRINTING
ADHESIVE APPLICATION	PACKAGING
LAMINATING	GLASS CUTTING
PAINT SPRAYING	

Intermittent Motion: Where reliable positioning of a product is required with stability for operations to take place during the stationary or moving cycle, the Hepco DTS is the obvious choice in preference to friction driven pallet systems which are slow and complex. A great advantage of the DTS is its ability to be programmed to stop at any position or number of positions around the circuit. Typical applications for intermittent DTS systems are:

Fast Action:

TOOL CHANGERS	ASSEMBLY SYSTEMS
COMPONENT PICKING	TEST & INSPECTION SYSTEMS
MEDICAL DOSING	WIRE FEEDING
COLLATION SYSTEMS	

Applications

Application Example

Optical Lens Assembly

Lenses are loaded by pick and place units onto clamp fixtures mounted on each Hepco carriage.

The top carriages are accurately located using the Hepco Carriage Locking System.

Optical adhesive is applied between the lenses, which then pass through an ultra violet light box to activate the hardener.

The lenses are finally inspected for optical clarity and then released onto an accept or reject conveyor. On the return, the empty fixtures are brushed clean.

The vertical orientation of the system allows excess adhesive to drip onto a collector and lenses to be ejected from the system by gravity thus avoiding the cost of further pick and place units.

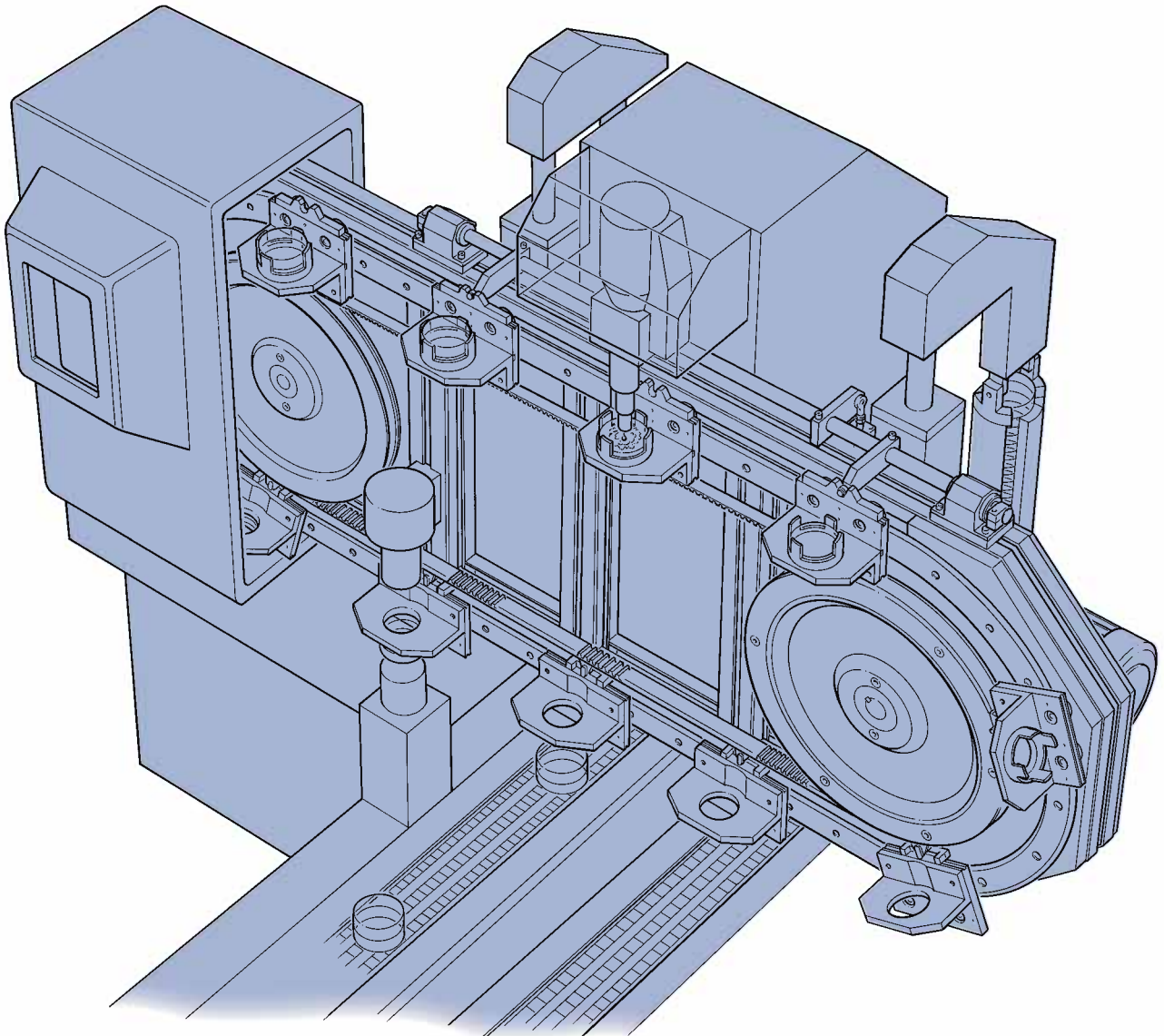

Data & Dimensions

DTS - 25 - 351

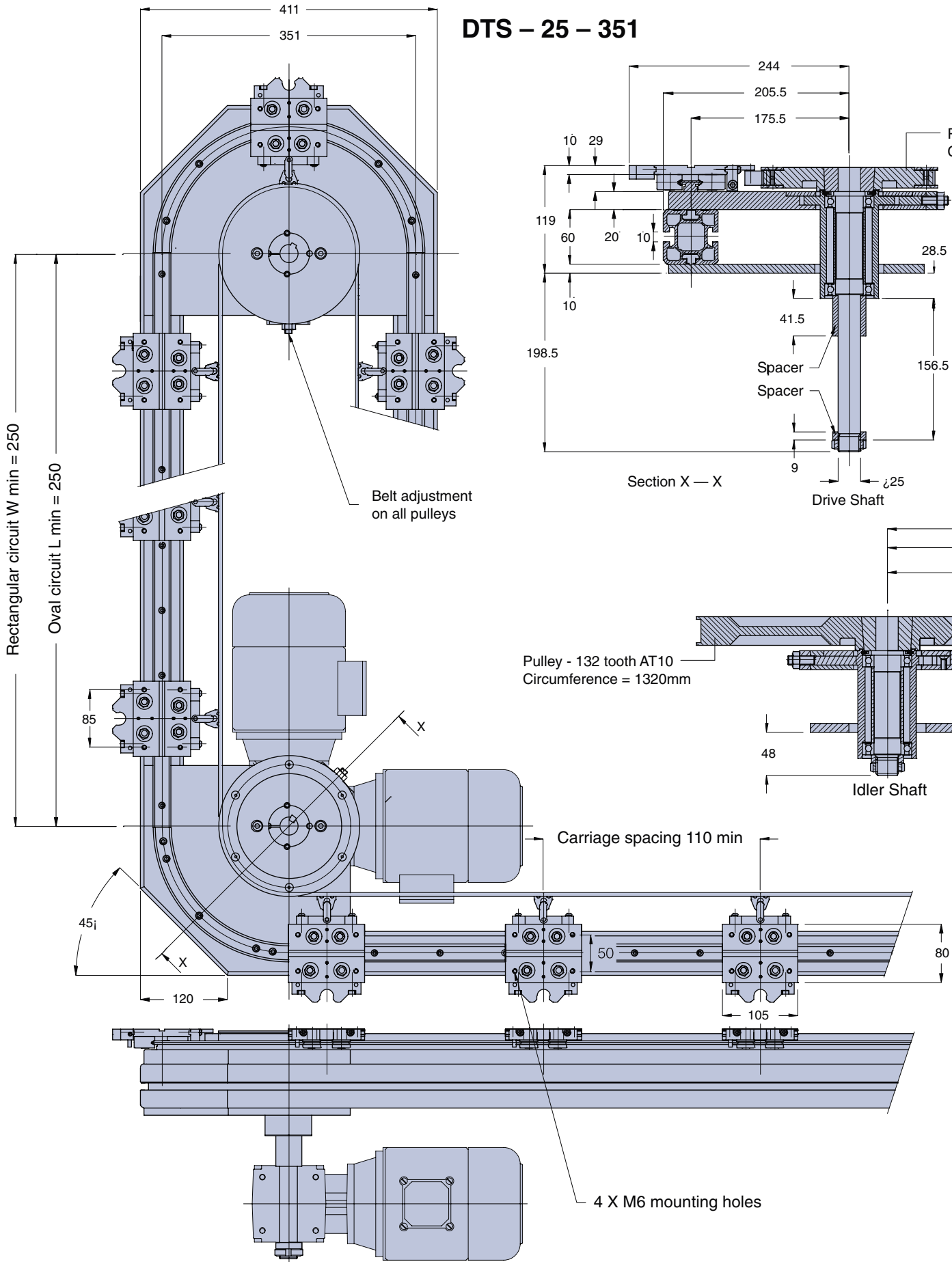

For Carriage Locking

Data & Dimensions

DTS - 44 - 612

tooth - 60 tooth AT10
circumference = 600mm

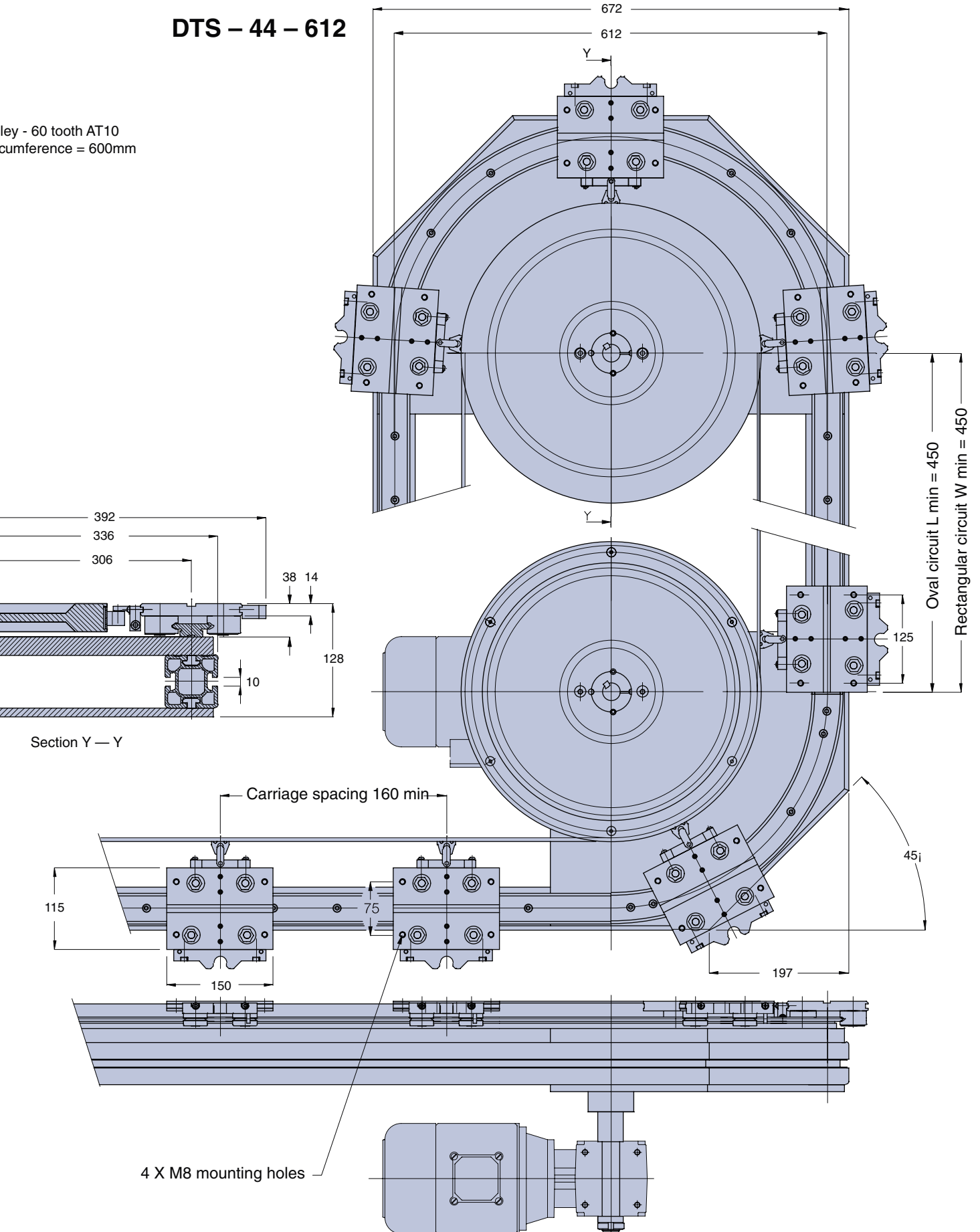

System see page 9

Selection and Specification

Dynamic parameters

Excess speed combined with overloading of the carriages can result in disengagement of the trip latches at the bends where the carriages rapidly accelerate and decelerate. Maximum speed will also be affected if the centre of gravity of the carriage load overhangs externally, or if the system is configured in the vertical plane.

Some high-speed applications may benefit from the optional fixed method of connection from belt to carriage, in which case a torque limiter on the primary drive should be considered. Such overload protection may not be sufficiently sensitive to avoid damage.

There is no fundamental limit to the number of carriages in a system, for instance 50 carriages each carrying a reasonable load may well be acceptable. Also, there is no fundamental limit to the length of track although support beams may need to be joined.

In all cases it is important to inform Hepco of the complete dynamic and static data relating to your application including the effect of raising and lowering carriages if the track is to be configured vertically.

Specifying system parameters

1 Specify dynamic parameters

Carriage load.

External forces.

Full velocity profile including accelerations, dwells, speeds, duty cycle and required life.

2 Make an initial selection

Consider the physical size and weight of the component to be carried and make an initial selection of system size.

Parts mounted to the carriage can overhang the sides as the design allows clearance.

As a guide to weights a size 25 carriage would typically be used up to 20 kg with 40 kg being usual for size 44.



Both systems can carry higher loads than this (see Hepco Ring Slides and Track System catalogue, page 24) and static loads of 200 and 400kg respectively are possible.

3 Calculate the carriage static and dynamic loadings

Use the Hepco Ring Slides and Track System catalogue pages 24-27 to determine if the initial choice of carriage is suitable for the application making reference to the 'lubricated condition'.

Laying out the track

4 Choose the track shape required

Oval  or Rectangular 

and specify the drive unit position(s) 1 to 4.

5 Choose the number of carriages you require

An even number of carriages will usually be selected in order to produce a symmetrical carriage layout.

6 Select the carriage spacing

The spacing must be in 10 mm increments. Carriages will usually be spaced equally apart.

Minimum spacing for a standard carriage

DTS25-351 = 110

DTS44-612 = 160

7 Calculate the overall dimensions of the system given:

N = number of carriages

S = carriage spacing (ignoring belt stretch)

L = System length (between centres of pulleys)

W = System width (between centres of pulleys)

Oval system

DTS 25-351 $NS = 0.998 \times (2L + 600)$

DTS 44-612 $NS = 0.998 \times (2L + 1320)$

Rectangular system

DTS 25-351 $NS = 0.998 \times (2L + 2W + 600)$

DTS 44-612 $NS = 0.998 \times (2L + 2W + 1320)$

Note: The above equation yield approximate answers. Hepco will size systems exactly prior to manufacture.

If the calculated length is not in line with requirements, select an alternative number of carriages or carriage spacing and recalculate.

If a mechanical indexer is used as a drive source or the DTS is integrated into the customer's machine, drive ratios may have to be considered.

8 Check the trip load of each carriage

Using conventional mechanical calculations, allowing for friction, external load and acceleration (inertial force) ensure that at no time does the linear force on any single carriage exceed 60N. If this does occur then the trip latches will disengage and the carriages will become disconnected from the belt.

Inertial disengagement limits

The carriages on a DTS system travel faster on the curved section than on the straights. As each carriage moves between straight and curve, acceleration produces an inertial reaction force on the trip latch. This means that for any given mass on a carriage, there is a maximum speed (measured on the straights see graph below) beyond which carriages are liable to disengage.

The fixed carriage/belt connection may allow the 60N force to be exceeded. Please consult Hepco.

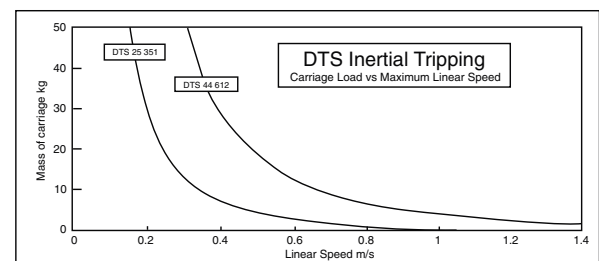

Specifying drive source & control

9 Select a suitable drive source

Hepco supply, as an optional extra, a comprehensive range of Geared AC Motors and drives and worm gearboxes for direct coupling to the DTS.

Some common selections together with performance data are shown in the table (above right).

Selection and Specification

Additional sizes and more detailed information can be found in Hepco's DLS (Driven Linear Transmission and Positioning System) catalogue Ref. DLS03.

Note that considerably higher linear forces can be achieved by incorporating more than one drive unit utilising geared motors of the WG7 design. This configuration gives the advantage of sharing the drive load between pulley bearing units. Alternatively, Hepco can supply the DTS drive unit shaft(s) prepared to receive the customer's drive source.

DTS 25 – 351 with AC Geared Motor

Nominal Linear Speed @ 50Hz m/s	Working Speed Range m/s	Nominal Linear Force N	Motor Power kW	Motor Type	Gearbox Ratio	Gearbox Rated Linear Force
0.19	0.02 - 0.3	726	0.25	71L/6	48	829
0.41	0.04 - 0.65	829	0.55	80S/4	34	889
0.73	0.07 - 1.15	754	0.75	80L/4	19	862
1.52	0.15 - 2.4	584	1.1	90L/6	6	877

DTS 44 – 612 with AC Geared Motor

Nominal Linear Speed @ 50Hz m/s	Working Speed Range m/s	Nominal Linear Force N	Motor Power kW	Motor Type	Gearbox Ratio	Gearbox Rated Linear Force
0.31	0.03 - 0.5	300	0.18	71S/6	63	321
0.42	0.04 - 0.68	330	0.25	71L/6	48	377
0.64	0.07 - 1.0	330	0.37	71L/4	48	377
1.06	0.11 - 1.7	381	0.55	80L/6	19	409
1.61	0.16 - 2.5	343	0.75	80L/4	19	392

The DTS will produce the Nominal Linear force at speeds ranging from 50% to 100% of the Nominal Linear Speed.

The DTS will perform with a lower force and duty cycle over a much wider speed range from 10% to 160% of the Nominal Linear Speed.

The Gearbox Rated Linear Force is the force produced when the gearbox is on a service factor of 1.4. This is based upon a fast operation for 8 hours per day. Allowable forces can be increased if the application is less arduous than this.

Please contact Hepco's Technical Department for details.

Motor/Gearbox dimensions

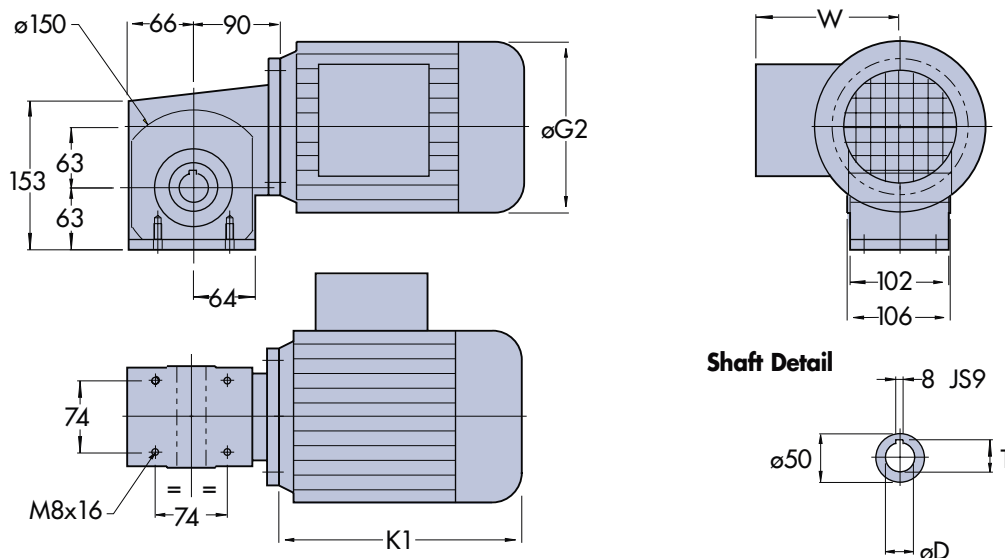

Type of gear unit	Type of Motor	Motors			Gearbox		Weight/kg of motor & gearbox
		G2	K1	W	D H7	T	
WG7	71S/L	138	212	125	25	28.3	13.5
	80S/L	156	233	137	25	28.3	16.9
	90L	176	275	147	30	33.3	22.3

Optional Equipment

Carriage Locking System

Specify the stations on the circuit where you require carriages to be locked in position.

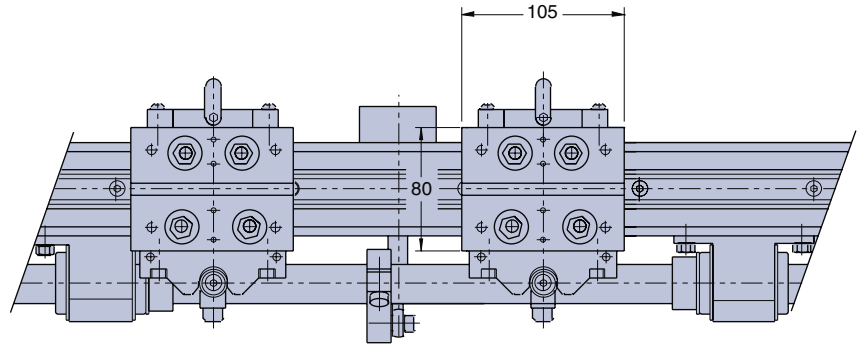
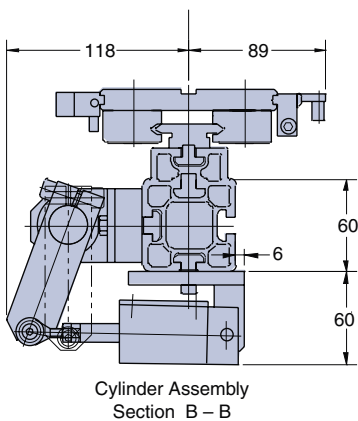
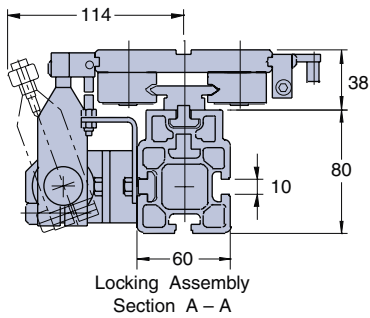
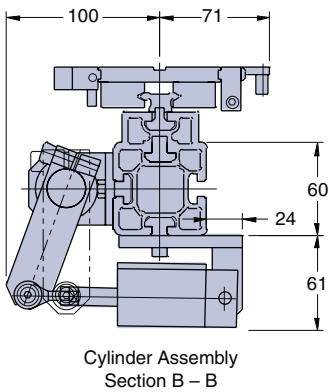
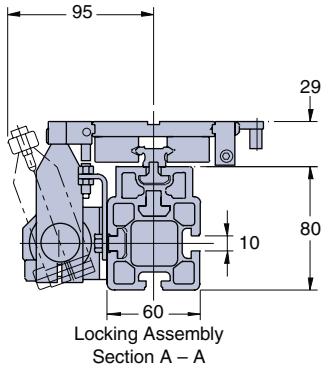

DTS - 25

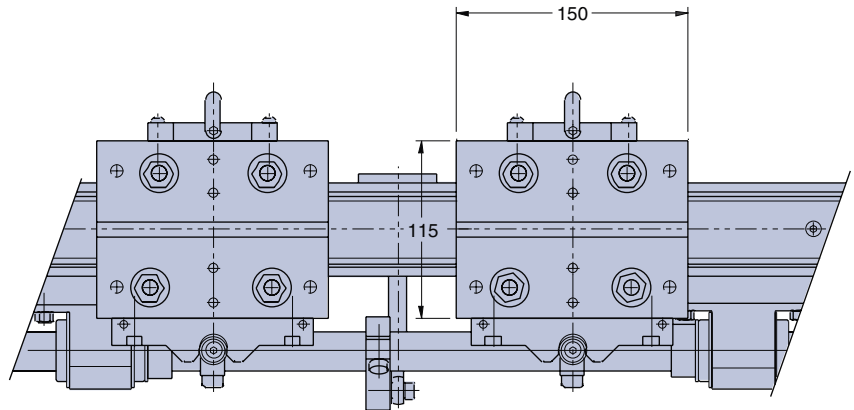
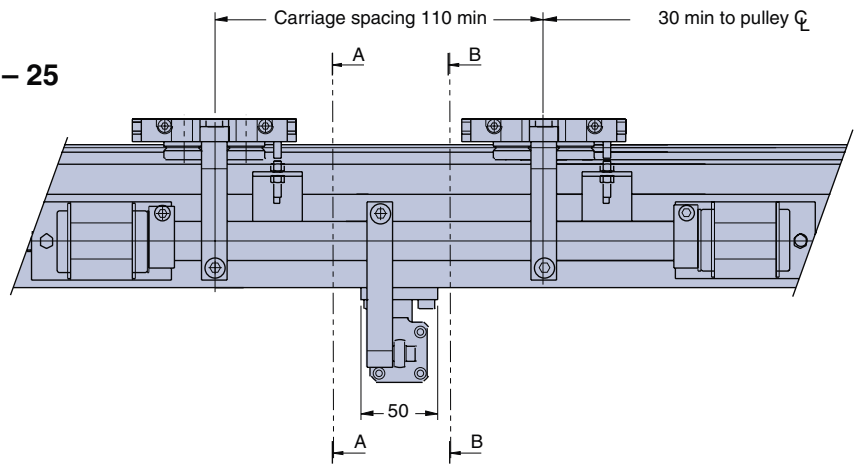

DTS - 44

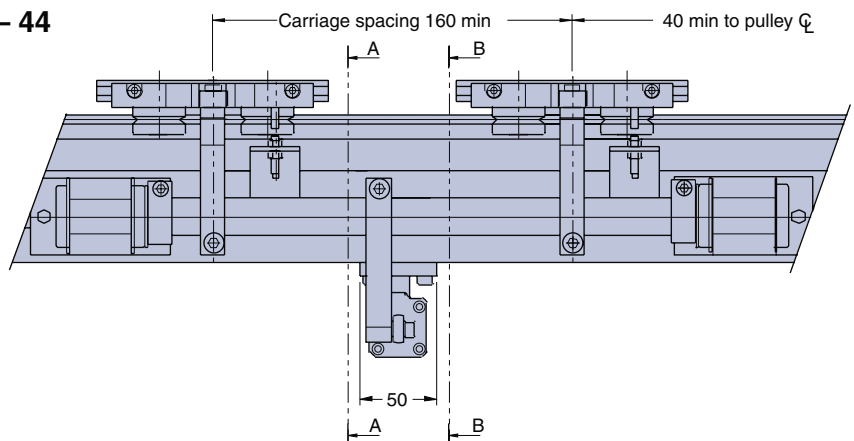

Optional Equipment

Motor options (supplied by Hepco)

Electro Magnetic Brake.
Torque Limiter.
Programmable variable speed AC Drive.

Special gearbox flange for customer's own motor
(Contact Hepco for details).

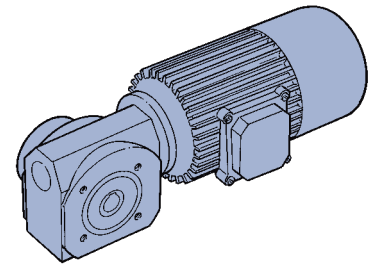

Dedicated Proximity Switch Actuators

Required if proximity switches are to be used without a carriage locking system. Normally fitted to each carriage.

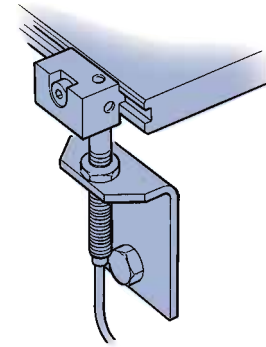

Sensor Mounting Brackets

Specify the number of brackets and their positions, if required to be fitted.

Fixed Belt/Carriage Connectors

Alternative to trip latches.

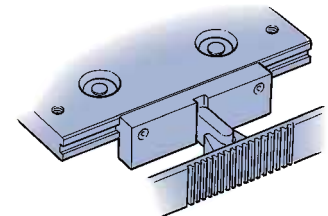

T-nuts/T-bolts

Specify quantity and part number.

T slot Covers

Specify part number and length in mm.

Special Drive Shaft

The drive shaft is plain and nominally 25 mm diameter.
If you require a keyway or reduced shaft diameter please specify details.

Extra Length Carriages

Specify length in mm and mounting hole details.
Note: Bearing assembly mounting holes and positions cannot be altered.
(Ref. Hepco Ring Slides and Track System catalogue).

MCS Machine Construction System Support Frame

Supply a drawing of the frame.
(Ref. Hepco MCS Machine Construction System catalogue).

FLANGE NUT	PART NO.
M8 x 17A 8B	1-242-1101
M8 x 19A 10B	1-242-1100

T-BOLT	PART NO.
M8 x 13L*	1-242-1009
M8 x 18L*	1-242-1000
M8 x 33L*	1-242-1006

T-NUTS	PART NO.
M4	1-242-1029
M5	1-242-1030
M6	1-242-1001
M8	1-242-1002

T-BLOCK	PART NO.
M5	1-242-1031
M6	1-242-1013
M8	1-242-1032

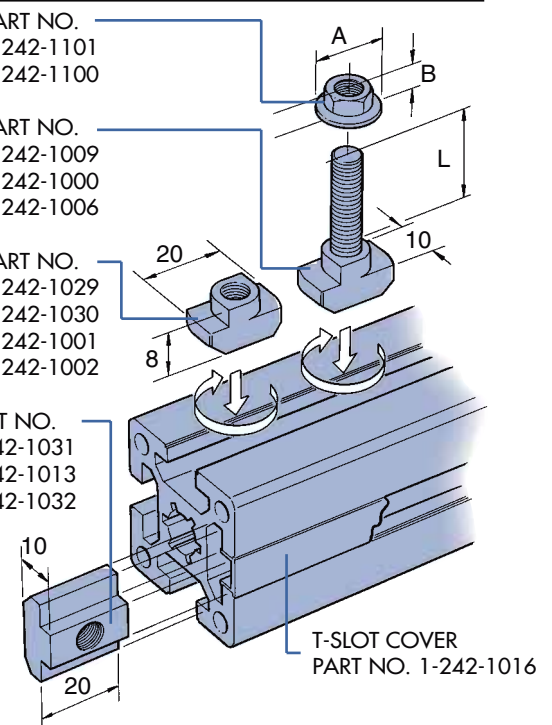

SUBMIT DATA REQUIRED (PAGES 7 TO 10) AND YOU WILL RECEIVE YOUR SYSTEM LAYOUT

Operational Safety

Since the DTS is a mechanism which forms part of a larger machine a CE mark is not required, but each unit is supplied with a Declaration of Incorporation which will enable the machine builder to include it as part of the CE marking criteria for his complete machine. The operating instructions, mechanical guarding and electrical safety are the responsibility of the user incorporating the DTS into their machine, and these should be designed in line with the requirements outlined in the Certification of Incorporation. It is not intended that the Trip Latch be considered a safety device other than for the protection of the machine itself.



GV3
Linear Guidance and
Transmission System



HDS
Heavy Duty Slide System

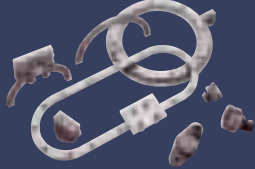

Ring Slides and
Track System



HDLS
Heavy Duty
Driven Linear Systems



HPS
Powerslide-2 Guided
Rodless Cylinder



SL2
Stainless Steel Based
Slide System



DLS
Linear Transmission and
Positioning System



Utilitrak
Lightweight U Channel
Guideway



LoPro
Aluminium Based
Slide System



FB
Fastline Ballscrews



DTS
Driven Track System

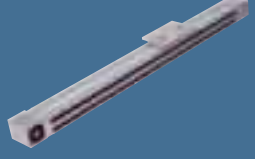

PDU2
Aluminium Profile
Driven Unit



Dual Vee
Single Edge Slide System



SH
Shock Absorbers

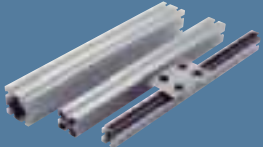

MCS
Aluminium Frame and
Machine Construction System



Simple Select
Vee Slide Linear
Guidance Systems



**Hepco products are available worldwide -
please request our catalogue FPL
or visit our website:
www.hepco.co.uk**



Guiding You Towards the Future

Hepco Slide Systems Ltd
Lower Moor Business Park, Tiverton Way
Tiverton, Devon, England EX16 6TG

Sales Dept
Tel: 01884 257000 Fax: 01884 243500
E-mail: hepco.sales@hepco.co.uk

CATALOGUE No. DTS 04 UK © 2001 Hepco Slide Systems Ltd.

Reproduction in whole or part without prior authorisation from Hepco is prohibited. Although every effort has been made to ensure the accuracy of the information in this catalogue, Hepco cannot accept liability for any omissions or errors. Hepco reserves the right to make alterations to the product resulting from technical developments.

Many Hepco products are protected by: Patents, Copyright, Design Right or Registered Design. Infringement is strictly prohibited and may be challenged in law.

The Customer's attention is drawn to the following clause in Hepco's conditions of sale:

'It shall be the Customer's sole responsibility to ensure that goods supplied by Hepco will be suitable or fit for any particular application or purpose of the Customer, whether or not such application or purpose is known to Hepco. The Customer will be solely responsible for any errors in, or omissions from, any specifications or information the Customer provides. Hepco will not be obliged to verify whether any such specifications or information are correct or sufficient for any application or purpose.'

Hepco's full conditions of sale are available on request and will apply to all quotations and contracts for the supply of items detailed in this catalogue.



INVESTOR IN PEOPLE

