

NEW
CORROSION RESISTANT OPTION
AND BRAKE LOCKING DEVICE

HepcoMotion®

LBG Linear Ball Guides

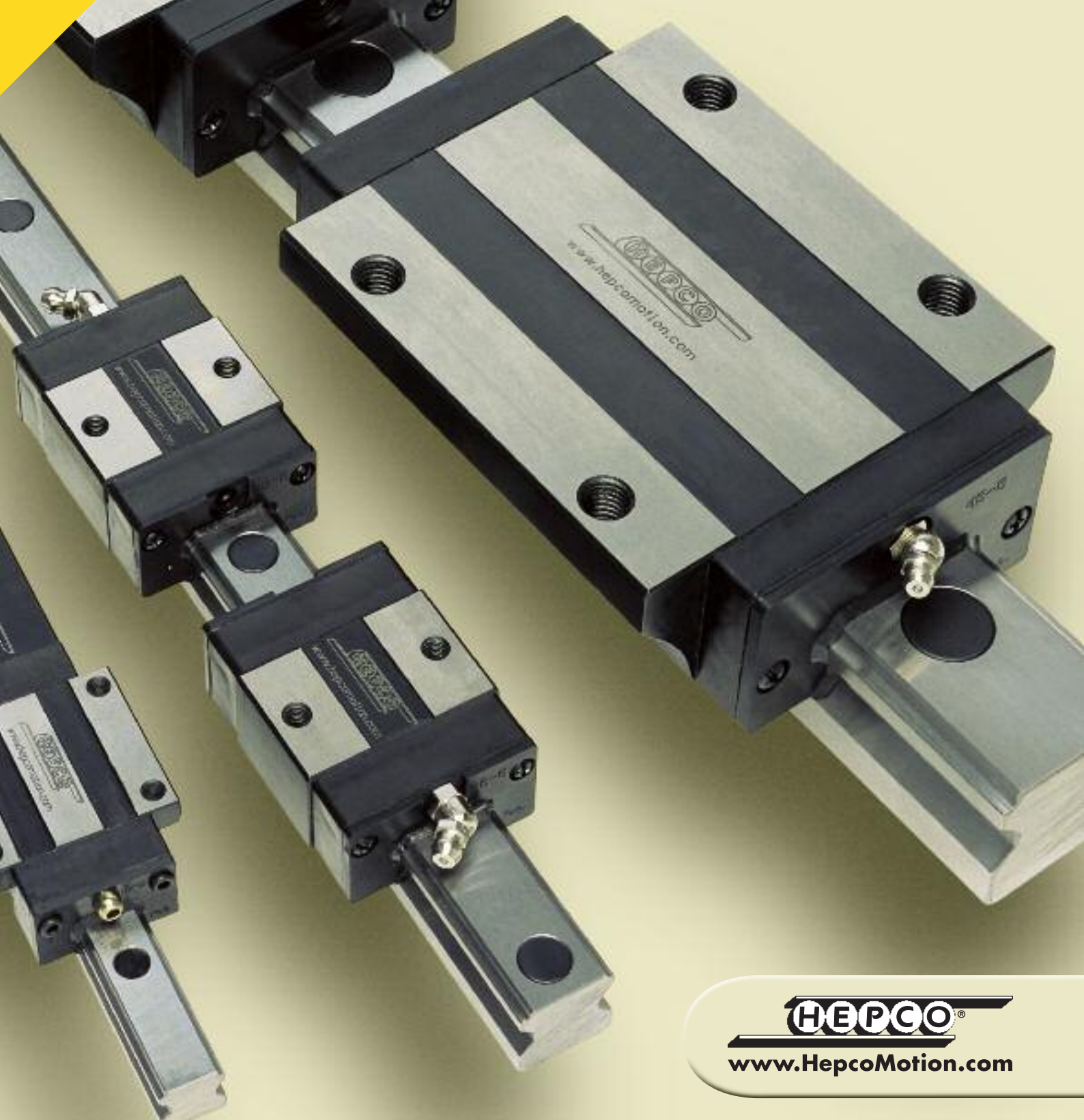

HEPCO®
www.HepcoMotion.com

Contents

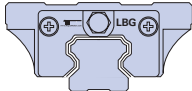
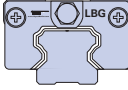
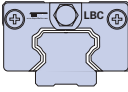
	Page
Introduction	1
Accuracy Details	2
Assembly Mounting – Preload	3
Selection Details	4
Product Dimensional Details	
LBG--F International Standard, with Flange	5
	
LBG--W International Standard, without Flange	6
	
LBC--W Compact, Long & Short Block, without Flange	7
	
LBG Brake Option	8
LBG Brake	9
Brake Plate - for LBG Blocks without flange	10
Brake Plates - for LBG Blocks with flange	11
Technical Data Load/Life	12-14
Ordering Details	15

Introducing the HepcoMotion® LBG Linear Ball Guides

Hepco's **LBG Linear Ball Guides** offer a comprehensive range of sizes, precisions and pre-load options designed to meet a broad range of applications where quality, accuracy, capacity, high reliability and interchangeability across international standard are considered prime requirements.

The **LBG** range has been designed and constructed around the Four Row Angular Contact ball track concept, thereby offering distinct user benefits such as low friction and reduced differential slip, higher loads, installation compliance and the ability to absorb minor errors on the mounting surfaces without compromising smooth movement and system performance (Figure 1).

In keeping with Hepco tradition the **LBG** range offers several unique design features setting it apart from other ball based linear guideways. The newly developed ball recirculating system has excellent performance characteristics resulting in – reduced friction, low noise and smooth movement. As with all bearing based recirculating systems it is important to ensure that the blocks are kept well lubricated during operation and regular lubrication intervals are observed.

The built-in Felt Wiper within the **LBG** block aids lubrication helping to maintain a positive oil film at the bearing contact surfaces (Figure 2).

The Hepco LBG range (Rails & Blocks) can be specified with a corrosion resistant treatment for added surface protection. Please contact Hepco's technical department for details.

Hepco LBG: Four Row Angular Contact Configuration

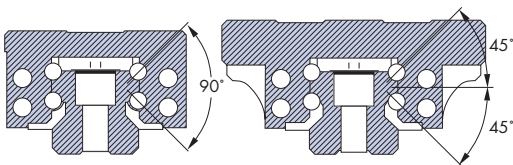

Figure 1

Bearing Block Configuration

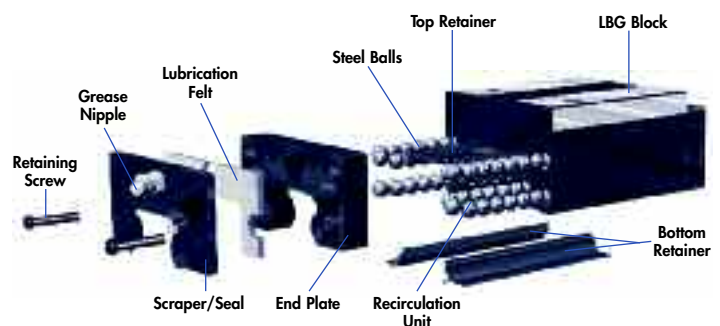
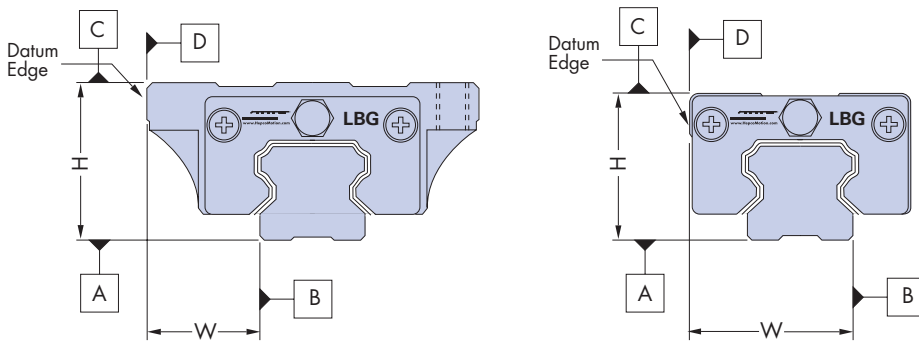

Figure 2

Hepco LBG – Features and Benefits

- Built-in Felt Wiper – Aids lubrication
- Angular Contact Configuration – Equal load carrying in four directions
- New Recirculation System – Smooth running/improved performance
- Range of Precisions – Satisfies a broad range of applications
- Integral All Round Sealing – Added protection
- Corrosion Resistant option - Surface protection
- High Accuracy – High levels of repeatability
- Interchangeable with International Standard
- Competitive prices – low installation costs
- Ex-Stock Delivery – Order with confidence

Accuracy Standard



Unit : mm

Item	Grade	Normal (N) see note	High (H)	Precision (P)	Super Precision (SP)	Ultra Precision (UP)
Tolerance on Height (H)		±0.1	±0.04	0 -0.04	0 -0.02	0 -0.01
Tolerance on Width (W)		±0.1	±0.04	0 -0.04	0 -0.02	0 -0.01
Difference on Heights (▲ H)		0.03	0.02	0.01	0.005	0.003
Difference on Widths (▲ W)		0.03	0.02	0.01	0.005	0.003
Running Parallelism of LB Block Surface C with respect to Surface A		▲ C Refer to Figure 1				
Running Parallelism of LB Block Surface D with respect to Surface B		▲ D Refer to Figure 1				

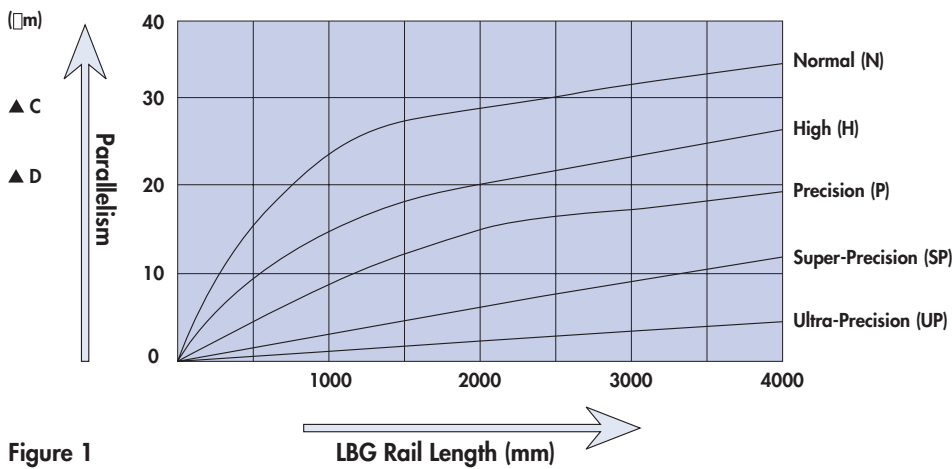
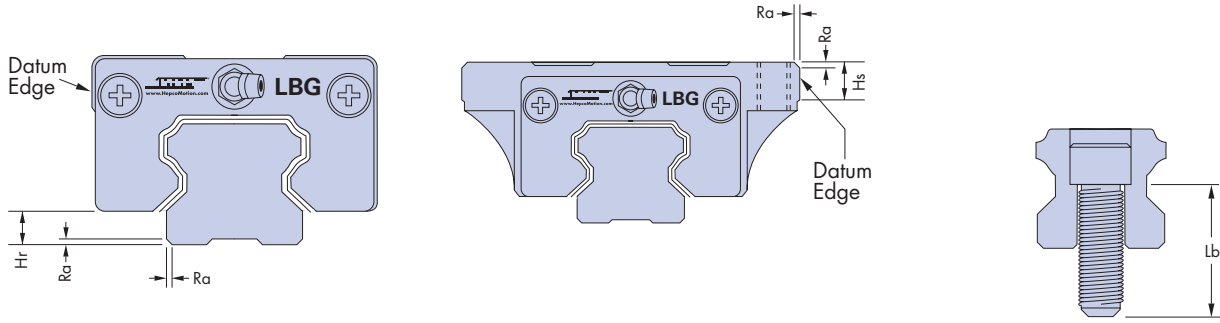

Figure 1

Assembly Details LBG



Unit : mm

Ref \ Item	(Ra) Max Fillet	(Hr) Max Height Rail Shoulder	(Hs) Max Height Block Shoulder	(Lb) Bolt Size/Length: Rail	Bolt Tightening Torque Unit : Nm	
					Steel Base	High Strength Aluminium Base
LBG - 15	0.8	4	5	M4 x 16	2.7	2.7
LBG - 20	0.8	4.5	6	M5 x 20	5.5	5.5
LBG - 25	1.2	6	7	M6 x 25	9.5	9.5
LBG - 30	1.2	8	8	M8 x 30	23	23
LBG - 35	1.2	8.5	9	M8 x 30	23	18
LBG - 45	1.6	12	11	M12 x 40	80	60
LBG - 55	1.6	13	12	M14 x 45	125	125

Mounting Surface Tolerance

1. Tolerance for Parallelism between two rails.

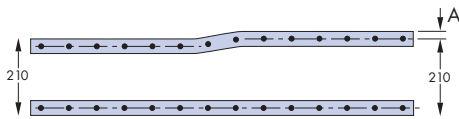

Unit : μm (A)

Grade \ Ref	Z3	Z2	Z1	Z0 see note	ZF
	LBG - 15	-	15	18	25
LBG - 20	-	18	20	25	25
LBG - 25	15	20	22	30	30
LBG - 30	20	27	30	40	40
LBG - 35	22	30	35	50	50
LBG - 45	25	35	40	60	60
LBG - 55	30	45	50	70	95

2. Tolerance for Mounting to a level surface.

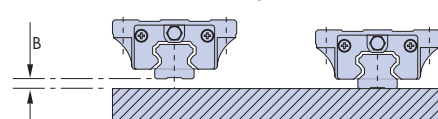

Unit : μm (B)

Grade \ Ref	Z3	Z2	Z1	Z0 see note	ZF
	LBG - 15	30	50	85	130
LBG - 20	30	50	85	130	130
LBG - 25	40	70	85	130	130
LBG - 30	50	90	110	170	170
LBG - 35	70	120	150	210	210
LBG - 45	80	140	170	250	250
LBG - 55	125	170	210	300	420

Preload Forces

Basic Dynamic Load Rating : C

Grade	Symbol	Preload Force
Clearance	ZF	0
Zero Preload	Z0	0
Light Preload	Z1	0.02C
Medium Preload	Z2	0.05C
Heavy Preload	Z3	0.07C

For further advice and assistance on mounting and assembly – please contact our Technical Department.

Selection Details LBG

Hepco's range of Linear Ball Guides are designed to interchange with international standards and come with a range of options to give the user choice in design and selection.

Hepco offer a full range of sizes with precisions and preloads to meet your particular application requirements. All the options listed are available on a short lead time basis. To enable Ex-stock delivery a selected range across the most popular sizes, in 'N' – Normal Precision and 'Z1' Light Preload, are held in stock, these are marked with the **Stock Range** symbol on the relevant pages.

As with all Hepco products a full selection and application advisory service is offered via our Technical Department – please contact our Sales Department for advice and assistance.

Accuracy Grades	
'N'	Normal Stock Range
'H'	High Grade
'P'	Precision Grade
'SP'	Super Precision
'UP'	Ultra Precision

See page 2 for accuracy details.

Preload Grades	
'ZF'	Clearance
'ZO'	Zero Preload
'Z1'	Light Preload Stock Range
'Z2'	Middle Preload
'Z3'	Heavy Preload

See page 3 for preload details.

Block/Flange Selection	
'F'	With Flange Stock Range
'W'	Without Flange Stock Range
'T'	Through Hole with Flange Ask for Details
'FL'	Long Type with Flange Stock Range
'WL'	Long Type without Flange Stock Range
'TL'	Long Type Through Hole with Flange Ask for Details
'WS'	Short Type without Flange Stock Range

See page 19 for part number configuration and full ordering details.

Linear Rail Options

PART No.	dxDxh
LBG – 15N	4.5x7.3x5.3
LBG – 20N	6x9.5x8.5
LBG – 25N	7x11x9
LBG – 30N	9x14x12
LBG – 35N	9x14x12
LBG – 45N	14x20x17

Mounting from above

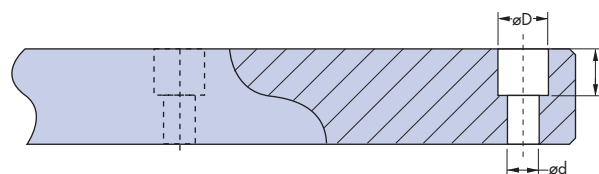

PART No.	MxL
LBG15N – K	M5x8
LBG20N – K	M6x10
LBG25N – K	M6x12
LBG30N – K	M8x15
LBG35N – K	M8x17
LBG45N – K	M12x24

Mounting from below

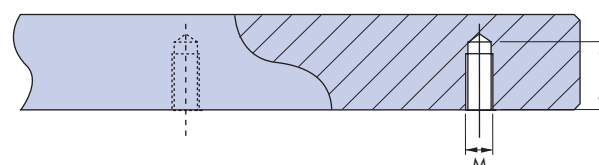

LBG--F International Standard – with Flange

'F' = Tapped Hole 'T' = Through Hole 'FL' = Long Type Tapped Hole 'TL' = Long Type Through Hole

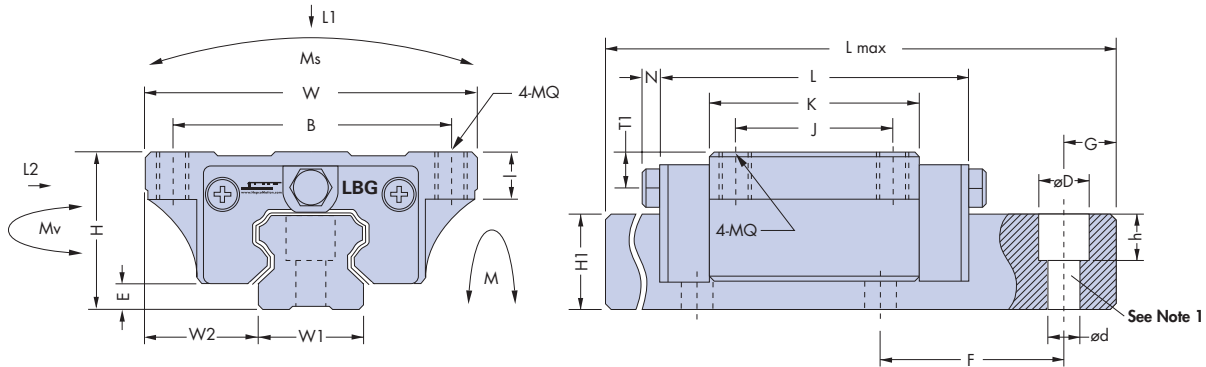

Customer to specify end hole position 'G'. If 'G' is not specified, dimensions will be equal both ends based on 'L' overall rail length.
Rail Options - Through Hole mounting from above (N) - Tapped Hole mounting from below (NK) please see page 4

Ref No.	System Assembly (mm)				LBG Block (mm)							LBG Rail (mm)			
	H	W	W2	E	L	BxJ	MQxl	K	Oil hole	T1	N	W1	H1	F	dxDxh
LBG - 15F	24	47	16	4.6	66	38x30	M5x8	40	∅3	4.3	5	15	14	60	4.5x7.3x5.3
LBG - 20F	30	63	21.5	5	77.8	53x40	M6x9	48.8	M6x1	5	6.5	20	18	60	6x9.5x8.5
LBG - 20FL					92.4			63.4							
LBG - 25F	36	70	23.5	7	88	57x45	M8x12	57	M6x1	5	6.5	23	22	60	7x11x9
LBG - 25FL					110.1			79.1							
LBG - 30F	42	90	31	9	109	72x52	M10x12	72	M6x1	7	6.5	28	26	80	9x14x12
LBG - 30FL					131.3			94.3							
LBG - 35F	48	100	33	9.5	119	82x62	M10x13	80	M6x1	8	6.5	34	29	80	9x14x12
LBG - 35FL					144.8			105.8							
LBG - 45F	60	120	37.5	14	148.2	100x80	M12x15	105	M8x1	10	13	45	38	105	14x20x17
LBG - 45FL					173			129.8							

Ref No.	Ref Data (mm)		Basic Load Rating (N)		Moment Load Rating (Nm)			Weight (Kg)	
	Lmax	G (min)	L1 Max	L2 Max	Ms Max	M Max	Mv Max	Block (Kg)	Rail Kg/m
LBG - 15F	4000	10	8500	8500	52	41	41	0.19	1.4
LBG - 20F	4000	10	14500	14500	125	102	102	0.4	2.6
LBG - 20FL			19000	19000	163	134	134	0.52	
LBG - 25F	4000	10	21400	21400	193	171	166	0.57	3.6
LBG - 25FL			29960	29960	270	240	232	0.72	
LBG - 30F	4000	12	29800	29800	326	271	266	1.1	5.2
LBG - 30FL			39000	39000	426	353	353	1.4	
LBG - 35F	4000	12	39600	39600	542	424	412	1.6	7.2
LBG - 35FL			52300	52300	705	536	536	2	
LBG - 45F	4000	16	67400	67400	1203	947	936	2.7	12.3
LBG - 45FL			83300	83300	1488	1170	1170	3.6	

Notes:

1. For screw size and torque details see assembly details page 3.
2. See page 15 for part number confirmation and ordering details.

Stock Range

LBG--W International Standard – without Flange

'W' = Without Flange

'WL' = Long Type without Flange

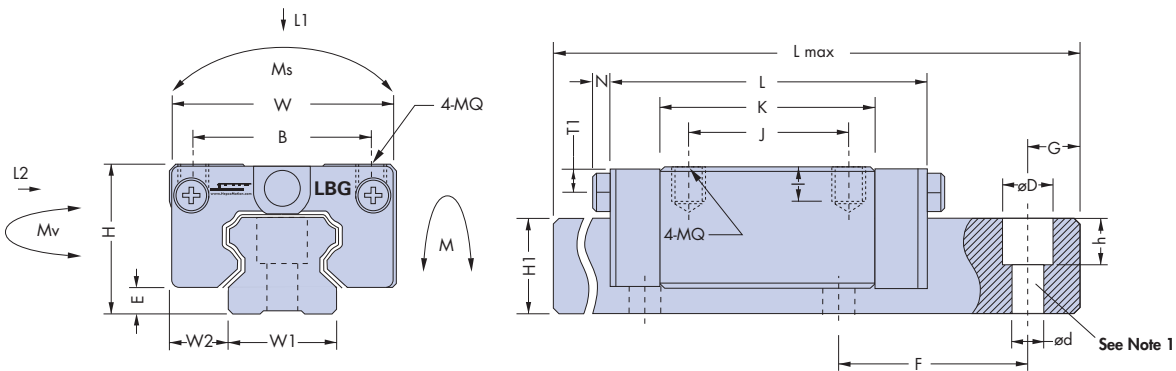

Customer to specify end hole position 'G'. If 'G' is not specified, dimensions will be equal both ends based on 'L' overall rail length.
 Rail Options - Through Hole mounting from above (N) - Tapped Hole mounting from below (NK) please see page 4

Ref No.	System Assembly (mm)				LBG Block (mm)							LBG Rail (mm)			
	H	W	W2	E	L	BxJ	MQxI	K	Oil hole	T1	N	W1	H1	F	dxDxh
LBG - 15W	28	34	9.5	4.6	66	26x26	M4x6.4	40	∅3	8.3	5	15	14	60	4.5x7.3x5.3
LBG - 20W	30	44	12	5	77.8	32x36	M5x8	48.8	M6x1	7	6.5	20	18	60	6x9.5x8.5
LBG - 20WL					92.4	32x50		63.4							
LBG - 25W	40	48	12.5	7	88	35x35	M6x9.6	57	M6x1	11.8	6.5	23	22	60	7x11x9
LBG - 25WL					110.1	35x50		79.1							
LBG - 30W	45	60	16	9	109	40x40	M8x12.8	72	M6x1	10	6.5	28	26	80	9x14x12
LBG - 30WL					131.3	40x60		94.3							
LBG - 35W	55	70	18	9.5	119	50x50	M8x12.8	80	M6x1	15	6.5	34	29	80	9x14x12
LBG - 35WL					144.8	50x72		105.8							
LBG - 45W	70	86	20.5	14	148.2	60x60	M10x16	105	M8x1	18	13	45	38	105	14x20x17
LBG - 45WL					173	60x80		129.8							

Ref No.	Ref Data (mm)		Basic Load Rating (N)		Moment Load Rating (Nm)			Weight (Kg)	
	Lmax	G	L1 Max	L2 Max	Ms Max	M Max	Mv Max	Block (Kg)	Rail Kg/m
LBG - 15W	4000	10	8500	8500	52	41	41	0.21	1.4
LBG - 20W	4000	10	14500	14500	125	102	102	0.31	2.6
LBG - 20WL			19000	19000	163	134	134	0.47	
LBG - 25W	4000	10	21400	21400	193	171	166	0.45	3.6
LBG - 25WL			29960	29960	270	240	232	0.56	
LBG - 30W	4000	12	29800	29800	326	271	266	0.91	5.2
LBG - 30WL			39000	39000	426	353	353	1.2	
LBG - 35W	4000	12	39600	39600	542	424	412	1.5	7.2
LBG - 35WL			52300	52300	705	536	536	1.9	
LBG - 45W	4000	16	67400	67400	1203	947	936	2.3	12.3
LBG - 45WL			83300	83300	1488	1170	1170	2.8	

Notes:

1. For screw size and torque details see assembly details page 3.
2. See page 15 for part number confirmation and ordering details.

Stock Range

LBC--W Compact Version – without Flange

'W' = Standard Block

'WS' = Short Block

'WL' = Long Block

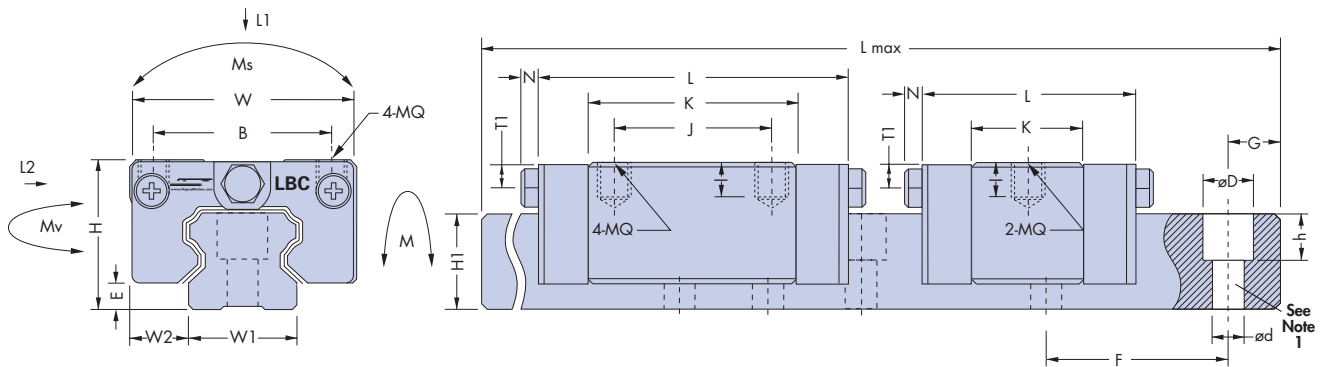

Customer to specify end hole position 'G'. If 'G' is not specified, dimensions will be equal both ends based on 'L' overall rail length.
 Rail Options - Through Hole mounting from above (N) - Tapped Hole mounting from below (NK) please see page 4

Ref No.	System Assembly (mm)				LBC Block (mm)							LBC Rail (mm)			
	H	W	W2	E	L	BxJ	MQxl	K	Oil hole	T1	N	W1	H1	F	dxDxh
LBC - 15W	24	34	9.5	4.6	66	26x26	M4x5.6	40	Ø3	4.3	5	15	14	60	4.5x7.3x5.3
LBC - 15WS					47.6	26x-		21.6							
LBC - 20W	28	42	11	5	77.8	32x32	M5x7	48.8	M6x1	5	6.5	20	18	60	6x9.5x8.5
LBC - 20WS					58	32x-		28							
LBC - 25W	33	48	12.5	7	88	35x35	M6x8.4	57	M6x1	4.8	6.5	23	22	60	7x11x9
LBC - 25WS					62.5	35x-		31.5							
LBC - 25WL					110.1	35x50		79.1							
LBC - 30W	42	60	16	9	109	40x40	M8x11.2	72	M6x1	7	6.5	28	26	80	9x14x12
LBC - 30WS					75.6	40x-		38.6							
LBC - 30WL					131.3	40x60		94.3							
LBC - 35W	48	70	18	9.5	119	50x50	M8x11.2	80	M6x1	8	6.5	34	29	80	9x14x12
LBC - 35WS					84.7	50x-		45.7							
LBC - 35WL					144.8	50x72		105.8							
LBC - 45W	60	86	20.5	14	148.2	60x60	M10x14	105	M8x1	8.5	13	45	38	105	14x20x17
LBC - 45WL					173	60x80		129.8							

Ref No.	Ref Data (mm)		Basic Load Rating (N)		Moment Load Rating (Nm)			Weight (Kg)	
	Lmax	G	L1 Max	L2 Max	Ms Max	M Max	Mv Max	Block (Kg)	Rail Kg/m
LBC - 15W	4000	10	8500	8500	52	41	41	0.17	1.4
LBC - 15WS			5100	5100	32	26	26	0.10	
LBC - 20W	4000	10	14500	14500	125	102	102	0.26	2.6
LBC - 20WS			8300	8300	71	58	58	0.17	
LBC - 25W	4000	10	21400	21400	193	171	166	0.38	3.6
LBC - 25WS			11900	11900	107	93	92	0.21	
LBC - 25WL			29960	29960	270	240	232	0.53	
LBC - 30W	4000	12	29800	29800	326	271	266	0.81	5.2
LBC - 30WS			15950	15950	174	146	146	0.48	
LBC - 30WL			39000	39000	426	353	353	1.06	
LBC - 35W	4000	12	39600	39600	542	424	412	1.2	7.2
LBC - 35WS			22600	22600	308	240	234	0.8	
LBC - 35WL			52300	52300	705	536	536	1.6	
LBC - 45W	4000	16	67400	67400	1203	947	936	2.1	12.3
LBC - 45WL			83300	83300	1488	1170	1170	2.6	

Notes:

- For screw size and torque details see assembly details page 3.
- See page 15 for part number confirmation and ordering details.

Stock Range

LBG Brake Option

The HepcoMotion® LBG Brake provides a compact, and simple method of locking an LBG Bearing Block in position. The brake is intended for manual locking of a stationary block, and can be supplied with a range of brake plates to suit most of the LBG bearing block options. When the brake is applied the resulting clamping force does not impose any load upon the bearing block.

Although tailored to suit Hepco LBG Linear Ball Guides, the brake is equally compatible with other ball guide systems, and is manufactured with all stainless steel components*1.

Dimensions for all sizes are contained on pages 9-11. For information on how to select an LBG brake or details on a specific application please contact Hepco's technical department.

For more information on LBG bearing blocks see the LBG linear ball guides catalogue.

Stainless Steel Brake Body

- 5 sizes available to suit the LBG rail.



Ratchet Locking Lever

- Allows for easy tightening.

Brake fitted to a compact block

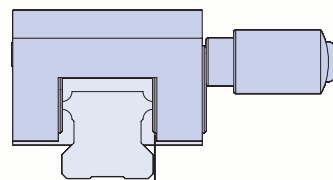

Brake fitted to a standard block

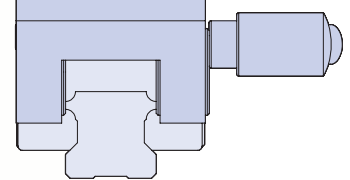

The height between the block and the rail will vary depending on the type of bearing block being used.

Brake Jaws

- The brake assembly has two stainless steel jaws which, when tightened via the ratchet locking lever, apply equal pressure to the LBG rail to ensure even clamping.

Brake Plate (Optional)

- Used to secure the brake to the LBG block.
- Available in a wide range of sizes.

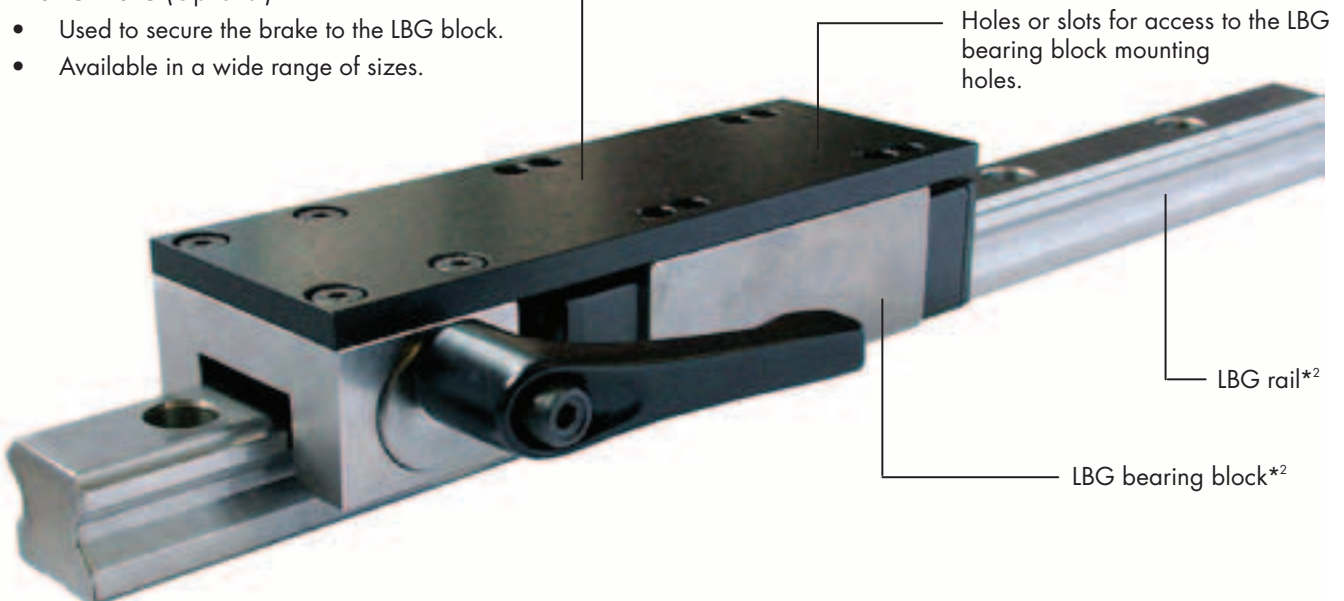

Holes or slots for access to the LBG bearing block mounting holes.

LBG rail*2

LBG bearing block*2

Note:

1. The ratchet locking lever of the LBG15B and LBG20B brakes contain a steel threaded insert and is not available in stainless steel.
2. Please note LBG block and rail are shown for clarity only, not included as part of the brake assembly.

LBG Brake

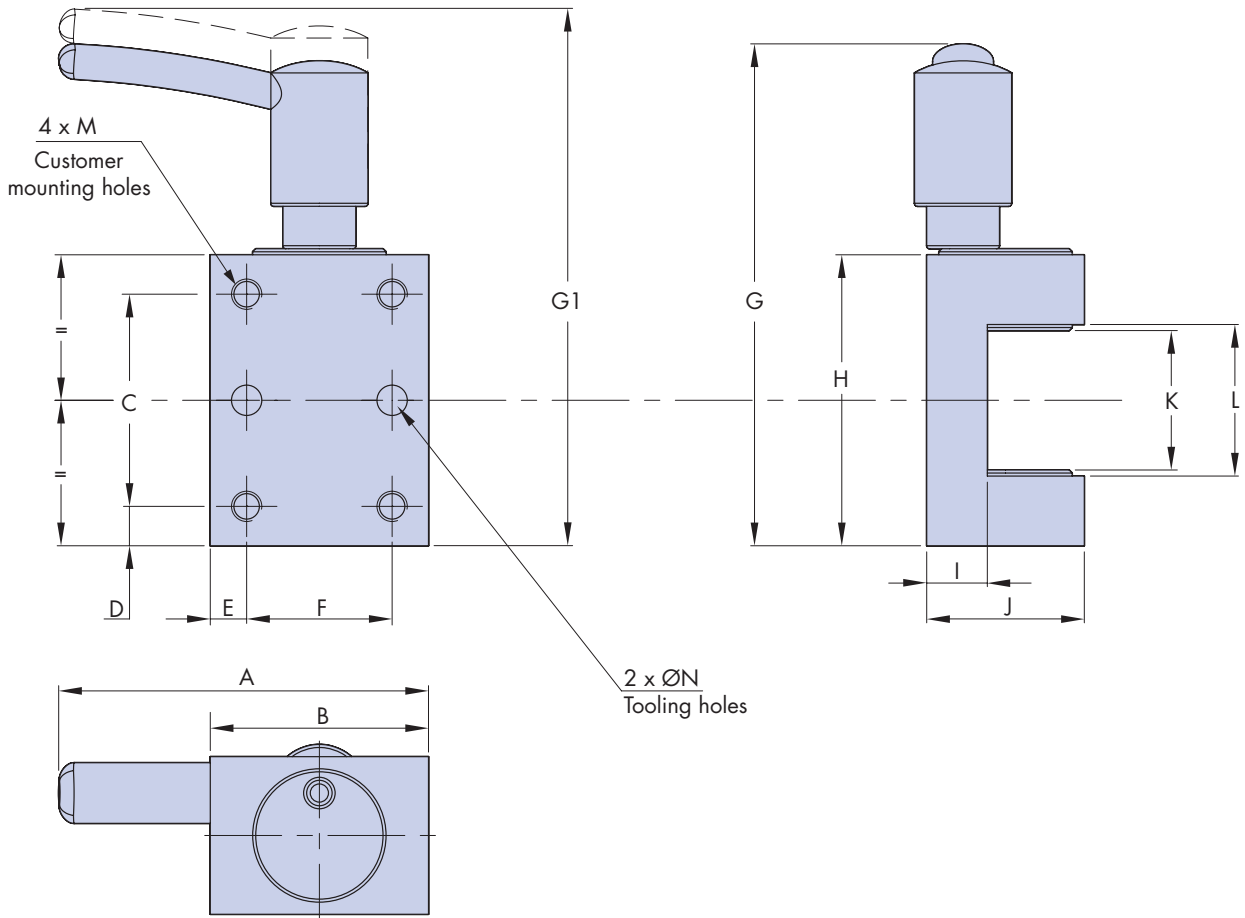

LBG Brake	For use with LBG Rail size	A	B	C	D	E	F	G ¹	G1 ²	H	I	J	Kmax ²	Kmin ¹	L	M	N
LBG15B	15	56	28	22	6	5	18	72	76	34	9	19.5	17	15	17	M4 x 5 Dp	Ø4 x 5 Dp
LBG20B	20	58	30	32	6	5	20	82	86	44	9	22	22	20	22	M4 x 5 Dp	Ø4 x 5 Dp
LBG25B	25	61	36	35	6.5	6	24	79	83	48	10	26	25	23	25	M5 x 6 Dp	Ø5 x 6 Dp
LBG30B	30	85	38	40	10	6.5	25	104	110	60	15	33	30	28	30	M6 x 8 Dp	Ø6 x 7 Dp
LBG35B	35	89	46	50	10	7	32	115	121	70	18	38.5	36	34	36	M6 x 8 Dp	Ø6 x 7 Dp
LBG45B	45	90	50	60	13	8	34	132	138	86	21	46	47	45	47	M6 x 8 Dp	Ø6 x 7 Dp

Ordering Details - Brake only

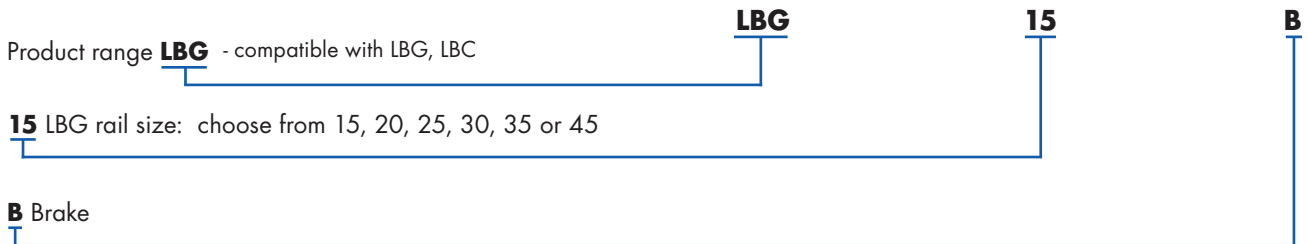

Notes:

- Dimensions G and Kmin are measured with the brake fully tightened against the rail.
- Dimensions G1 and Kmax are measured with the brake released and the handle in the disengaged position.

Brake Plate - for LBG Blocks without flange

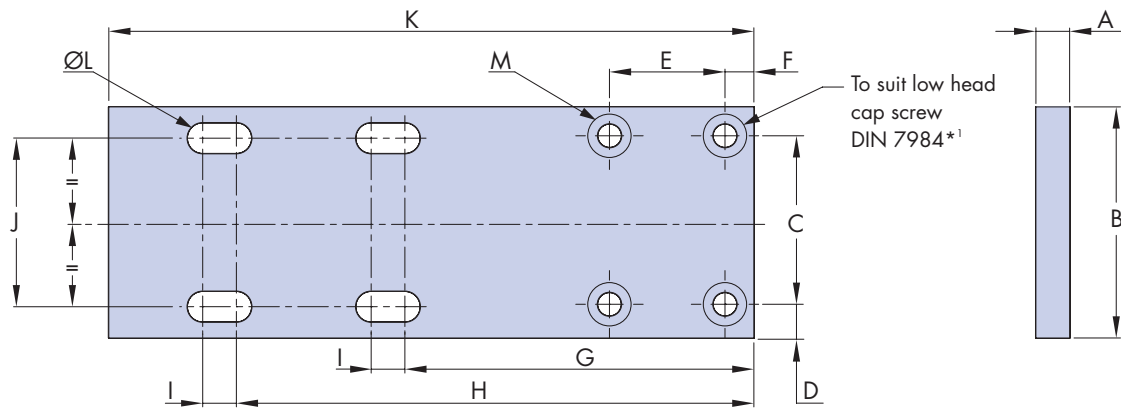

LBG Brake Plate	For use with LBG Block	A	B	C	D	E	F	G	H	I	J	K	ØL	M		
														C/Bore Ø	Depth	Hole Ø
LBG20BP1	LBG-20W LBC-20W	5	44	32	6	20	5	61	93	6.5	32	117	5.5	7.5	3	4.5
LBG25BP1	LBG-25W LBC-25W	7	48	35	7	24	6	72.5	107.5	7	35	134	6.5	9	3.8	5.5
LBG25BP2	LBG-25WL LBC-25WL	7	48	35	7	24	6	76	126	4.5	35	156	6.5	9	3.8	5.5
LBG30BP1	LBG-30W LBC-30W	8	60	40	10	25	6.5	82.5	122.5	3.5	40	157	8.5	10.5	4.3	6.5
LBG30BP2	LBG-30WL LBC-30WL	8	60	40	10	25	6.5	83.6	143.6	4.9	40	179	8.5	10.5	4.3	6.5
LBG35BP1	LBG-35W LBC-35W	8	70	50	10	32	7	90.5	140.5	6.5	50	175	8.5	10.5	4.3	6.5
LBG35BP2	LBG-35WL LBC-35WL	8	70	50	10	32	7	92.4	164.4	8.6	50	200	8.5	10.5	4.3	6.5
LBG45BP2	LBG-45WL LBC-45WL	8	86	60	13	34	8	106.5	186.5	5.5	60	233	10.5	10.5	4.3	6.5

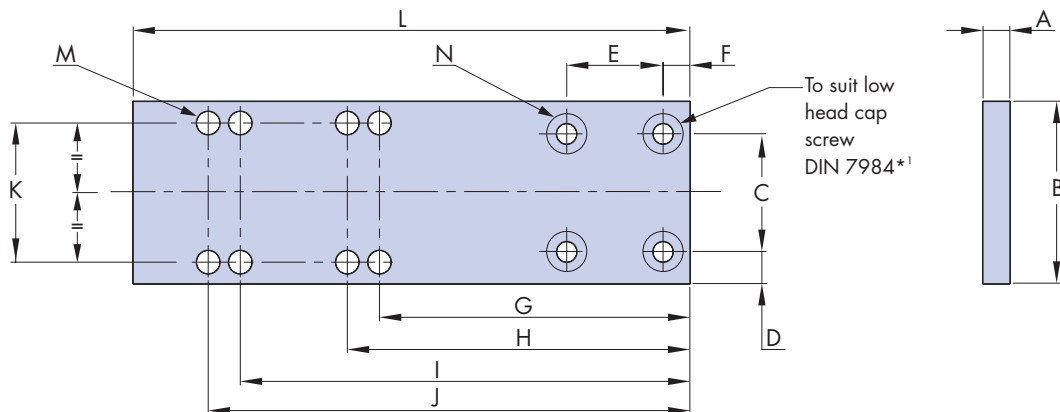

LBG Brake Plate	For use with LBG Block	A	B	C	D	E	F	G	H	I	J	K	L	M ²	N		
															C/Bore Ø	Depth	Hole Ø
LBG15BP1	LBG-15W LBC-15W	5	34	22	6	18	5	58	64	84	92	26	104	8 x Ø4.5	7.5	3	4.5
LBG15BP3	LBC-15WS	5	34	22	6	18	5	61.8	-	-	-	26	84	2 x Ø4.5	7.5	3	4.5
LBG20BP3	LBC-20WS	5	44	32	6	20	5	69	-	-	-	32	97	2 x Ø5.5	7.5	3	4.5
LBG20BP2	LBG-20WL	5	44	32	6	20	5	61.2	68	111.2	118	32	130	8 x Ø5.5	7.5	3	4.5
LBG25BP3	LBC-25WS	7	48	35	6.5	24	6	77.25	-	-	-	35	107	2 x Ø6.5	9	3.8	5.5
LBG30BP3	LBC-30WS	8	60	40	10	25.5	6.5	85.8	-	-	-	40	123	2 x Ø8.5	10.5	4.3	6.5
LBG35BP2	LBC-35WS	8	70	50	10	32	7	98.35	-	-	-	50	140	2 x Ø8.5	10.5	4.3	6.5
LBG45BP1	LBG-45W LBC-45W	8	86	60	13	34	8	104	164	-	-	60	208	4 x Ø10.5	10.5	4.3	6.5

Notes:

1. Low head cap screws to DIN 7984 are available from Hepco on request.
2. Not all brake plates will have eight holes due to the size of the block to which they fit. The number of holes each will have is as shown in column M.
3. Plates are fully machined from aluminium alloy and supplied black anodised.

Brake Plates - for LBG Blocks with flange

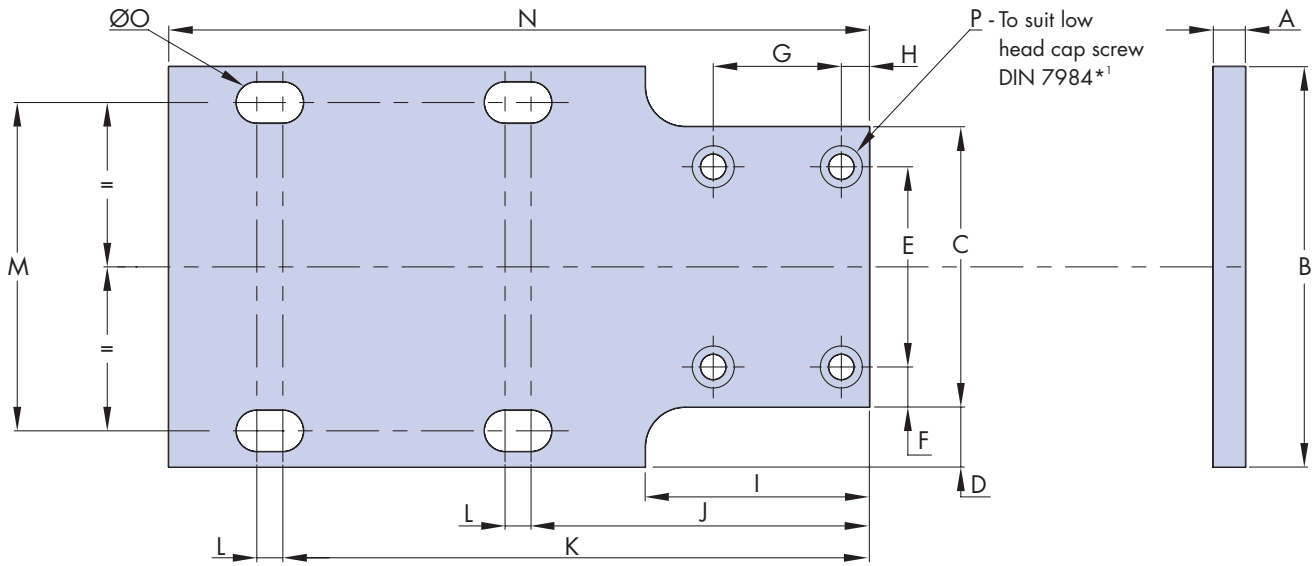

LBG Brake Plate*3	For use with LBG Block	A	B	C	D	E	F	G	H	I	J	K	L	M	N	ØO	P		
																	C/Bore Ø	Depth	Hole Ø
LBG15BP4	LBG-15F	5	47	34	6.5	22	6	18	5	38	56	86	6	38	104	5.5	7.5	3	4.5
LBG20BP4	LBG-20F	5	63	44	9.5	32	6	20	5	40	58.9	98.9	4.6	53	117	6.5	7.5	3	4.5
LBG20BP5	LBG-20FL	5	63	44	9.5	32	6	20	5	40	66.2	106.2	6.8	53	132	6.5	7.5	3	4.5
LBG25BP4	LBG-25F	7	70	48	11	35	7	24	6	46	67.5	112.5	7	57	134	8.5	9	3.8	5.5
LBG25BP5	LBG-25FL	7	70	48	11	35	7	24	6	46	78.5	123.5	4.5	57	156	8.5	9	3.8	5.5
LBG30BP4	LBG-30F	8	90	60	15	40	10	25	6.5	48	76.5	128.5	3.5	72	157	10.5	10.5	4.3	6.5
LBG30BP5	LBG-30FL	8	90	60	15	40	10	25	6.5	48	87.5	139.5	5	72	179	10.5	10.5	4.3	6.5
LBG35BP4	LBG-35F	8	100	70	15	50	10	32	7	56	84.5	146.5	6.5	82	175	10.5	10.5	4.3	6.5
LBG35BP5	LBG-35FL	8	100	70	15	50	10	32	7	56	97.4	159.4	8.6	82	200	10.5	10.5	4.3	6.5
LBG45BP4*2	LBG-45F	8	120	86	17	60	13	34	8	60	94.1	174.1	-	100	208	12.5	10.5	4.3	6.5
LBG45BP5	LBG-45FL	8	120	86	17	60	13	34	8	60	106.5	186.5	5.5	100	233	12.5	10.5	4.3	6.5

Notes:

1. Low head cap screws to DIN 7984 are available from Hepco on request.
2. This brake plate will have through holes instead of slots, in the positions as detailed above.
3. Plates are fully machined from aluminium alloy and supplied black anodised.

Ordering Details - Brake plate only

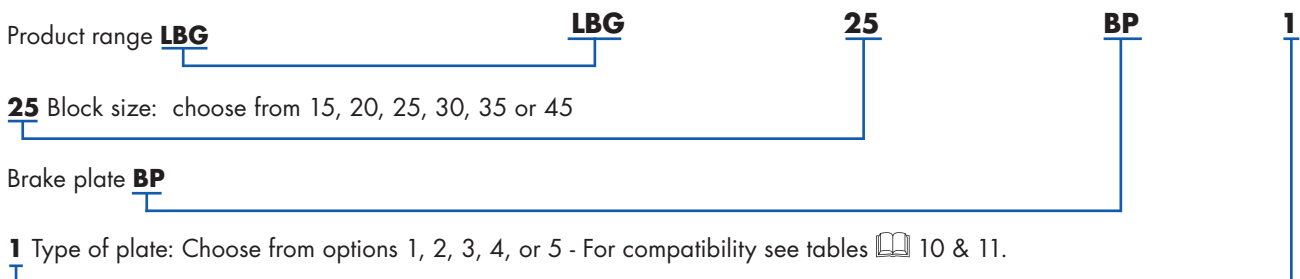

The LBG brake and brake plates are also available as a complete kit as shown at the bottom of 8. Please contact Hepco's technical department for more information.

Technical Data

Load/Life

Basic Static/Dynamic Load Rating Co & C

When a linear guide system is subjected to extreme load or impact, permanent deformation can occur between the raceway and rolling elements. Should deformation become excessive the running quality, smoothness and efficiency of the Guideway will be impaired.

The definition of basic load rating Co is stated as – a static load of constant magnitude acting in one direction under which the sum of the deformation of the elements and race way equals 0.0001 times the diameter of the rolling elements. Basic dynamic load rating C is the load of constant magnitude acting in one direction that results in nominal life of 50km for a Guideway using balls.

Basic Static Moment Rating Ms, M, Mv

The basic moment ratings in the Ms, M and Mv direction are stated as static moment capacities in the load rating charts (see pages 5-7).

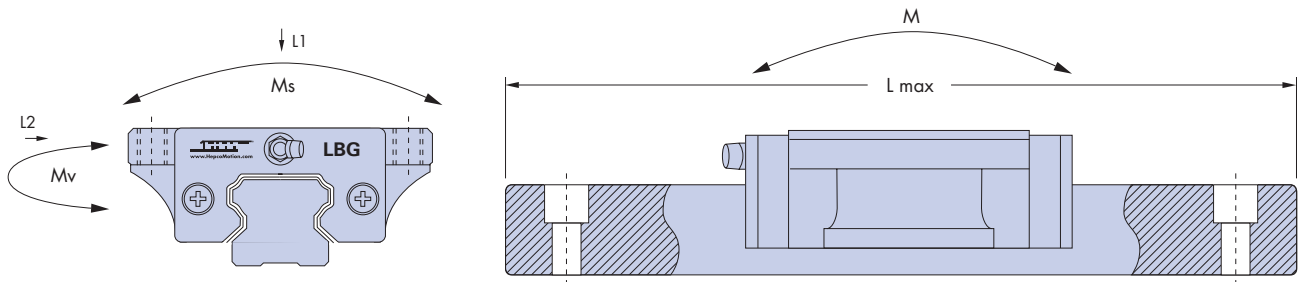

Safety Factor – Static : fa

The static safety factor fa should be considered related to the basic load rating Co, the acting load and the operating condition. Reference value of the static safety factor fa in given operating conditions is stated as follows:

Factor fa:

Operating Condition	Applied Load Condition	Minimum fa
Static	Small Impact	1.0 – 1.4
	High Impact Load	2.0 – 3.0
Dynamic	Small Impact	1.0 – 2.0
	High Impact Load	2.5 – 6.0

$$fa = (fb \times Co) / P \quad \text{or} \quad fa = (fb \times Mo) / M$$

- fa : Static Safety Factor
- Co : Basic Load Rating – Static
- P : Applied Load
- M : Applied Moment
- fb : Mounting Factor
- Mo : Permissible Static Moment

Technical Data

Mounting Factor : fb

In the Guideway mounting process, where the elements are in close contact it can be difficult to obtain a uniform distribution of the applied load across all the bearing blocks due to mounting face variations. Where two or more Blocks are used in close proximity or where there is a mounting surface variation – multiply the stated basic load ratings C and Co by the mounting factor.

Factor fb:

Blocks Per System	Mounting Factor fb
2	0.8
3	0.71
4	0.65
5	0.60
Normal	1

Frictional Resistance : μ

The frictional resistance of a Guideway can be determined using the following formula:

$$F = \mu \times P + fs$$

F : Frictional resistance (N) **P** : Load (N)

μ : Coefficient of friction **fs** : Seal resistance

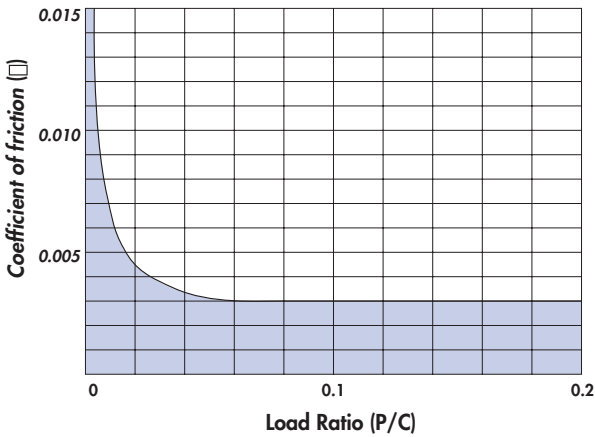

P : Load

C : Basic Dynamic Load Capacity

Seal Resistance : fs

Reference No.	Seal Resistance (N) per block
LBG – 15	2.6
LBG – 20	2.0
LBG – 25	3.6
LBG – 30	7.1
LBG – 35	8.2
LBG – 45	9.2

Variable Load Factor : fv

Impact and Vibration Condition	Travel Speed Velocity (V)	fv
No External Impact or Vibration	V ≤ 15m / min Low Speed	1 – 1.5
Slight Impact and Vibration	15 < V ≤ 60m / min Medium Speed	1.5 – 2.0
Medium Impact and Vibration	V > 60m / min High Speed	2.0 – 3.5

Technical Data

Raceway Hardness (HRC) : fr

Linear Guides operate at their optimum load carrying capacity with a raceway hardness of HRC 58 to 64. Where the raceway hardness is lower than HRC 58 the hardness factor fr should be applied. Hepco LBG Guides have a hardness value in excess of HRC 58, therefore a fr factor of 1.0 can be used.

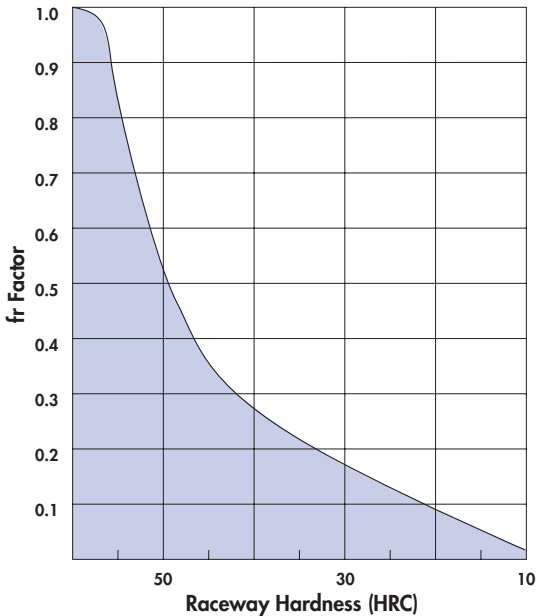

Guideway Temperature Factor : ft

Where Linear Guides are working in temperatures in excess of 100°C, a temperature factor ft should be used.

Note: Where the Guideway is subjected to temperatures greater than 80°C or less than -5°C please contact our Technical Department as consideration will have to be given to the seals, lubrication and end plates.

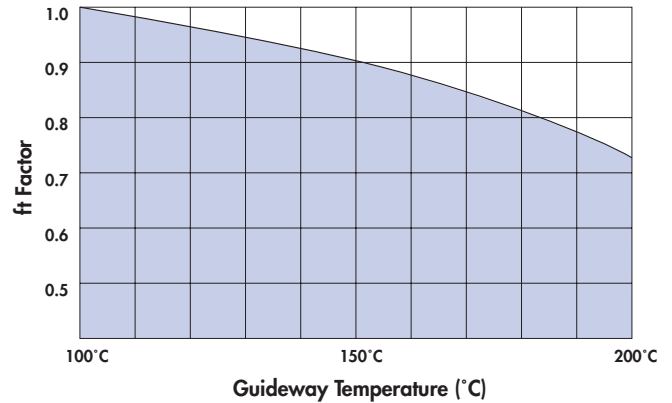

Nominal Life Formula : L

To calculate the life of a system using any of the LBG bearings, first obtain the Lf by entering the values for L1, L2, Ms, Mv and M in respect of the application, together with the maximum load capacities for the bearing from the relevant page, into the equation below.

$$L_f = \frac{L_1}{L_{1(Max)}} + \frac{L_2}{L_{2(Max)}} + \frac{M_s}{M_{s(Max)}} + \frac{M}{M_{(Max)}} + \frac{M_v}{M_{v(Max)}}$$

From the Lf figure the life of the system can be obtained from the calculation including factors fr, ft, fb and fv.

$$\text{Life (km)} = 50 \times \left(\frac{1 \times fr \times ft \times fb}{L_f \times fv} \right)^3$$

Ordering Details

Using the following part number configurator allows the correct specification of the LBG Guide Rail & Block to be ordered. Ordering details for the LBG Brake and Brake Plate can be seen on pages 9 and 11.

LBG Block

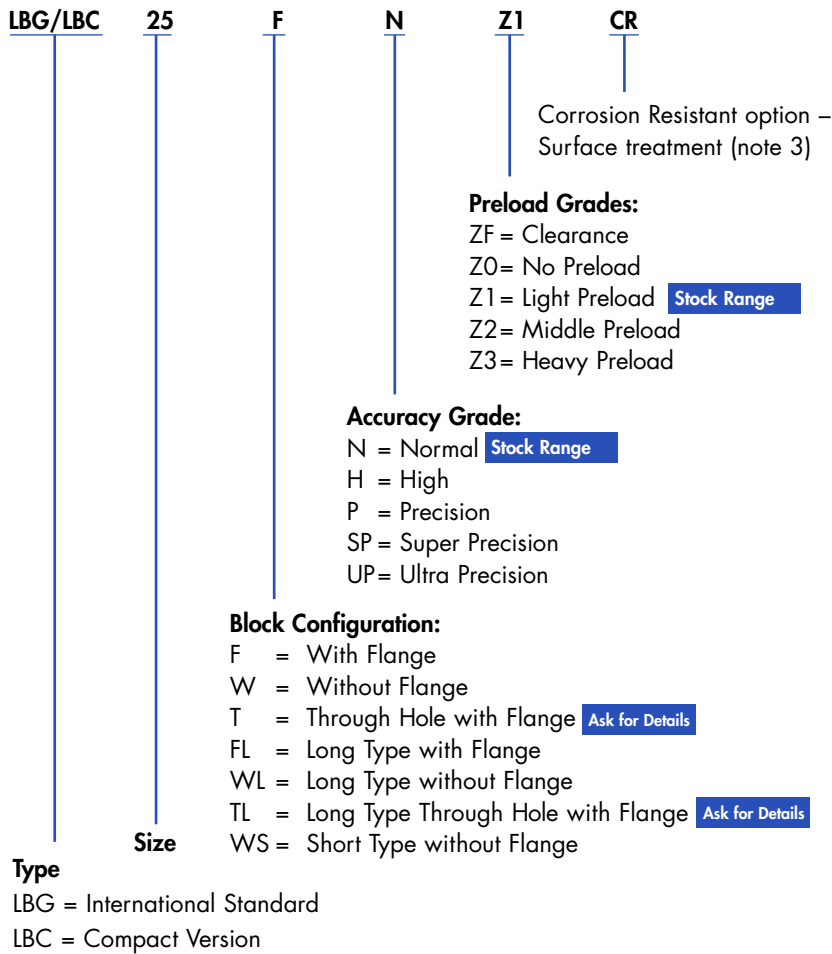

LBG Rail

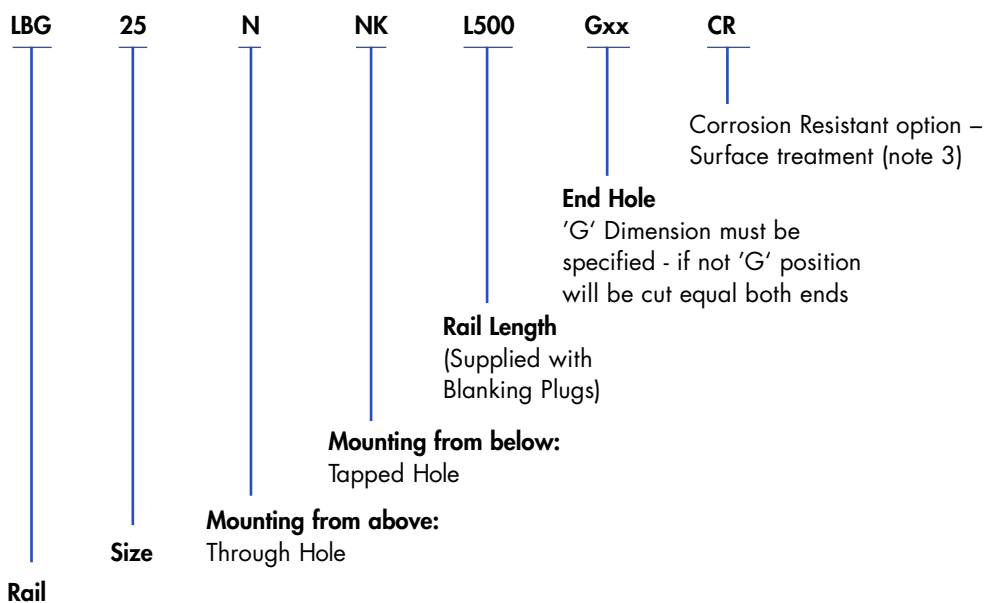

Notes:

1. Rail lengths greater than 4m can be achieved by butt joining. Please contact Hepco's Technical Department for details.
2. Rails & Blocks can be specified with corrosion resistant surface treatment. Please contact Hepco's Technical Department for details.
3. Please contact Hepco's technical department for details

HepcoMotion® Product Range



Bishop-Wisecarver Product Range

HepcoMotion® – Exclusive European partners and distributors for Bishop-Wisecarver since 1984.

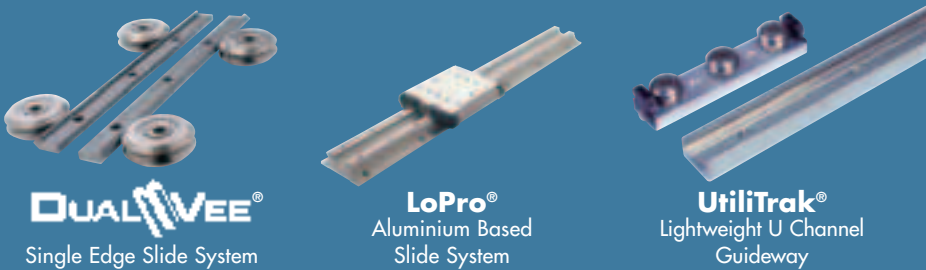

For further information on HepcoMotion® products – please request our leaflet 'FPL'



HepcoMotion®

Lower Moor Business Park, Tiverton Way, Tiverton, Devon, England EX16 6TG
Tel: +44 (0)1884 257000 Fax: +44 (0)1884 243500
E-mail: sales@hepcotion.com

CATALOGUE No. LBG 08 UK © 2011 Hepco Slide Systems Ltd.

Reproduction in whole or part without prior authorisation from Hepco is prohibited. Although every effort has been made to ensure the accuracy of the information in this catalogue, Hepco cannot accept liability for any omissions or errors. Hepco reserves the right to make alterations to the product resulting from technical developments.

Many Hepco products are protected by: Patents, Copyright, Design Right or Registered Design. Infringement is strictly prohibited and may be challenged in law. The Customer's attention is drawn to the following clause in Hepco's conditions of sale:

'It shall be the Customer's sole responsibility to ensure that goods supplied by Hepco will be suitable or fit for any particular application or purpose of the Customer, whether or not such application or purpose is known to Hepco. The Customer will be solely responsible for any errors in, or omissions from, any specifications or information the Customer provides. Hepco will not be obliged to verify whether any such specifications or information are correct or sufficient for any application or purpose.'

Hepco's full conditions of sale are available on request and will apply to all quotations and contracts for the supply of items detailed in this catalogue. HepcoMotion is the trading name of Hepco Slide Systems Ltd.

